

**PRASAR BHARATI  
BROADCASTING CORPORATION OF INDIA  
DIRECTORATE GENERAL: ALL INDIA RADIO  
(TELECOM DIVISION)**

**SPECIFICATION COVER SHEET**

TITLE : SPECIFICATION FOR MULTI CHANNEL  
STEREO DIGITAL MICROWAVE LINK

SPECIFICATION No. : TC/SPEC/11/105/STL (35 NUMBERS)

DATE OF LAST UPDATION : JUNE, 2010

NO. OF PAGES : 25

SCHEME : Upgradation of existing analog STL connectivity  
with Digital STL links at various AIR station.

**PRASAR BHARATI  
BROADCASTING CORPORATION OF INDIA  
DIRECTORATE GENERAL: ALL INDIA RADIO  
(TELECOM CELL)**

**Subject: Specification for the “Multi-Channel Stereo Digital Microwave Link”**

**1. INTRODUCTION**

AIR requires Multi-Channel Digital Microwave Links for transporting of programs from studio Centre to Transmitter locations where Studio and Transmitter are not Co-sited. These Microwave links are to be installed using towers (or structures on top of buildings having clear line of sight) at different locations. The scope of work includes the supply of the Multi-Channel Microwave links as per quantities given in the tender, Pre delivery inspection for acceptance, testing and installation of equipment and commissioning at all sites as per approved ATP.

The General specifications/requirements are detailed in Section ‘A’.

The technical specification/requirements are detailed in Section ‘B’.

The Draft ATP for Digital Microwave Link equipment is given in Section ‘C’.

A block diagram showing the Digital Microwave Link set up is enclosed as Annexure-A.



5	(1+1) UPS with individual separate Battery Back-Up and auto-change over switch.	Refer to Section.B-F	2 Set/Station (1 set at each end)
6	Stereo Wired Racks , Cables, Connectors and accessories	Refer to Section.B-G	2 Set/Station (1 set at each end)
7	5 Meters structure including civil works to support Dish Antenna & R.F cable on building roof top.		
8	Installation and Commissioning of complete link along with provision of proper Earth pits at both Studio and Transmitter end	Refer to Section. B-H	1 Job/Station
9	Training as per tender requirement: 2 Days Training on Operation & Maintenance at each Station.	Refer to Section A(5.3)	1 Job/Station
10	Inspection as per ATP	Refer to Section C	1 Job
11	Details of any other item required for complete integration, commissioning & operation may be furnished with the tender	-----	1 Lot /Station

**OPTIONAL ITEMS:**

Sl.no	ITEM	Specification	Quantity
1	Training as per tender requirement: 5 Days training on servicing at a central location.	Refer to Section A(5.3B)	1 Job

**2. QUANTITY:**

Total Quantity and configuration of Multi-Channel Digital Microwave Link at each of the Stations is given, station wise, in Annexure B.

**3. LOCATION FOR SUPPLY:**

Equipment is to be supplied at Studios and Transmitter locations at Stations mentioned in Annexure-B.

**4. SCOPE**

**4.1 Eligibility:**

a) The bidder shall have proven experience of carrying out SITC of Microwave Links. Bidders shall provide documentary proof (with attested copies of certificate from client including contact details like Telephone nos. and E-Mail address) of successfully carrying out at least one work of SITC of complete Microwave links/Broadcasting equipments(

Studio/Transmitter/earth station equipment) for an established and reputed organisations. Certificates issued by private individuals shall not be acceptable.

Bids without the above valid documents shall be liable for rejection without any further Communication.

**4.2** The scope of this tender includes supply of the equipment as per specifications, technical requirements and quantities as detailed in the tender, Pre-delivery inspection of the equipment, installation and commissioning of equipment at site and acceptance testing as per mutually accepted and approved Acceptance Test Procedure (ATP). Draft ATP is annexed.

**4.3** The equipment offered shall be of renowned make, well established and field proven. A list of clients with contact details, to whom the equipment has been supplied, must be enclosed. Any offer without the above list shall be liable to be rejected.

**4.4** The tenderer shall obtain all the technical requirements from indenter before installations. Minor changes at site, if any, necessitated due to site conditions shall have to be taken care of by the supplier during installation without any extra cost to the indenter.

**4.5** After Acceptance of the tender, the successful tenderer shall also provide detailed plans of supply of material, **installation link budget calculation sheet for each site**, testing and commissioning as per ATP.

**4.6 Inspection:**

**a) Pre-despatch Inspection:**

Pre-despatch Inspection of the links shall be carried out at Integrator's works by the Engineers(s) of All India Radio. The expenses towards to and fro journey, DA and lodging as per Govt. of India norms will be borne by Prasar Bharati. The performance certificate along with measurements taken on all equipments (duly certified by OEM) is required to be submitted by the tenderer before inspection at their premises.

During the Pre-dispatch inspection of whole equipment in one lot, supplier shall put up all the equipments for test on the test bench at integrator premises before the AIR representative and shall provide, without any extra charges, electric energy, consumable materials, tools, testing instruments, labour and assistance of every kind for carrying out acceptance tests. All the individual factory test reports of the complete lot of the equipment shall be made available to the inspecting authority before inspection. Inspection will be carried in one lot. Samples shall be drawn at random from the lot. Complete specifications and details for each equipment will be checked and all parameters/ values will be measured. Typical details are enclosed in draft ATP and inspection shall be carried out on these lines. Three weeks prior intimation for carrying out inspection at Works is to be given by the supplier to the indenter. Inspection charges, if any, are to be quoted separately in the commercial bid.

**b) Site Inspection:**

After completion of Installation of all the equipments at the Station, final inspection of the installation at the Station will be carried out by the representatives of AIR

for certifying the Installation. This inspection will include visual examination of the installation, overall performance measurements, link level measurements and any other measurement/ examination considered necessary by AIR. At least seven working days' prior notice shall be given by the supplier for conducting final Site Acceptance test.

## **5. GENERAL REQUIREMENTS**

### **5.1 Technical/General details**

The tenderer, in order to enable the indenter to carry out the full technical evaluation of the tender, should give all the details required to ascertain full merits and demerits of the technical offer.

**i)** The technical offer shall contain apart from the technical compliance statement, all original data sheets of the manufacturer in support of the technical compliance signed by OEM of that equipment alongwith his Tel. No. & name. The tenders containing only technical compliance statement without the original data sheet/ pamphlets of the equipment offered in full shall be liable to be rejected. The authorization to supply the equipment from the principals' is must if not quoted directly by the manufacturer, must be included.

**ii)** The tenderer may be asked to demonstrate the equipment to show compliance to AIR's specification at the technical evaluation stage. The tenderers shall furnish the list of the customers along with contact details (including Telephone Nos, E-Mail) where similar equipment has been supplied by the tenderer/manufacturers. In the absence of such list, tender may be rejected.

**iii)** This link equipment shall be of state-of-art technology, capable of working for 24 Hx365 days operation and link shall be able to work satisfactorily covering not less than 25 KM of air distance under city conditions.

**iv)** During the installation of these equipment supplier shall be responsible for safety and security of his material and personnel. At the same time the supplier shall also ensure that there is no damage to AIR material and personnel. Installation & Commissioning at respective stations shall be carried out without any disruption of AIR/Doordarshan Services. This may require installations at some sites to be carried out even during night hours for which adequate arrangements will have to be made by the supplier at no extra cost to the indenter.

**v)** The tenderer shall ensure that the equipment offered fully incorporate the standard features of safety and protection including shielding from EMI/RFI as the receive end of the Link will be installed at high power transmitter site.

**vi)** Provision of RF cable and associated materials as per site requirement shall be made. The rates of RF cables may be quoted on **per meter basis**. However, the offer will be ranked on the basis of a notional cable length of 100 meters each at both ends.

**vii)** Apart from printed technical data/specs of the equipment, Block schematic upto the sub-system, interconnection and wiring diagram, photograph etc. must also be attached with the offer.

**viii)** Successful bidder may conduct site survey at all the Stations, if felt necessary, to ascertain the conditions at Stations for facilitating installation of indoor equipments, hoisting of Dish antenna on the tower, routing of the cable, length of the RF cable, etc.

## **5.2 SPARES**

Tenderer should quote separately recommended essential spares including their quantities and cost (per unit). The cost of spares shall not be counted for deciding the commercial ranking of tenders. Various RF modules like transmitter, receiver, interface units, Audio Encoder-Decoder modules, Multiplexer-Demultiplexer modules, Power supply modules, etc must be quoted as spares along with other units.

## **5.3 Training**

A. The tenderer shall provide two days training to two AIR Engineers on operation and maintenance of the equipment at each Station. Training literature to two engineer/Station will be supplied. **This will be essential.**

B. In addition to above, 5 days training in each zone(Total five zones) for engineers ( 1 each from each station under zone, 1 from the Zonal office, 1 from STI(T) and two from Dte.) on servicing of equipment will be required to be arranged at manufacturer /supplier works in batches of not more than 15 persons and training literature for same will be supplied to each engineer. The expenses for to & fro journey and DA etc. for the trainees will be borne by AIR. **The cost of this training, if any, may be quoted separately as an optional item.** This shall not be counted for deciding the commercial ranking of tenders.

## **5.4 Compliance**

a) The compliance from **original equipment manufacturer** only will be considered. While complying to the specifications, it may be noted that just mentioning 'complied' will **NOT** suffice. Compliance should be supported by proper data/documentation and should substantiate the specifications. Each page of the datasheet/specification shall be duly signed, with seal, by both the OEM and tenderers. The full name, Postal and Telephone contact details including E-Mail address of the person signing on behalf of OEM must be indicated on at least one of the pages. Bids not complying with the above shall be rejected.

b) Deviations, if any, must be brought out clearly in the compliance statement. **Compliance Statements and Datasheets should concur with each other.** Proposals without the explicit compliance statement shall not be evaluated and would be rejected without any further communication to the bidder.

## **5.5 Schedule of Material:**

A comprehensive schedule of material offered shall be attached with the offer in the same format as mentioned in Section A as price bid minus the price. The price bid shall also be in the same format as the commercial bid. The tenders not complying this will be rejected. Price against each item as indicated in Section A-1( Bill of Material) shall be mentioned separately item wise. Any tender showing only the clubbed price for all the items or a group of items may be rejected.

#### **5.6 Maintenance support**

Maintenance support including availability of spares is to be ensured for at least 10 years from the date of supply. Details of the same should be mentioned in the tender.

#### **5.7 Documentation & Test Certificates:**

Following documents shall be supplied by the successful tenderer along with the equipment.

- a) **Manual:** [Two for each station, Two for directorate, one for each Zonal office, one for STI (T) and one for R&D]. Each manual shall consist of following-
  - i) Manual for complete link, operation system, as well as each sub-system and accessories (both hard & soft copies)
  - ii) Original manuals for installation and maintenance & servicing along with drawings and wiring diagram for the system.
- b) MTBF figures for all sub systems
- c) Test procedures for parameters measured at subsystem and integrated system levels.
- d) Test records/reports of all the measurements performed for each equipment.
- e) Compliance certificates
- f) Acceptance test reports & certificates for each equipment.

#### **5.8 Environmental & power supply**

- a) Ambient Temperature **(for outdoor units):**
  - 40°C to + 40°C – For Srinagar etc
  - 10°C to + 50°C –For other Stations
- b) Relative Humidity : Upto 95% non condensing at 40°C
- c) Safety/features : Standard features for safety & protection have to be built in /incorporated for both personnel/equipment.
- d) Power supply : 230VAC±10%, single phase, 48-52 Hz.

#### **5.9. Miscellaneous Clauses**

- i) The tenderer shall mention the source of supply (with proper authorization) and technical parameters for major and critical components/spares so that no difficulty is encountered later on in procuring the spares for maintenance/repair of these equipment.

- ii) If at any stage during next ten years the manufacturer proposes to stop production of these equipment and spares, supplier shall intimate AIR in advance to enable AIR to stock the critical items of spares for the life of the equipment.
- iii) **All the equipments shall carry a warranty for 12 Months from the date of acceptance of installation at site against any manufacturing defects and failures.**
- iv) All optional items mentioned in the tender must be quoted. Failing this, the tender would be liable to be rejected. However, these items would not be considered for ranking purpose.

**5.10** The tenderer/firm must have a well equipped & established service center in India. The complete address and contact details of the Service centers in India, duly certified by the OEM, shall be indicated. The firm/tenderer must ensure repairs within 72 hours at site & in case the equipment can not be repaired at site then the firm shall bear all the charges including to & fro freight charges to repair the equipment within or outside the country during the warranty period.

After sales service is to be ensured for post warranty period also.

**5.11 Delivery Period:**

The equipment shall be delivered in one lot and entire installation and commissioning shall be completed.

List of stations (priority wise) where equipment shall be supplied and installed in shall be intimated at the time of placement of purchase order.

## SECTION-B

### TECHINCAL SPECIFICATIONS FOR MULTI-CHANNEL DIGITAL STEREO MICROWAVE LINK

#### A. TRANS-RECEIVE EQUIPMENT

Trans-Receive equipment housed in a chassis should be supplied in 1+1 hot standby configuration. Transmitter section of this RF equipment should be capable of receiving E1 from the Audio baseband equipment and the receive section should be capable of retrieving the E1 data from the RF receiver and feed it into Audio equipment for facilitating demultiplexing of the Audio.

#### KEY FEATURES:

1. Full duplex operation.
2. Should be capable of delivering 31T slots of E1 data within 500 KHz channel bandwidth.
3. 19 inch rack mounting.
4. Each Trans-Receive unit should be capable of working independently in case of failure of Auto-Change over switch. All connectors and cables required for independent operation of standalone Trans-Receive unit shall be supplied.

#### i) **SYSTEM:**

1	a) Frequency of operation: b) Step Size: c) RF Frequency Stability: d)Tx-Rx Spacing:	1427-1525 MHz, Fully Synthesized, tunable Less than 1MHz. Better than 3 PPM. It should be possible to Transmit and Receive simultaneously frequencies spaced 49MHz apart
2	Modulation/Demodulation	32 QAM
3.	RF Bandwidth	≤ 500KHz
4.	Data Rates:	31T slots of E1
5	Interfaces: a) Data: b) Service Channel: c) Order wire:	G.703 RS232 @9600bps. Voice handset interface
6	Forward Error correction	Reed Solomon
7	WorkStation and Network Monitoring software from Original Equipment Manufacturer for Local and Remote Status & Control:	Refer Section B- Item E.
8	Diagnostics Function: Via Front panel display:	General Alarm of RF Power, BER etc.

9	(a) Configuration:  (b) Insertion loss for change over unit of (1+1) mode	(1+1) Hot standby with auto changeover. Also should work in 1+0 mode (Change over switch bypass mode) i.e. similar Antenna connector for TransReceive modem and changeover unit. Tx ≤ 2 dB Rx ≤ 5 dB
10	Power Supply	230 VAC ±10%, 50 Hz ±2 Hz
11	Standard Compliance:	ETS /EN international Standards for EMC/EMI and Radio Performance.
12	Size	19" Rack mount.

**ii) TRANSMITTER**

1.	RF O/P power at (1+0 mode)	≥ 30dBm at 50 ohm
2.	Spurious and Harmonics Emission	< - 60 dBc

**iii) RECEIVER**

1	Receiver Sensitivity (for 10 <sup>-6</sup> BER)	Better than -90 dBm
2	Dynamic Range	Better than 40 dB

**B. TECHNICAL SPECIFICATIONS OF AUDIO BASEBAND UNIT**

**I. Baseband Audio Encoder/ Decoder Modules with Mux/ Demux Card, Monitoring and Control card, power supply unit cards and accessories .**

The audio base-band Unit should be a separate unit & not an integral part of the RF equipment. The system should be offered as **(1+1)** chassis frame housing following Plug in cards at the Sending end and Receiving end.

**Sending End: (1+1) i.e. 2 chassis; each chassis containing following cards as per schematic Annexure 'A'**

- 1) Power Supply unit–(1+1) Redundant Power Supply
- 2) Audio Encoder cards (Quantity 3 at each Site)
- 3) Fractional E1 Mux card -one No.
- 4) Monitoring and Control card -one No.
- 5) Cable Connectors and Accessories

**Receiving End: (1+1) i.e. 2 chassis; each chassis containing following cards as per schematic Annexure 'A'**

- 1) Power Supply unit – (1+1) Redundant Power Supply
- 2) Audio Decoder cards (Quantity 3 at each Site)
- 3) Fractional E1 Demux card -1No.
- 4) Monitoring and Control card -1No.
- 5) Cable Connectors and Accessories.

Base band unit should fulfill the technical requirement of Endlink equipment by multiplexing/demultiplexing audio channels occupying bandwidth from 64kbps to 384 Kbps (in 64 kbps increments) and interface at the O/P with E1 circuits which are being provided by MTNL/ BSNL or Microwave link (Trans-Receive equipment (specified – Section B-Item A)). The unit should be ITU-T G.703 complaint.

Encoder and Mux cards are to be provided at Studio site and Decoder with Demux cards are to be provided at Transmitter site. The Encoder/Decoder modules must support both analog & digital input/outputs (user selectable through a switch /software). The system should be designed for continuous 24 Hours operation and should be software upgradable. The system should have capability for remote configuration, monitoring and control, Fault logging and alert through Network Management software from OEM using Laptop Workstation. Appropriate redundancy as described in following sections should also be provided in the system.

**(i) BASE BAND AUDIO ENCODER- DECODER MODULE:**

1.	Audio Input/output	Analog and Digital (AES/ EBU)(User selectable)
2.	Mode	Mono, Dual Mono, Stereo
3.	Configuration	Station wise details of audio channel configuration at Studio and Transmitter site is indicated at Annex-B.
4.	Frequency Response (20 Hz to 15 KHz)	$\pm 0.5$ dB w.r.t 1KHz at nominal level
5.	Audio input level (nominal at 1 KHz)	0dBu
6.	Audio input level (Max. at 1 KHz)	18 dBu above nominal
7.	Input Impedance (For Analog)	<b>600 <math>\Omega</math> Balanced / <math>\geq 10</math> K <math>\Omega</math> ( Selectable)</b>
8.	Audio output level (nominal at 1 KHz)	0dBu
9.	Audio output level (Max. at 1 KHz)	18 dBu above nominal
10.	Output Impedance ( For Analog)	<b>600 <math>\Omega</math> / <math>\leq 100</math> <math>\Omega</math> ( Selectable)</b>
11.	Input / Output Impedance ( For Digital)	110 $\Omega$
12.	Input / Output connectors	<b>XLR</b> In case the connectors on the encoder/decoder module are different from XLR, suitable adopters for terminating audio input/output on XLR connectors shall be provided and all XLR connectors shall be terminated on a back panel in the rack at no extra cost to the indenter.

13.	Coding Algorithm	MPEG 1 Layer II /APT -X
14.	A to D Conversion	24 Bit
15.	Sampling Frequency	48 KHz
16.	THD (1 KHz at max output level)	Less than 0.1%
17.	Cross talk	Better than 80 dB
18.	SNR	Better than 85 dB
19.	Data rate	Configurable 64, 128,192, 256,384 kbps per stereo channel
20.	Auxiliary Data channel	One, upto 9.6 kbps, Serial RS 232
21.	Mounting	19" Rack

**(ii) FRACTIONAL E1 MULTIPLEXER / DEMULTIPLEXER :**

This unit should fulfill the technical requirement of Endlink equipment by multiplexing/demultiplexing audio channels occupying bandwidth from 64kbps to 384 Kbps (in 64 kbps increments) and interface at the O/P with E1 circuits which are being provided by MTNL/ BSNL or Microwave link (Trans-Receive equipment (specified -Item A)). The unit should be ITU-T G.703 complaint. It should have Status LED's and test port for in-service maintenance. The system should have following specifications:

1.	Aggregate Throughput Rate	E1
2.	Data Rate:	Audio I/P: 64Kbps to 384Kbps in 64Kbps steps
3.	Interface	Should be able to connect directly to E1 trunks and also to G.703 Compliant Radio link equipment. Should conform to CCITT G.703.
4.	Jitter Tolerance	Shall Conform to CCITT Standard
5.	Configuration	Mux at Transmit end and Demux at Receive end

**(iii) MONITORING AND CONTROL**

1.	Remote access interface	Serial RS232 Asynchronous/ Ethernet 10Base-T
----	-------------------------	---

**C) ANTENNA (TRANSMIT/RECEIVE) ALONG WITH FEED & R.F. CABLE**

Antenna should be of reputed make and should be fully compatible with RF part of the link. All the parts of the antenna such as mounting fixtures etc. must be of same make and should be the part of the antenna kit from the same manufacturer. Antenna should be supplied with Deicing/Dome arrangements for installation at AIR Srinagar etc.

A 5M high GI Steel structure is required to be supplied and installed over the Roof top wherever no towers are present at the station and Antenna is required to be mounted over the roof top.

1.	Diameter (nominal)	≤ 2 M
2.	Gain (dBi) (midband)	≥ 26dBi
3.	Front to back ratio (dB)	≥ 30
4.	Polarization (mono-polar)	Linear adjustable(Vertical or Horizontal)
5.	Impedance	50 ohm (N.connector)
6.	Type	Grid pack/Flat panel/solid
7.	Weight(including mounting fixture and excluding De-icing system)	≤50 kg
8.	Azimuth adjustment (degree)	Min ±45 degree
9.	Elevation, adjustment (degree)	Min ± 5 degree
10.	Wind velocity (Survival)	180 Kmph
11.	VSWR	≤ 1.25
12.	R.F. cable loss at 1.5 Ghz	≤ 5 dB per 100 Meters
13.	R.F. cable impedance	50 Ohm
14.	<b>De Icing System/Dome (For AIR Srinagar etc) to operate on 230VAC±10% SINGLE Phase 48-52Hz.</b>	<b>Suitable De Icing system/Dome may be provided with Antenna so that system remains operational during and after snow fall.</b>

**D) WORK STATION FOR NETWORK MONITORING SOFTWARE (NMS):**

Reputed make Laptop/Notebook computer shall be provided individually at both Studio and Transmitter end. Laptop/Notebook computer shall be loaded with NMS from Original Equipment Manufacturer (OEM) for both R.F. Trans Receive equipment and Audio Base-band equipments as indicated in Bill of Material. The NMS should be capable of monitoring the status, controlling and setting operational parameters of R.F. Trans Receive equipment , Audio Base-band equipments and UPS. NMS should be also capable of configuring and monitoring receive side RF and Baseband equipment from transmit side itself and Vice versa. Any hardware keys (dongle), if required, for operation of NMS shall be supplied at each end. The laptop should have

**Operating System:** Pre loaded Genuine licensed Windows Vista(TM). Recovery CD media including all drivers etc. Fully loaded configuration. License in the name of consignee.

**E) NMS features:-**

The integrated NMS of all equipments (with license) must be using the industry standards SNMP as the underlying framework for managing network devices, providing a simple, intuitive suite of tools to configure network elements, monitor performance, detect and correct faults quickly of local as well as of remote units of RF Trasreceiver, Baseband unit and UPS.

- Network diagnostics for MW Link
- Proactive alarm/fault notification
- Remote network configuration
- Based on industry standard SNMP easy to integrate
- Graphical and Tabular displays-simple to use
- Embedded firmware reprogramming
- Event log upload and viewer

**F) DUAL UPS (Rack Mount Version):**

Two Nos of 2KVA Rack Mountable online single phase UPS, with 30 minutes full load battery backup, sealed maintenance free batteries shall be supplied in (1+1) configuration one each at Studio and Transmitter end. They should work in load sharing mode. The UPS should have NMS features for control and status monitoring.

**G. WIRED RACKS FOR EQUIPMENT**

All the above indoor equipment including work station shall be installed in the full size, 16 SWG wired rack of height 42U and overall depth of not more than 800 mm along with requisite jack- strip, Tag block & other items both at transmitting and receiving site.

Audio distribution Amplifier (Analog & Digital) inputs and outputs shall be wired. It is to feed Audio to input of normal and standby Encoder and to the switcher of monitoring Amplifier input at studio site .At transmitter site monitoring amplifier input is to be wired from decoders output through Distribution Amplifier as detailed in block diagram. All channels input at studio site and output at transmitter site are required to be wired as per Annexure ' A.'

The rack must be properly fitted, grouted and earthed. The rack shall be powder coated as per six tank process with air ventilation. It shall be fitted with cooling fan, light, power distribution board with proper RFI and EMI fitters. The jack strip, Tag block, cables and connectors used must be of highest professional quality. All these items shall be of reputed brand. The brand offered shall be mentioned in the bid (Ordinary cables and connectors shall not be accepted).

Typical stereo Patch panel configuration for a 3+3 audio channel configuration system is shown at Annexure-'C'. For other audio channel configurations similar wiring has to be adopted.

Successful tenderer will be required to submit detailed rack wiring diagram within 15 days of placement of order, to this Directorate for approval.

**H. INSTALLATION & COMMISSIONING**

Installation will include all the equipments within the wired racks, hoisting of the dish antenna over the towers or the roof top steel structure, routing of

the RF cable from the antenna to indoor system and providing earth pits as per AIR Specifications (earth resistance of less than one ohm) at both the Studio and Transmitter end at each of the Station. Racks and all the equipment must be earthed. The workmanship of the entire Installations shall be of high professional standard.

The firm shall have to arrange all the installation material required for installation and insure all the personnel climbing the towers at their own cost. Any fixtures, clamps or mounting accessories needed for hoisting the dish on the tower has to be arranged by the firm. Installation schedule at Stations has to be intimated at least 3 weeks in advance.

Complete Installation at each station shall thereafter be offered for Site Acceptance Test and Inspection at site shall be conducted by the representatives of DG: AIR.

The successful tenderer shall make good all damages to the purchaser's buildings, property, equipment, article and departmental personnel arising from the erection of the tower and/or mounting of antenna on tower, during the course of such erection or mounting and throughout the guarantee period.

The successful tenderer shall indemnify and hold harmless the purchaser, against all claims in respect of damages to buildings, property, articles, situated nearby not belonging to the purchaser, and public personnel arising from the erection of the tower and/or mounting of antenna on tower during the course of such erection or mounting and throughout the guarantee period.

The successful tenderer shall indemnify and hold harmless the purchaser against claims in respect of injury to any personal howsoever arising from the erection of the tower and/or mounting of antenna on tower in the course of such erection or mounting and throughout the guarantee period.

The successful tenderer shall fully discharge all obligations under the Indian Workmen's Compensation Act in so far as it affects the workmen under his employment.

The tenderer shall be responsible for safe erection of the tower and other accessories etc. The tenderer shall take all necessary safety measures and precautions during the SITC of tower. Tower work shall be got done at site under the supervision of qualified representative of the firm.

## SECTION C

### DRAFT ATP FOR DIGITAL MICROWAVE LINK

#### 1. INTRODUCTION

This document describes the Acceptance Test Procedure (ATP) for testing the various units of the Digital Microwave Link Equipment under procurement. It covers the details of the item to be tested, list of equipment required for testing and the tests required to be carried out.

#### 2. ITEMS TO BE TESTED

The items to be tested first individually and then integrated are as follows:-

##### a) Individual Items

- i) R.F. Tran receive Equipment
- ii) Base Band Unit
- iii) Other peripheral equipment such as Computer & UPS etc.
- iv) NMS

##### b) Integrated Setup

Complete integrated setup from Audio input to base-band unit to audio output from base band unit

#### 3. TEST EQUIPMENT

- a) All requisite test equipment conforming to the required standard for testing and commissioning shall have to be provided by the supplier.
- b) Indicative List of the test & measuring equipment:
  - i) Spectrum Analyzer (>2 GHz range)
  - ii) Power Meter with sensor & Attenuator etc.
  - iii) Frequency counter
  - iv) Signal Generator
  - v) Audio Analyzer
  - vi) BER Tester
  - vii) Digital Modulation Analyzer having Digital demodulation feature.
  - viii) PC with Printer
  - ix) Directional Coupler, inter-connecting cables, attenuators, combiners, Dividers, etc. as may be necessary for the tests.
  - x) Any other equipment and standard reference source/setup necessary for measurements.

#### **4. TESTS REQUIRED TO BE CARRIED**

(NOTE: This is only a tentative list, additional items of tests may be specified by the indenter, if needed.).

##### **4.1 RF TRANS-RECIEVER**

- i) Functionality test for individual RF Trans-Receiver and in (1+1) configuration
- ii) Power output check
- iii) Frequency stability and accuracy
- iv) Spurious & Harmonics
- v) DATA rate & coding standards
- vi) Digital modulation
- vii) Any other tests to check the conformity to the specs.

##### **4.2 Audio Base band Unit**

- a) Functionality test for individual Base-Band unit
- b) Coding standard, data rates check
- c) All Base-band measurements i.e. Frequency response, THD Noise level, Cross talk etc. as mentioned in ATP.

##### **4.3 RECEIVER**

- ii) Functionality check for individual monitoring setups for Analog signal and Digital signal
- iii) Tests for Analog output receiver including sensitivity, carrier lock range, audio output level: THD, Noise level, frequency response, cross talk etc.
- iv) Test for Digital O/P receiver including, carrier lock range, BER, Eb/No, Audio output, level, THD, Noise Level, frequency response, cross talk for both stereo channels, BER immunity test etc.

##### **4.4 INTEGRATED SETUP**

- i) After the individual tests the equipment will be installed and integrated to Work as MW link as per specs. The integrated setup will then be tested for complete system performance and functions.
- ii) The tests for commissioning would include the integration check and conformity to system specs including.
  - a. EIRP
  - b. Radiation conformity to standard specified
  - c. Emissions conforming to international standard. Overall Performance measurements to meet the specs.
  - d. Cable Loss(both at Transmitting & Receiving end)
  - e. Alignment of dish for optimum performance

#### **4.5 PERIPHERAL EQUIPMENT**

All peripheral equipment shall be tested for the various functionality prescribed and conformity with these specifications.

**4.6** In addition all the manuals/drawings will be inspected for completeness.

#### **5. GENERAL**

i) Based on above supplier is required to give a detailed ATP document giving procedure for tests of individual item as well integrated setup. This should include test setup, equipment details, inter-connection diagram and the format for test reports.

ii) The indenter will examine the same and then it will be finalized after mutual discussion.

## Annexure-B

### LIST OF STATIONS WHERE STUDIO TO TRANSMITTER CONNECTIVITY IS NEEDED TO BE UPGRADED/DIGITALIZED UNDER XI PLAN

#### NORTH EAST ZONE

Sr.no	State/station	FROM	TO
1.	<b>NAGALAND</b> KOHIMA	STUDIO	TX
2.	<b>TRIPURA</b> KAILASHAR	STUDIO	TX
3.	<b>MEGHALAYA</b> SHILLONG	STUDIO	FM TX

#### EAST ZONE

Sr.no	State/station	FROM	TO
1.	<b>WEST BENGAL</b> SILIGURI	STUDIO	TX
2.	<b>BIHAR</b> PATNA	STUDIO	HPT
3.	BHAGALPUR	STUDIO	FM TX

#### SOUTH ZONE

Sr.no	State/station	FROM	TO
1.	<b>TAMILNADU</b> COIMBATORE	STUDIO	FM TX
2.	TUTICORIN	STUDIO	TX
3.	<b>ANDHRA PRADESH</b> ANANTPUR	STUDIO	TX
4.	<b>KERALA</b> THIRUVANTPURAM	STUDIO	FM TX
5.	TIRUPATI	STUDIO	REPEATER(DOT TOWER)
6.	TIRUPATI	REPEATER	FM TX
7.	VISHAKAPATNAM	STUDIO	TX
8.	PORTBLAIR	STUDIO	TX
9.	PONDICHERY	STUDIO	TX

**WEST ZONE**

<b>Sr.no</b>	<b>State/station</b>	<b>FROM</b>	<b>TO</b>
1.	<b>MAHARASHTRA</b> PARBHANI	STUDIO	TX
2.	RATNAGIRI	STUDIO	TX
3.	SANGLI	STUDIO	TX
4.	SATARA	STUDIO	TX
5.	<b>GUJRAT</b> RAJKOT	STUDIO	TX
6.	<b>MADHYA PRADESH</b> AMBIKAPUR	STUDIO	TX
7.	RAIPUR	STUDIO	TX
8.	REWA	STUDIO	TX
9.	GUNA	STUDIO	TX
10.	GWALIOR	STUDIO	MW TX
11.	GWALIOR	STUDIO	FM TX

**NORTH ZONE**

<b>Sr.no</b>	<b>State/station</b>	<b>FROM</b>	<b>TO</b>
1.	<b>JAMMU &amp; KASHMIR</b> SRINAGAR	STUDIO	FM TX
2.	<b>RAJASTHAN</b> JODHPUR	FM TX	MW TX
3.	SURATGARH	STUDIO	TX
4.	NAGPUR	STUDIO	TX
5.	BIKANER	STUDIO	TX
6.	<b>HIMACHAL PRADESH</b> SHIMLA	STUDIO	TV SITE (REPEATER)
7.	<b>U.P</b> RAMPUR	STUDIO	TX
8.	NAJIBABAD	STUDIO	TX
9.	VARANASI	STUDIO	TX

**REPRESENTATIVE DIAGRAM FOR STL AT STUDIO END FOR 1+1 CONFIGURATION**

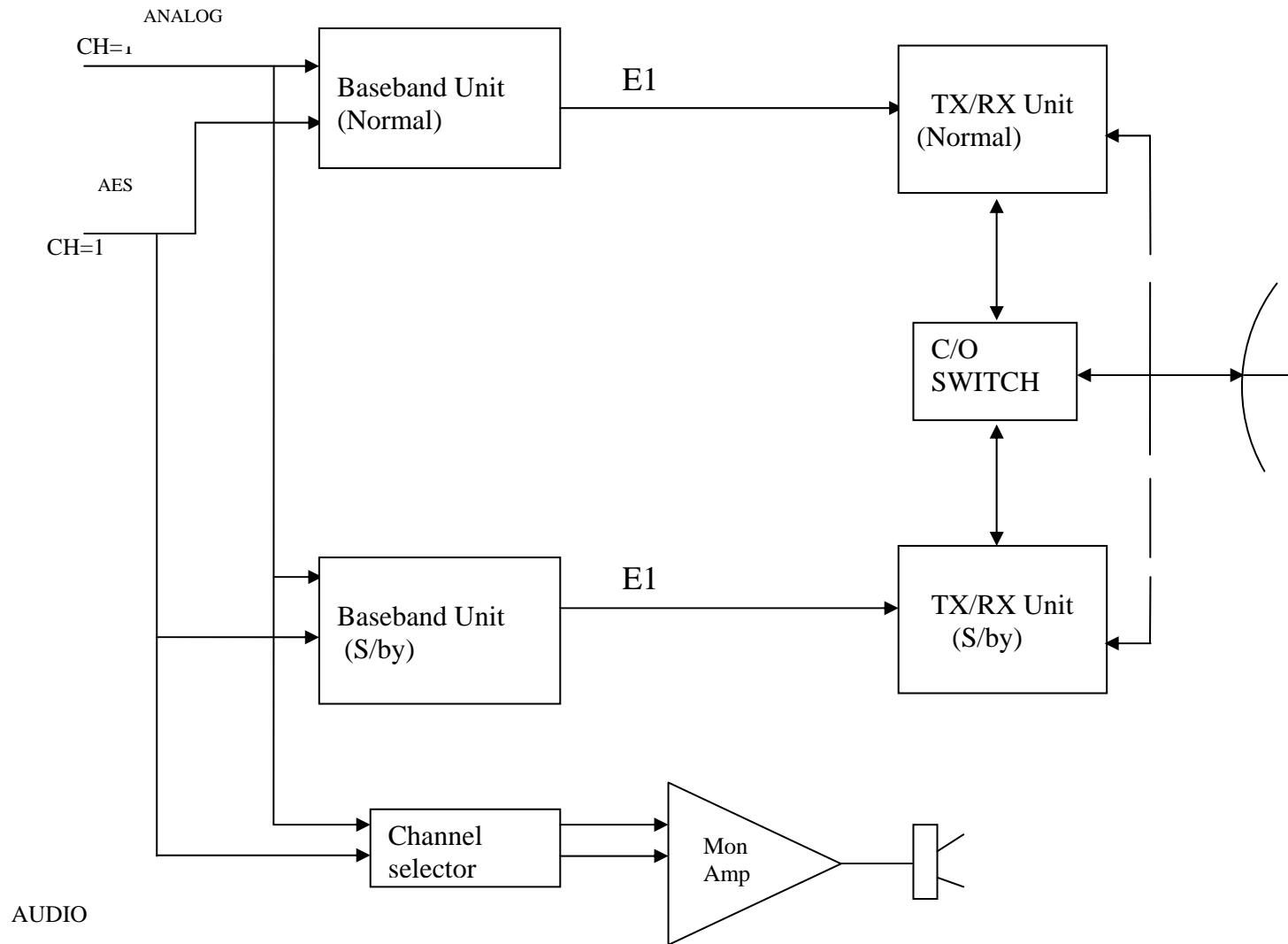

**Note:** Higher configurations will be similarly wired.

**REPRESENTATION DIAGRAM FOR STL AT RECEIVING END FOR 1+1 CONFIGURATION**

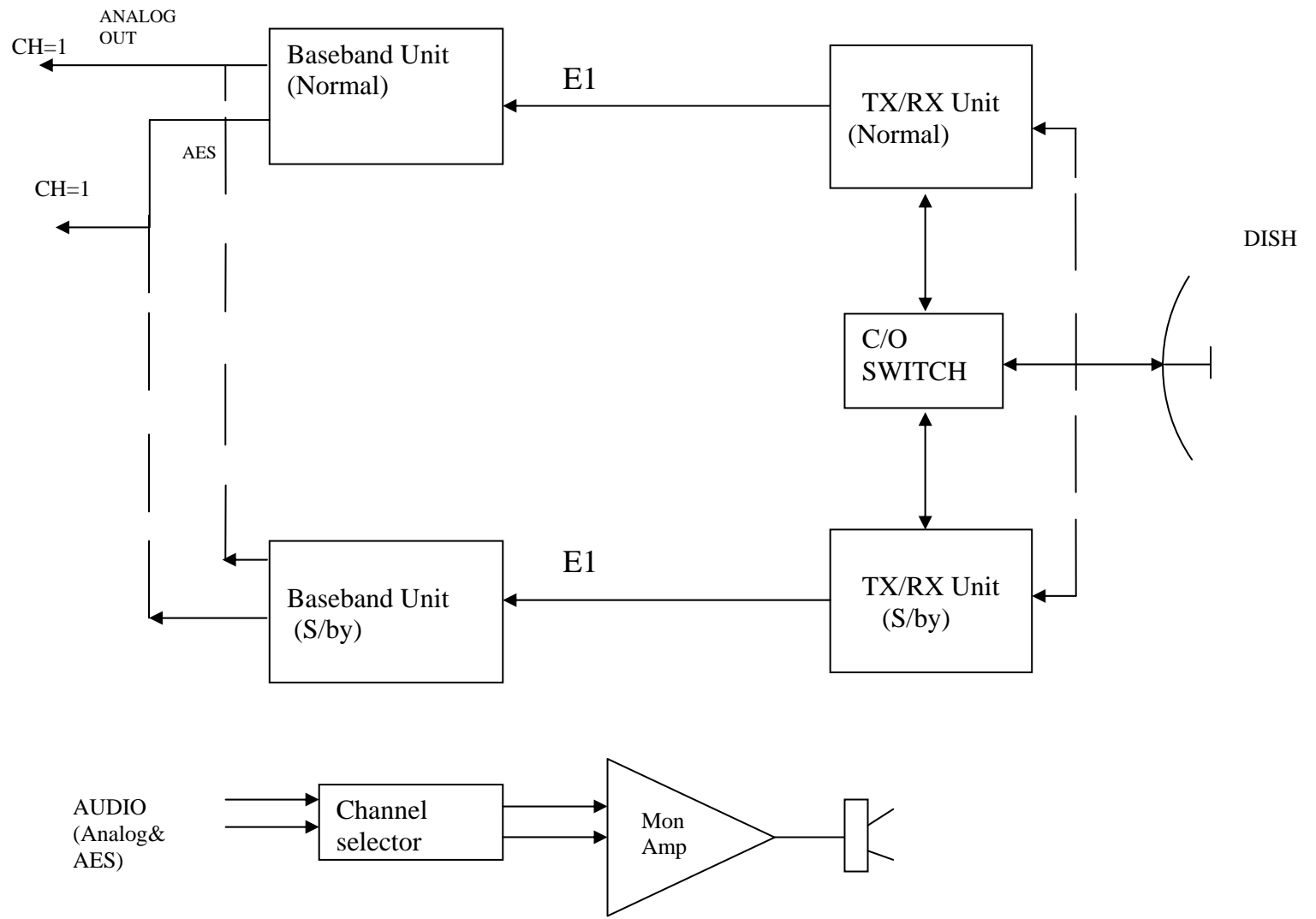

**Note:** Higher configurations will be similarly wired.



