

**PRASAR BHARATI
(BROADCASTING CORPORATION OF INDIA)
DIRECTORATE GENERAL; ALL INDIA RADIO
(PLANNING & DEVELOPMENT UNIT)**

F. No: SETC:10 KW FM TX(1+1) AIR Naushera(Mangla Devi Fort) /J&K / 2010/D(TD/FM)

Specification for Supply, Erection, Testing and commissioning (SETC) of containerized 10 KW (1+1) VHF FM Transmitters and their auxiliary equipment, antenna system setup at Naushera (Mangla Devi Fort) in J&K.

[Total number of pages –158 Nos. plus technical suggestive drawings 11 numbers]

Pre-Bid Conference:

A pre bid conference on technical specifications and other issues shall be held on at Hrs in Conference Hall, Room No. 346, Directorate General, All India Radio, New Delhi-110001, India. All prospective bidders may attend the pre bid conference to discuss their queries/suggestions. All queries/suggestions should be sent at least 2 days before pre-bid conference. No queries/suggestions shall be entertained after pre-bid conference.

Amendments subsequent to the pre bid conference shall be sent to prospective tenderers, who have purchased tender document by e-mail/fax/post. Amendment shall also be posted on All India Radio website www.allindiaradio.org. It shall be tenderer's responsibility to check for any amendments on AIR's website before submitting their duly completed bids.

CONTENTS & ESSENTIAL REQUIREMENTS OF TENDER: (Page number 1 to 4)

PART 1.0 GENERAL SPECIFICATIONS : (Page number 5 to 11)

**PART 2.0 TECHNICAL SPECIFICATIONS:
RADIO EQUIPMENT**

SETC OF;

2.1 10 KW (1+1) VHF FM TRANSMITTER & ACCESSORIES: (Page number 12 to 29)

2.2 16 PANEL VHF FM ANTENNA : (Page number 30 to 40)

2.3 PROGRAMME RECEIVING/FEED FACILITY: (Page number 41 to 57)

(A) RN TERMINAL- C-Band

(B) DTH Ku-Band

(c) EMERGENCY TRANSMISSION FACILITY

2.4 STEREO & DIGITAL PROGRAMME INPUT CUM MONITORING RACK : (Page number 58 to 71)

2.5 MEASURING EQUIPMENT : (Page number 72 to 82)

SETC OF;

2.6 82.5 KVA DG SET (1+1) FOR TRANSMITTER : (Page number 83 to 91)

2.7 62.5 KVA DG SET (1+1) FOR ANCILLARY : (Page number 92 to 97)

2.8 40 KVA UPS : (Page number 98 to 110)

- 2.9 80 KVA AVR : (Page number 111 to 114)
2.10 80 KVA ISOLATION TRANSFORMER : (Page number 115 to 116)
2.11 VENTILATION EQUIPMENT : (Page number 117)

2.12 POWER SUPPLY LT BOARDS & EARTHING SYSTEM : (Page number 118 to 122)
DSETC/SETC OF:
(A) LT PANEL &
(B) EARTHING SYSTEM

2.13 DSETC OF;
CONTAINER FOR RADIO TRANSMITTERS/ : (Page number 123 to 126)
DSETC of CONTAINER FOR POWER SUPPLY
& ALLIED EQUIPMENT SETUP

2.14 TECHNICAL MANUALS FOR TRANSMITTERS SETUPS : (Page number 126)

PART 3.0 INSPECTION: (Page number 127 to 135)

- (A) INSPECTION OF TRANSMITTERS AT TENDERER'S SYSTEM INTEGRATOR WORKS :
(B) ACCEPTANCE OF ASSOCIATED EQUIPMENT, ITEMS & ACCESSORIES AS PER OEM'S TEST CERTIFICATES AT TENDERER'S SYSTEM INTEGRATOR WORKS :
(C) PROFORMA FOR CHECKING VARIOUS POINTS DURING JOINT INSPECTION OF ABOVE SET UP

PART 4.0 : SCHEDULE OF REQUIREMENTS / MATERIALS (UN PRICED) for Supply, Erection, Testing and commissioning (SETC) of containerized 10 KW (1+1) VHF FM Transmitters and their auxiliary equipment, antenna system setup at Naushera (ManglaDevi Fort) in J&K
(Page number 136 to 152)

PART 4.0 SCHEDULE OF REQUIREMENTS / MATERIALS (UN PRICED) [OPTIONAL EQUIPMENT & ITEMS] : THESE WILL NOT BE CONSIDERED FOR RANKING PURPOSE
(Page number 153 to 158)

FOR EACH SITE { The tenderer must quote all items Site Wise }:

- ANNEXURE a: SITE LAY OUT PLAN (DRAWING NO. DGD ND/JKPC=01/R2 with suggestive markings)
ANNEXURE b: SUGGESTIV LAY OUT OF EQUIPMENT OF TRANSMITTER CONTAINER & POWER SUPPLY CONTAINER (DRAWING NO. TM:15951 & TM:15952), PI Rack TM-16003
ANNEXURE c: SUGGESTIVE- Power supply schematic. **(DRAWING NO.TP: 15997)**
ANNEXURE d: SUGGESTIVE -Details of horizontal cable tray. **(DRAWING NO. TM: 14453/3)**
ANNEXURE e : SUGGESTIVE Drawing for Earthing System (DRAWING NO.TM: 15108/3 & TM-15175/2, TM-15165)
ANNEXURE f: Antenna System (Drawing No. TM-15998 & TM-15999)

ESSENTIAL REQUIREMENTS OF THE TENDER:

1. The tender will be submitted in two bid system i.e. technical and commercial bid. The complete tender (technical bid & commercial bid without price) should be submitted in duplicate. **In respect of part No.2.3 & 4.3 separate technical bid shall be submitted by the tenderer in duplicate for technical evaluation.**

SUPPLY:

- 1.1 Tenderer may please note that in case one or more or equipment/items/equipment system in Part 4.0 Schedule of requirements/materials (un priced) is technically not approved by the indenter after technical evaluation, the same will be deleted from equipment/items/equipment system of all tenderer on equitable basis. Thereafter, L1 will be decided on equitable basis out of remaining schedule of requirement/material (unpriced) (Supply)

ETC:

- 1.2 This office will be procuring these items separately & will be provided to the tenderer. ETC will be done by the tenderer.

2. (i)The Tenderer should submit detailed schedule of material /requirement of SETC without price as per Indenter Specification including the (Optional) equipment and recommended spares (Optional) in the technical bid, failing which the tender will be considered incomplete and is liable to be rejected. This list should be in the same format as in the price bid minus the price.

(ii)The tenderer must quote all the items.Tenderer should quote the rate / cost of individual items per number/ per meter/per job in the tender offer. Tenderer should quote the rate / cost of individual items per number/ per meter in the tender offer while submitting the offer for recommended spares in commercial bid.

3. Each statement of this specification has to be complied with & supported by printed technical literature , technical data sheets and technical manuals from the manufacturer of the equipment by the tenderer, to assess the merit of the offer without which tender will be considered incomplete & is liable to be rejected. The tenderer should make a detailed offer.

4. All the technical details, Schematic drawings and schedule of requirement/material must be submitted and enclosed with the tender by the tenderer failing which the tender is liable to be rejected.

5. The tenderer should submit the tender offer to AIR in the format given below Section wise & clauses wise in respect of all the sections of technical specifications {along with column number 5 “Ref to tender page No. by the tenderer as per the offer of the tenderer” in the format given below} in detail to assess the full merit of the offer, failing which tenderer shall be considered incomplete and is liable to be rejected.

6.

Sr. No. of AIR Spec. Section Wise & Clause Wise (1)	Details of AIR Spec. Part/ Section wise & clause wise (2)	Make & Model No of the Equipment offered (3)	Compliance Yes/No (4)	Ref to tender page No. by the tenderer as per the offer of the tenderer (5)	Remarks (6)
Part 1.0 Clause wise					
Part 2.0 Clause wise					
Part 3.0 Clause wise					
Part 4.0 Clause wise					

7. The complete Technical specification (section wise & clause wise) compliance statement along with schedule of requirements/materials (unpriced) must be signed & stamped on each page by the Original Equipment Manufacturer (OEM) of the equipment in the tender document including the clarifications, if any, asked by the Indenter. In case tender offer is from other than the Original Equipment Manufacturer, the tenderer must also sign & stamp each page of the complete Technical specification (section wise & clause wise) compliance statement including the clarifications, if any, asked by the Indenter, failing which the tender shall be considered incomplete and is liable to be rejected. The OEM & tenderers should fill up their name in CAPITAL LETTERS, full address with pin code, phone number, fax number, e-mail address and with their full signatures.
8. The complete tender shall be page numbered.
9. The optional items will not be considered for ranking purpose.
10. The lowest - LI will be decided site wise.
11. Any change in the AIR Technical Specification format or language or in parameters or of any other nature including the deletion of technical specification clause, words, lines in the technical compliance statement as mentioned in clause 6 as above by the Original Equipment Manufacturer/ tenderer will not be acceptable to Indenter and the tenderer is liable to be rejected.
12. Tenderers may please note that no clarifications may be sought by the Indenter from the tenderer and hence all the tenderers may submit their offers with due care.

PART 1.0 GENERAL SPECIFICATION:

Please refer to "Instruction to Bidders" for general terms and conditions of contract including all the commercial aspects for the SETC.

1.0 GENERAL SPECIFICATIONS :

All equipment and items of SETC as per AIR specification should be suitable for 24x7 continuous operation.

Each statement of this specification has to be complied with & supported by printed technical literature, technical data sheets and technical manuals from the manufacturer of the equipment by the tenderer, to assess the merit of the offer without which tender will be considered incomplete & is liable to be rejected. The tenderer should make a detailed offer.

SCOPE:

1.1 Supply, Erection, Testing and commissioning (SETC) of containerized 10 KW (1+1) VHF FM Transmitters and their associated equipment setup at Naushera (Mangla Devi Fort) in J&K as per AIR specification.

The broad scope of above supply, erection, testing and commissioning (SETC) are as follows:

{The tenderer must quote all items }:

RADIO EQUIPMENT

SETC OF;

- 1.2 10 KW (1+1) Digital compatible VHF FM Transmitter & Accessories
- 1.3 16 Panel VHF FM Antenna
- 1.4 Programme Receiving /Feed Facility
 - (A) RN Terminal- C-Band
 - (B) DTH Ku-Band
 - (c) Emergency Transmission Facility
- 1.5 Stereo & Digital Programme Input Cum Monitoring Rack
- 1.6 Measuring Equipment

SETC OF;

- 1.7 82.5 KVA DG SET (1+1) for transmitter
- 1.8 62.5 KVA DG SET (1+1) for ancillary
- 1.9 40 KVA UPS
- 1.10 80 KVA AVR
- 1.11 80 KVA ISOLATION TRANSFORMER
- 1.12 Ventilation Equipment
- 1.13 Power supply LT board & earthing system(A) Design, Supply, Erection, Testing and Commissioning (DSETC) of LT panel & (B) Earthing.
- 1.14 **DSETC OF;** Container for Radio Transmitters, power supply & allied equipment set up
- 1.15 Technical Manuals

2.0 The following are excluded from the scope & will be provided by Indenter:

- 2.1 Plat form for the Transmitter Container.
- 2.2 Construction of necessary office buildings block and connectivity with containers
- 2.3 Electric supply connection for the transmitting equipment, at a single point.

2.4 Plat forms and Sheds for 82.5 KVA (1+1) & 62.5 KVA (1+1) Diesel Generators.

2.5 Diesel Storage tanks.

2.0 For completion of the SETC all items, fittings and accessories which are necessary for the setup , which may not have been specifically mentioned or which the Tenderer may not explicitly mention in the tender but all the same which are necessary for the operation of the equipment will be deemed to be included in the tender and should be provided by the successful Tenderer without any additional payment by the Indenter . The full technical details and technical literature/ pamphlets should be submitted by the Tenderer.

3.0 **INSPECTION:**

3.1 **INSPECTION OF TRANSMITTERS AT TENDERER'S SYSTEM INTEGRATOR WORKS:**
Inspection for Transmitter equipment will be as per details given in this specification by the representative of All India Radio at **Tenderer's System Integrator's works** before dispatch to site

The tenderer shall put up all the Transmitter units to be supplied for Inspection, for exhaustive test on the test bench, at System Integrator's premises before the representative of DG: AIR. The supplier shall provide without any extra charges electric energy, consumable materials, tools, testing instruments, labour and assistance of every kind for carrying out acceptance tests.

Complete specifications and details will be checked and value of all parameter values will be measured. The acceptance to this clause has to be clearly stated by the Tenderer.

Prior intimation for carrying out Inspection at System Integrator's works is to be given by the supplier to AIR at least 6 weeks in advance. Inspection period will be 8 working days. Expenses for inspection charges on account of providing of infrastructure only are to be quoted. The expenditure towards To and Fro journey, lodging, boarding & DA in respect of Inspector will be borne by AIR.

3.1.1 **The tenderer will state clearly the name of place of the tenderer's integrator's works in the tender offer, failing which the tenderer will be considered incomplete and is liable to be rejected.**

3.2 **INSPECTION / ACCEPTANCE OF ASSOCIATED EQUIPMENT, ITEMS & ACCESSORIES AS PER OEM's TEST CERTIFICATES AT TENDERER'S SYSTEM INTEGRATOR WORKS :**

All other associated equipment, items and accessories should be complete in all respects and fully sourced from their Original Equipment Manufactures (OEM).

All associated equipment, items and accessories will be accepted on the basis of OEM's test certificates duly signed & stamped on the letter head of the OEM, failing which OEM's test certificate will be considered in complete & equipment offered by the tenderer is liable to be rejected.

Test certificates duly signed and stamped by OEM in respect of associated equipments & accessories as per technical specification are to be furnished by the tenderer to AIR before giving call for inspection.

3.3 **INSPECTION: Joint Inspection of the setup at site:
AS PER PROFORMA FOR CHECKING VARIOUS POINTS DURING JOINT INSPECTION
OF ABOVE SET UP.**

(i) Performance measurement will be carried out during Joint inspection in respect of Transmitter equipment, DG sets and UPS at **site** as per OEM test certificate duly stamped and signed by OEM.

(ii) All other associated equipments, items and accessories will be accepted as per 3.2.

(iii) For details of joint inspection of the set up at site , please refer Part 3.0 (C)

3.4 Draft Acceptance Test Procedure will be submitted by the Tenderer within one month of placement of order for approval of AIR in respect of SETC. This will include all tests so as to assess the performance of the equipment/items/equipment system as per technical specification.

4.0. The successful Tenderer should supply within one month from the date of placement of the order, 2 sets of complete design & drawing documents in respect of the setup for the approval of AIR. Tenderer should submit detailed design, complete drawings with full details as per the specification.

5.0 All the necessary measuring equipment and tools etc. required for completion of the project will be arranged by the Tenderer during SETC and no additional amount would be paid on this account.

6.0 Erection, testing and commissioning (ETC) of above “set-up” as per specification shall be done under the supervision of Qualified Engineer of OEM duly trained and certified by OEM of main equipment i.e. transmitter and antenna at site.

7.0 INFORMATION TO BE SUPPLIED BY THE TENDERER IN DUPLICATE:

7.1 All information submitted by the Tenderer & all markings, notes, designation on the design, Drawing documents & associated write-ups should be in "English language" only.

All dimensions and units on drawings and all references to weights and measures and quantities should be in MKS.

A complete compliance statement to complete technical specification of indenter para-wise for each clause is to be submitted by the tenderer to assess the merit of the offer without which tender will be considered incomplete and is liable to be rejected.

7.2 Each statement of this specification has to be complied with & supported by printed technical Literature, technical data sheets and technical manuals from the manufacturer of the equipment by the tenderer, to assess the merit of the offer without which tender will be considered incomplete & is liable to be rejected. The tenderer should make a detailed offer.

7.3&74 Please refer the points 3 & 6 of essential requirements of the tender.

7.5 Complete Technical manual including datasheets for the offered Equipments must be submitted by the tenderer to assess the full merit of the offer, failing which the tender shall be considered incomplete and is liable to be rejected.

7.6 Complete set of *Technical* drawings / Engineering drawings giving full details and dimensions of equipment / items are to be submitted with tender, failing which the tender shall be considered incomplete and is liable to be rejected..

7.7 Descriptive information giving complete details of each equipment offered should be given by the Tenderer.

7.8 Country of Origin ,Make, model and type of individual units along with printed technical details should be given by the Tenderer.

8.0 Tenderer should submit detailed schedule of material/requirement of Supply, erection, testing and commissioning (SETC) without price as per specification, failing which the tender shall be considered incomplete and is liable to be rejected. This list should be in the same format as in the price bid minus the price.

9.0 In support of Tenderer's claim an "up-to-date" list of their customers including their full address, Telephone/Fax No & E-mail address is required to be submitted along with complete set of performance figures along with the tender by the tenderer.

The offered equipment/items shall be field proven for satisfactory operation. A supply record of transmitters, RF cable and antenna, DG Sets, UPS, AVR, Isolation Transformer year wise in the last 5 years may be enclosed by the tenderer.

10.0 In case of 'kits' complete details of all components that form part of kit should be spelt out/clearly given i.e. the details of the component/item offered in the kit including their part no. and quantities.

11.0 INFORMATION TO PRECEDE DESPATCH OF EQUIPMENT:

Following information should be supplied to Indenter and each of the consignees, prior to dispatch of equipment:

11.1 Detailed list of equipment under dispatch.

11.2 Photographs with illustration, detailed engineering drawings showing location/details of components in the various units and sub units with Item/part number marked thereon.

12.0 SUPPLY, ERECTION, TESTING AND COMMISSIONING :

Supply, Erection, Testing and commissioning (SETC) of containerized 10 KW (1+1) VHF FM Transmitters and their auxiliary equipment along with antenna set up at Naushera (Mangla devi Fort)TV Site in J&K, on turnkey basis.

12.1 TESTING:

10 KW (1+1) VHF FM Transmitters and their auxiliary equipment setup in a container are to be tested after the erection, after making all the initial checks including physical inspection and continuity checks of wiring/cabling etc. as per drawings. Only after satisfying that erection is fit for testing (without the application of RF power), the testing will be taken up with RF power in a sequential manner in respect of all the equipment. The testing will be undertaken by the Tenderer as per standard practice and in conformity with procedure laid down in ATP/ OEM test Certificate.

12.2 ERECTION/INSTALLATION, TESTING AND COMMISSIONING :The Transmitter and associated equipment and accessories will be installed, tested and commissioned by Tenderer in accordance with the instructions and drawings of manufacturer and as per approved ATP.

13.0 On acceptance of the tender, the name of the accredited representative(s) of the Tenderer who would be responsible for taking instructions from DG: AIR, New Delhi-110001 or his authorized representative should be communicated in writing to DE (Project), P & D Unit, DG, AIR.

14.0 Transmitter and auxiliary equipment {10 KW (1+1) VHF Digital compatible FM Transmitters should be compact in size and should fit in a container.

15.0 Optional items will not be considered for ranking purpose.

16.0 Experience (Supply): Minimum 10 years experience of OEM in production of the products quoted unless otherwise mentioned in this specification else where.

Tenderer may submit offer through their OEM. The OEM should have experience of 10 years unless otherwise mentioned else where in this specification.

17.0 AFTER SALES SERVICE :

SERVICE FACILITY: The Tenderer shall specify the repair/service facility available for the equipment in India with address, Phone/Fax nos., E-mail etc. The supply of transmitter may require after sales services. Therefore full details of facilities for carrying out after sale service may be given.

Tenderer shall have to respond quickly after getting intimation from indenter for the service of equipment/ rectification of fault of the equipment.

18.0 PACKING AND PACKING LISTS :

All the equipment should be securely and properly packed to withstand transit hazards. Equipment packing shall be fit for sea freight and incorporate adequate protection against ingress of moisture. Packing slips giving details of the items contained in each package shall be placed inside the package in a water proof envelop to enable easy identification and should contain cross references to item/part numbers of installation drawings/components lists. Copies of packing slips and other details should be sent separately to respective consignee and also to The Director Engg. (Projects), P & D Unit , DG: AIR, New Delhi.

19.0 INSURANCE AND MARINE RISKS ETC.

Please refer to commercial terms.

20.0 GUARANTEE: Tenderer shall submit with his tender an undertaking to accept the following guarantees unless otherwise mentioned any where in the specification, In that case guarantee mentioned in the relevant clause of specification will be applicable.

(i) A guarantee that the equipment supplied will be in accordance with these specifications, varied only to the extent stated in tender's offer and agreed to in the contract.

(ii) A guarantee to make good within 30 days at tenderer expense any component which becomes defective under normal operating conditions during 18 months from the date of acceptance of the equipment at respective site or 12 months from the date of commissioning at site whichever is earlier.

(iii) A guarantee to supply all components for a period of 10 years from the date of acceptance of equipment at site, at rates at which these are being supplied by tenderer to other customers & also should match prices of original manufactures of these components prevailing at the time.

(iv) If at any stage, during next 10 years, the manufacturer stops production of this model of equipment, tenderer shall intimate All India Radio in advance to enable the Indenter to stock the critical items.

21.0 SITE DETAILS: Naushera (Mangla Devi Fort).

HAMSL: 855M

Latitude: 33° 05' 45"N

Longitude: 74° 17' 10"E

22.0 ENVIRONMENTAL CONDITIONS for transmitter and all associated equipment:

Ambient temperature range for operation : 0° C to + 45° C

Relative humidity: 95 percent, non condensing.

Rain: Up to 10 cm/hr

Outside Temperature for transmitter container -30°C to 55°C

23.0 Wind Speed : for C band, DTH and all cabins for security staff, operating staff, sentry post, pump room (optional)

Operational Wind speed : 80 Km per hour

Maximum wind speed for survival: 150 Km per hour

24.0 Wind speed for antenna: Maximum Wind Speed 198 km. per Hr.

25.0 Power Supply for Three Phase Equipment:

Operating Line Voltage: AC Three phase, 4 wire, 400V ± 10 %,

Frequency: 50Hz ± 4 %

Power Factor: Better than 0.9

26.0 Power Supply for Single Phase Equipment:

Operating Line Voltage: AC Single phase, 230V ± 10 %,

Frequency: 50Hz ± 4 %

Power Factor: Better than 0.9

27.0 The Tenderer shall make his own arrangements for providing accommodation for his workmen at site along with storage of equipment/ material including the safe custody at site.

28.0 The Tenderer should conform to all local State laws/Central laws and regulations amended up to date concerning labour and their employment as applicable. The insurance etc of the labourers shall be the responsibility of the Tenderer including any kind of pre /post action and consequences relating to above insurance etc.

29.0 The Tenderer shall indemnify and hold harmless the purchaser, his employees and purchaser's employees from any liability that may arise out of infringements of patents and copy rights associated with the design, fabrication, erection of any equipment etc.

30.0 The Tenderer is required to submit details of his previous experience in similar supply of such Equipments i.e. the capacity of their organizational setup. Tenderer should have minimum of 5 years experience in similar supply of such equipment.

31.0 After completion of SETC the Tenderer shall remove dust, dirt, debris and leave the premises in a clean condition.

32.0 The successful tenderer should indemnify and hold harmless the purchaser's against all claims in respect of damages to buildings, property, articles, situated nearby not belonging to the purchaser, and public personnel arising from the Supply, Erection, Testing and Commissioning.

33.0 The successful tenderer should indemnify and hold harmless the purchaser against claims in respect of injury to any person howsoever arising from the Supply, Erection, Testing and Commissioning.

34.0 TRAINING: At AIR Site (OPTIONAL).

The tenderer shall train 10 engineers for 5 working days to enable them to become acquainted with all particulars as well as installation, operation, trouble shooting and maintenance of the Transmitter, Auxiliary Equipment & accessories.

The training programme will be structured so as to cover theory of operation, Maintenance, Practical demonstrations of circuits, Fault finding, Circuit Tracing exercises and Part Replacements. For Training of Engineers expenses toward to and fro air journey, boarding, lodging etc. will be borne by All India Radio.

Two sets of training lecturers notes, schematic drawing, hand book etc. shall be supplied to DE (Project) P&D Unit, DG: AIR.

35.0 INFORMATION TO BE SUPPLIED BY THE TENDERER AFTER AWARD OF SUPPLY ORDER :

One set of Technical manuals {for Installation, testing, commissioning, Operation & Maintenance, including Theory of operation and fault diagnosis printed and duly bound for all equipment under Part 2.0 along with one soft copy on CD shall be supplied to “The Director Engg. (Projects), P & D Unit, DG: AIR, Delhi-110001” within two month of placement of order. All the details should be complete & exhaustive. One soft copy of these documents is also to be sent on CD.

36.0 INFORMATION TO BE SUPPLIED ALONG WITH EQUIPMENT:

36.1 For each equipment system/equipment/items of Part 2.0, two printed & duly bound copies of Technical manuals along with duly filled ATP, Inspection Report/ OEM test certificate of associated equipment and soft copy are to be supplied to each consignee.

36.2 These Technical manual documents along with Inspection Report & other OEM test certificates are required to be sent to the officers / offices / places as per Part 4.0

37.0 COMPLETION OF SETC: Eight (8) months from the date of placement of purchase order.

38.0 The tenderer shall supply a complete schedule of Supply, Erection, Testing and Commissioning of the containerized Transmitter along with all associated equipments/items and installation materials.

39.0 **Overall CEA clearance:**

Tenderer will be required to get CEA Overall clearance in respect of all the power supply system, normal power supply, DG Sets, UPS, Transformer, power supply switch gear, power supply cables etc. at site.

40.0 The quote should either be from the original manufacturer or from their authorized representative/dealer. In case, the quote is from the authorized representative/dealer, a certificate in original from the original manufacturer that the tenderer is authorized representative/dealer for India should be enclosed with the tender, failing which tender shall be considered incomplete & liable to be rejected.

41.0 The SETC system (Antenna installation) will be done by the tenderer during night hour (non transmission hour). Therefore, tenderer should quote accordingly.

PART 2.0 TECHNICAL SPECIFICATIONS

2.1 DETAILED TECHNICAL SPECIFICATIONS FOR SETC OF 10 kW VHF FM SOLID STATE BROADCAST TRANSMITTER UNIT IN (1+1) CONFIGURATION WITH AUTOMATIC CHANGEOVER UNIT

SECTION- I GENERAL

2.1. Brief Description:

Two nos. of 10 kW VHF FM transmitter units in 1+1 auto mode shall be supplied with each set of Transmitter. The operation in (1+1) mode is done by an Automatic changeover Unit (ACU).

The broad scope of the supply and schedule of requirement is as follows:

- 2.1.1 10 KW VHF FM(1+1) TRANSMITTER (in active/ hot standby operation) & accessories, including Dummy Load, Dehydrator, Mod. Monitor, Digital Audio Broadcast Audio Processor, RF Co-axial switch etc. i.e. Complete setup as per specifications.
- 2.1.2 Test & Inspection of transmitter at tenderer's systems integrator works: Please refer Part 3.0.
- 2.1.3 INFORMATION TO BE SUPPLIED WITH THE TENDER IN DUPLICATE : Please refer Part 1.0 &
 - 2.1.3.1 Layout of equipment of Transmitter and external units including dimensions, weights, overall sizes & photographs/ illustrations of the interior of the Transmitter.
 - 2.1.3.2 Transmitter Block diagram/ Schematic drawings and its subsystems.
 - 2.1.3.3 Technical data sheet of all high power semiconductor devices used in the equipment.
 - 2.1.3.4 A supply record of 10 KW VHF FM transmitters power wise and year wise in the last 5 years shall be enclosed by the tenderer. Names, Address, E-mail, telephone nos. and Fax numbers of customers must be given.
 - 2.1.3.5 A complete set of performance figures of similar Transmitter, auxiliary equipment and accessories (duly certified by the customers) may be furnished along with the tender.
- 2.1.4 INFORMATION TO BE SUPPLIED BY THE TENDERER AFTER AWARD OF SUPPLY ORDER:
Please refer Part 1.0.
- 2.1.5 INFORMATION TO PRECEDE DESPATCH OF EQUIPMENT: Please refer Part 1.0.
- 2.1.6 INFORMATION TO BE SUPPLIED ALONG WITH EQUIPMENT: Please refer Part 1.0.
- 2.1.7 GUARANTEE: Please refer Part 1.0

SECTION II TECHNICAL DESCRIPTION OF RADIO TRANSMITTER

2.0 TRANSMITTER CONFIGURATION:

Two nos. of 10 kW VHF FM transmitter units in 1+1 auto mode shall be supplied to site.

2.1 10 KW solid state MOSFET technology VHF FM Transmitter without tuning (frequency agile) shall be capable of giving ≥ 10 kW power continuously. It should consist of a number of low power hot pluggable modular power amplifiers.

2.2 (a) Two nos. of 10 kW VHF FM transmitter units in 1+1 auto mode shall be supplied with each set of Transmitter in 1+1 configuration. Both the 10 kW VHF FM transmitter units shall be configured to operate in (1+1) mode. The second 10 KW VHF FM Transmitter unit will work as hot or active standby in automatic change over mode (with manual override) which will also incorporate auto audio changeover. The operation in (1+1) mode is done by an Automatic changeover Unit (ACU).

The automatic changeover of Transmitter should take place when power of active Transmitter goes down by ≥ 3 dB.

(b) Each Transmitter will be provided with two nos. of Exciter units (i.e. 4 nos. of Exciters for one complete set). The second Exciter unit will work in a passive standby mode.

(c) 10 kW VHF FM (1+1) mode transmitter should have provision for automatic switching of either 10 kW transmitter to the Antenna & Dummy load

2.3 The Transmitter will be complete in all respects. AIR will provide power supply of three phase, 4 wire, 400 Volt (rms) $\pm 10\%$, 50 Hz $\pm 4\%$ at a single point. All other transmitter's subsystems should derive supply through this source.

No other voltage will be acceptable to AIR at the Transmitter's input circuit breaker and failing which the offer is liable for rejection.

The performance of transmitter as per parameters in Section-III should be ensured without degradation with the given power supply tolerances.

2.4 The Transmitter should be suitable for unattended 24 x7 operation. The Transmitter should be suitable for Mono and Stereo FM Radio Broadcast.

2.5 Transmitter equipment metal works should be protected against rust and corrosion. All materials should be non-inflammable and fire retardant.

2.6 All stages i.e. Exciter, IPA,(as the case may be) PAs, Combiner, harmonic filters, etc. should be capable of operation in the entire VHF frequency band i.e 88 to 108 MHz **with out** change of components/settings/tuning.

2.7 Transmitter should be of modular design for easy maintenance & part replacement. It should be possible to take out PA module without "switching off" the transmitter..

- 2.8 The Transmitter construction should ensure complete shielding of high power RF radiation coming from TV Transmitters in VHF & UHF band as well as other FM Transmitters located near the containerized transmitter. Therefore, the transmitter should be adequately protected from resultant E.M.I. (Electro Magnetic Interference) as per ETS-300447.
- 2.9 It should comply with IEC 215 safety standards so as to eliminate hazards to personnel. Access to parts carrying dangerous voltage should be through interlocked doors.
- 2.10 The Transmitter will consist of solid state devices and have only MOSFETS in (IPA, if applicable)/PA stages. It must have Auto Ramp Up circuit for power rise when Transmitter is “Switched-On”. It should be possible to vary the Transmitter power from a low value to full value from front panel control on controller. Details to be provided by tenderer.
- 2.11 Exciter:-**
- 2.11.1 The Exciter should have Digital Signal Processing (DSP). Exciter should accept analog mono, analogue stereo (left and right) / encoded stereo signals (MPX),DARC, SCA inputs and AES / EBU digital inputs. It should be compatible for mono and Stereo Broadcasting using pilot tone system conforming to ITU-R, Rec.450.
- 2.11.2 All the input modules mentioned in 2.11.1 must be included in the offer of Exciter i.e. either inbuilt or separate input modules to be used in one or same slot (Digital stereo Input/Output AES/EBU module & Analogue stereo Input/Output modules).
- 2.11.3 It should have its own manually adjustable power control. The pre-emphasis should be Selectable / Switchable.
- 2.11.4 It should display various parameters like forward and reflected power, frequency deviation, input-audio level, DC voltages & currents, on its panel meters or LCD display. Status and faults should also be indicated. List of meters / display, measured parameters, LED’s & status / fault indications to be enclosed.
- 2.11.5 It should be Synthesized with easy channel selection of minimum 100 KHz spacing i.e. can be operated on any of the FM channels from 88 MHz to 108 MHz in VHF Band-II. The Exciter should be “Frequency agile” --- not requiring any tuning over its entire specified operating frequency range.
- 2.12 Intermediate Power Amplifier Modules :(If Intermediate Power Amplifiers are provided as per design of manufacture): IPA Modules should be capable of operation in the entire VHF frequency band, 88 to 108 MHz without tuning. Redundancy for IPA is required.
- 2.13 Power Amplifier Modules: Total transmitter output power will be developed by an optimum combination of PA Modules and should be capable of operation in the entire VHF frequency band, 88 to 108 MHz without tuning. Each of the PA should be inter changeable in any position. The efficiency figures for each PA are to be indicated.
- 2.14 Combiner Unit: The final power combiner should be of such type so as to be capable to operate in entire 88-108 MHz without any tunning & change of components/settings.
Tenderer should offer each 10 KW VHF FM transmitter in a single rack unit. No other combination

should be acceptable.

The Insertion & Return Loss figures with full details of the combining unit along with schematic diagrams should be enclosed with the tender.

Tenderer in the following format should indicate the reduction in transmitter RF output power in case of failure of individual power amplifier module units.

SNo.	Number of PA modules/units failure	Transmitter RF output power in kW
1.	one No. kW
2.	two Nos. kW
3.	three Nos. kW
.... kW
N	N...Nos. kW

2.15 Final Output Harmonic Filter for Transmitter: The final Output / Harmonic Filter should be capable of operation in the full VHF Band 88 to 108 MHz without tuning. The details along with schematic diagrams should be enclosed in the tender.

2.16 Protection System : Adequate protection system should be provided to safe guard the system from damage under fault conditions. The protection system should be fast acting to safe guard the system and components.

2.17 Control and Interlocking:

2.17.1 The Control and Interlock circuits should ensure protection and operational safety of the equipment and personnel. They should allow the Transmitter to be "Switched-in" Or "out-of-service" in a proper sequence only by operation of switch buttons or manual controls on transmitter panel. Switching-in of the auxiliary units such as Dummy Load, reject-loads, exhaust fan etc. should be suitably interlocked. External units and accessories like Dummy Load, Change over switches etc. should be wired in Transmitter interlock.

2.17.2 Details of the control/monitoring/protection unit should be given.

2.17.3 It should be possible to switch off the entire Transmitter in emergency by the operation of a single push button/ manual command. This should be on front panel.

2.18 COOLING SYSTEM:

Full details of cooling system and blowers should be given. Temperature rise of air for rated power output is to be indicated. Details of cooling system should be given. Blowers used must be within the Transmitter cubicles.

2.19 TRANSMITTER POWER SUPPLY:

Transmitter should have its own input circuit breaker for the mains supply. The transmitter's inbuilt power supply system should be able to take care of specified variations in the main supply i.e. Tr. should comply with three phase, 4 wire, 400 Volt (rms) $\pm 10\%$, 50 Hz $\pm 4\%$.There should not be more than 5% imbalance in the phase currents for transmitter power from 1kW to 10kW. Technical data power wise from 1kW to 10 kW should be enclosed with the tender.

SNo.	Tr power	Line current A	Line current B	Line current C
1.	1kW			

2.	2kW			
3.	4kW			
4.	5kW			
5.	7kW			
6.	8kW			
7.	9kW			
8.	10kW			

The rectifier and filter circuits should be able to take care of switching voltage surges on power lines. The AC and DC supply should have their protective devices. Adequate metering / indications like DC voltage and current to be provided. Power supply unit to be protected against "over temperature", "over-current" and "over-voltage", transients etc.

2.20 **SPARES (OPTIONAL):** The tenderer should quote for one set of spares as per Part 4.1(B).

TECHNICAL SPECIFICATIONS OF THE AUTOMATIC CHANGEOVER UNIT,

2.23 AUTOMATIC CHANGEOVER UNIT (ACU):

- (i) One Automatic Changeover Unit (ACU) for operating the Transmitter in (1 + 1) mode to facilitate automatic switch "ON" of the 2nd Transmitter Unit in case of failure of RF output of 1st Transmitter Unit shall be offered by the tenderer with each set.
- (ii) Any one of the 10 kW FM Transmitter unit shall be selectable as master or slave automatically in active stand by mode. When the RF power of the 1st transmitter goes down by more than 3 dB, it should be sensed as a failure to switch to second transmitter automatically. In case of failure of the complete system, three trials at interval adjustable up to 10 minutes shall be done before final switch off.
- (iii) The audio shall be fed to both the Transmitter Units from external sources (C band & Ku band system) and therefore, proper arrangement of feeding the audio in Changeover Unit and permanent feeding to both the Transmitters shall be made. In case of audio failure, an indication shall be displayed in the front panel of ACU.
- (iv) The complete switching sequence of transmitter and associated equipments may be provided with the technical offer.
- (v) Arrangement shall be made for bypassing the ACU in case of its failure so as to enable operating personnel to operate the transmitter in the manual mode.
- (vi) Power Supply to the ACU shall be fed through the UPS.
- (vii) The changeover time between the two transmitters should be ≤ 30 seconds.

2.24	REMOTE CONTROL AND TELEMETRY (OPTIONAL)
2.24.1	The transmitter shall be controllable from distant location using dial up connection, internet based IP address technique as well as locally. The PCs, modems, and allied equipment for this shall be part of the SETC of the transmitter. The remote control and telemetry link shall be provided by AIR.

Specification no: SETC-10 KW TX (1+1) Naushera (Mangla Devi Fort) /J&K / October/ 2010/D (TD/FM)

	System shall be such that an engineer sitting at a distant location can control and monitor FM transmitter by connecting the PC to the web through telephone lines (Via broadband connection etc.) as well as using a dial-up connection through modem.
2.24.2	Transmitter should be provided with Remote Control and Telemetry Interface Card and equipment to operate it from a distant location via ISDN/Digital line/TCP-IP/ PSTN network/Dialup Connection.
2.24.3	The Remote Control software should be Graphical User Interface based and the screens should be clear and intuitive to the operator. The screen layout should contain mimic diagram of AC mains flow and Audio/RF Flow separately.
2.24.5	Details of control parameters & indications/metering shall be given.
2.5	Optional- A set of RF, DC power supply cables and control cables with appropriate connectors , extender cables and extender cards etc.
2.6	The system should have facility/feature for storage of fault status & storage of readings of the transmitter system

SECTION-III TECHNICAL SPECIFICATIONS OF TRANSMITTER

SNNo.	TECHNICAL PARAMETER	TECHNICAL SPECIFICATION
3.1	GENERAL	
3.1.1	Frequency Range	: 88 to 108 MHz.
3.1.2	Class of Emission	: 180 KF8E.
3.1.3	Stereo transmissions	: Acc. to ITU-R Rec. 450 (Pilot tone).
3.1.4	Nominal Frequency deviation	: +75 KHz (peak)
3.1.5	Maximum Frequency Deviation	: +100 KHz (peak)
3.1.6	Pre-emphasis	: 0, 50 and 75 micro seconds (selectable).
3.2	RF OUTPUT:	
3.2.1	Rated output power	: ≥ 10 kW
3.2.2	Rated output(Load)impedance	: 50 ohm unbalanced.
3.2.3	Permissible VSWR	: 1.4: 1 with full power; Power fold-back beyond 1.4: 1 ; Details of power fold back characteristics to be provided.
3.2.4	Harmonics suppression and Spurious	: Within limits as per Radio Regulations & ITU-R Recommendations. Actual values to be indicated.
3.2.5	Overall efficiency	: ≥ 60 %
3.2.6	Transmitter RF Power output connector size	: 3-1/8"with EIA flange
3.2.7	Max. Frequency tolerance	: As per ITU (R)
3.2.8	Synchronous AM S/N at reference to 100% AM modulation at 400 Hz , 50 micro seconds Pre-emphasis with FM modulation at 75 KHz Deviation	: Better than 50 dB
3.2.9	Asynchronous AM S/N <i>unweighted</i> , referred to 100% AM modulation at 400 Hz , 50 micro seconds Pre-emphasis and without FM modulation.	: Better than 55 dB
3.3	INPUTS:	
3.3.1	<u>Modulating input signal</u>	:Exciter should accept analog mono, analogue stereo (left and right) / encoded stereo signals (MPX), DARC, SCA inputs and AES / EBU digital inputs. It should be capable for mono and Stereo Broadcasting using pilot tone system conforming to ITU-R, Rec.450.

3.3.2	<u>Input impedance (Analog)</u> <u>Input impedance (Digital)</u>	600 ohm or greater, selectable(for mono) 2 K ohm or greater selectable(for stereo) 110 ohm .
3.3.3	<u>Analog and Digital input level</u> for ± 75 KHz (peak) deviation:	ANALOG AUDIO INPUT: At 1 KHz , 0 dBu : Input Level Adjustable from -6 dBu to +12 dBu . DIGITAL AUDIO INPUT: At 1 KHz : Input Level Adjustable from 200 mV to 10 V p-p
3.4	POWER SUPPLY	
3.4.1	<u>Power</u>	: Three phase, 4 wire as per part 1.0
3.4.2	Variation between Phase Currents	Not more than 5% for transmitter power from 1kW to 10kW.
3.5	MONO OPERATION	
3.5.1	S/N ratio at 75 KHz deviation (30 Hz to 15 KHz base band) rms, unweighted	: ≥ 70 dB
3.5.2	THD + N	: Better than 0.15 %.
3.5.3	IMD SMPTE 60 Hz / 7 KHz , 4:1 , +4dBu	: Better than 0.20 %.
3.5.4	Amplitude response 30 Hz to 15 KHz	: Better than ± 0.5 dB
3.6	STEREO OPERATION :	
3.6.1	Stereo separation (sine wave) : 30 Hz to 15 KHz	:Better than 50 dB
3.6.2	Linear Cross Talk referred to 100% modulation: (30 Hz to 15 KHz)	: Better than 50 dB
3.6.3	Non-linear Cross Talk referred to 100 % modulation.	: Better than 60 dB
3.6.4	S/N ratio at 75 KHz deviation (L or R) (30 Hz to 15 KHz Band Width) rms, unweighted	: Better than 70 dB
3.6.5	THD + N(L or R)	: Better than 0.15 %.
3.6.6	IMD SMPTE (L or R) 60 Hz / 7 KHz , 4:1 , +4dBu	: Better than 0.20 %.
3.6.7	Amplitude response	: Better than ± 0.5 dB

	(L or R)30 Hz to 15 KHz	
3.6.8	Pilot tone Stability :	: As per ITU(R)
3.7	WIDEBAND COMPOSITE OPERATION:	
3.7.1	FM S/N ratio at 75 KHz deviation rms, unweighted	: Better than 70 dB
3.7.2	THD+N (Total Harmonic Distortion plus Noise)	: Better than 0.15 %.
3.7.3	IMD (SMPTE) 60 Hz / 7 KHz , 4:1 , +4dBu	: Better than 0.20 %.
3.7.4	Amplitude response 30 Hz to 100 KHz	: Better than \pm 0.5 dB

3.9 REMOTE CONTROL AND TELEMETRY SYSTEM/VSAT/DIALUP CONNECTION: OPTIONAL)

S.No.	Technical Parameter	Specification
3.9	Remote control and telemetry/ Controllable Setting / Monitoring Parameters:	<ol style="list-style-type: none"> 1. Transmitter: ON/OFF in (1+1) configuration 2. Exciter ON/OFF, Audio input level , 3. Exciter RF forward and reflected power 4. RF Output Power Level: 5. Program 1/ Program 2 selection 6. DG Set On/Off 7. UPS Status 8. Power supply status of Voltages, currents 9. Alarm/ Indications: VSWR, Voltage and Current, Temperature, over drive alarms (Over Current, Over Voltage) Individual Unit faults and indications, Temperature, VSWR, ON AIR, Audio etc. 10. Co-axial Switch Position 11. Any other parameter which the manufacturer considers essential for proper functioning of a remote-controlled FM Station.
3.9.2	Data Format	To be indicated by tenderer and compatible for above system.
3.9.3	Data Rate	To be indicated by tenderer and compatible for above data format
3.9.4	Modem Speed	To be indicated by tenderer and compatible for above data format/rate to be used for a distant/centralized location via ISDN/Digital line/TCP-IP /PSTN network/Dial up connection telephone lines.
3.9.5	Computer System	Latest generation, Core 2 Duo processor equivalent or higher, 14" screen, RAM-4 GB, Windows-7 operating system, HDD-320 GB, DVD-RW, 2 USB ports, Card Reader
3.9.6	Software and hardware items to be given by the tenderer	Complete software, hardware items, accessories, single/ multi core cables, RF cable connectors, Humidity/temperature transducer, 2/3 Core Shielded Teflon cable , Extension cables etc. (Items wise details of offered and included material, items & part are to be given by the tenderer)

ANNEXURE-I

TRANSMITTER TECHNICAL DATA TO BE SUBMITTED BY THE TENDERER

S.No.	TRANSMITTER TECHNICAL DATA TO BE SUBMITTED BY THE TENDERER	DETAILS TO BE SUBMITTED BY THE TENDERER	COMMENTS OF TENDERER WITH TECHNICAL DATA / SCHEMATIC DRAWINGS Nos
AII 1.0	Transmitter Dimensions:	Width : (mm) Depth : (mm) Height : (mm)	
AII 2.0	Transmitter weight :	(kg)	
AII 3.0	Transmitter Heat dissipation at 10 kW RF output : KW x 3412 = BTU / Hr	BTU/ Hr	
AII 4.0	Tr AC requirement :	Ton	
AII 5.0	Tr Cooling air requirement:	cubic ft / min cubic M / min	
AII 6.0	Number of Rack	Number	
AII 7.0	Size of Racks: Tr rack Dimensions:	Width : (mm) Depth : (mm) Height : (mm)	
AII 8.0	Air filters Size	Width : (mm) Depth : (mm) Height : (mm)	
AII 9.0	Blowers: Total no. of blowers	Number	
AII 10.1	Power consumption at 10 kW RF output:	kW	
AII 10.2	Power consumption without delivering any RF output:	kW	
AII 11.0	Typical Power supply line voltages (phase to phase voltages)		
AII 11.1	Voltage between Red phase & Yellow phase:	Volt	
AII 11.2	Voltage between Yellow phase & Blue phase:	Volt	
AII 11.3	Voltage between Blue phase & Red phase:	Volt	

AII 12.0	Typical Power supply phase voltages (phase to neutral voltages)		
AII 12.1	Voltage between Red phase & Neutral:	Volt	
AII 12.2	Voltage between Yellow phase & Neutral:	Volt	
AII 12.3	Voltage between Blue phase & Neutral:	Volt	
AII 13.0	Typical Power supply line Current/phase Current		
AII 13.1	<u>line Current/phase Current</u> Red phase	Amp	
AII 13.2	<u>line Current/phase Current</u> Yellow phase :	Amp	
AII 13.3	<u>line Current/phase Current</u> Blue phase :	Amp	
AII 13.4	<u>Neutral Current</u>	Amp	
AII 14.0	Power factor		

SECTION IV, A-Technical Specification FM Mono and Stereo Modulation Monitor including RF amplifier:

Technical Specification FM Mono and Stereo Modulation Monitor including RF amplifier:

4.0	One Set of FM Mono and Stereo Mod Monitor to be used in tandem with RF amplifier are to be quoted as per technical specification given below. FM modulation monitor; (i) Should provide standard deviation reference and zero deviation for SNR. (ii) Should provide MPX signal output.
------------	-----------------------------------------------------------------------------------------------------------------------------------------------------------------------------------------------------------------------------------------------------------------------------------------------

FM Mono and Stereo Modulation Monitor including RF amplifier:

S. No.	Parameter	Technical Specification	COMMENTS OF TENDERER WITH TECHNICAL DATA / SCHEMATIC DRAWINGS Nos
4.1	R.F. INPUT:		
4.1.1	Frequency range	88-108 MHz. [To be Tunable to any frequency in VHF FM band	

		88 MHz to 108 MHz] in steps of 100 KHz.	
4.1.2	RF Input Range	1 to 5 Vrms, 50 Ohm BNC	
4.1.3	Sensitivity	100 μ V or better.	
4.1.4	Accuracy at all modulation levels	\pm 2.0 %	
4.2	BASEBAND MEASUREMENTS:		
4.2.1	Modulation frequency	30 Hz - 100 KHz	
4.2.2	Frequency deviation (Nominal)	\pm 75 KHz for 100% modulation.	
4.2.3	Frequency deviation indication	0 to 150 %	
4.2.4	Frequency deviation indication accuracy	\pm 2.0 %	
4.2.5	AM noise measurement	To measure AM noise down to 70 dB from 100% AM modulation.	
4.2.6	MPX signal output :		
4.2.6(i)	Frequency response	Better than 0.25 dB	
4.2.6(ii)	Harmonic Distortion	Better than 0.01%	
4.2.6(iii)	IMD (SMPTE)	Better than 0.01%	
4.2.6(iv)	SNR	Better than 90 dB	
4.3	STEREO MEASUREMENTS:		
	It should have 2 semi peak modulation meters for simultaneous monitoring of L & R channels, total modulation and measurements of channel separation, cross talk, S.C. suppression, noise and pilot etc. It should be possible to feed in MPX signal separately.		
4.3.1	Channel separation (L/R or R/L)	Better than 90 dB, 30 Hz to 15 KHz	
4.3.2	Cross talk (L+R) to (L-R) or (L-R) to (L+R)	Better than 90 dB, 30 Hz to 15 KHz	
4.3.3	Pilot carrier measurement	0.50 %, 0% to 15 % injection	
4.3.4	Range indication	0- 100 dB, auto in 1 dB steps	
4.4	OUTPUT:		
4.4.1	Level (L & R)	+ 4 dBm, 600 ohms, balanced	
4.4.2	Frequency response	\pm 0.25 dB	
4.4.3	De-emphasis	50 μ s	
4.4.4	Signal to noise ratio	\geq 85 dB	
4.4.5	Harmonic distortion	\leq 0.01%	
4.4.6	Inter-modulation distortion (SMPTE)	\leq 0.01%	
4.5	POWER REQUIREMENTS		
		Single Phase as per Section 1.0	
4.6	GENERAL REQUIREMENTS:		

4.6.1	All RF input and power input cords with suitable connectors are to be provided.	
4.6.2	Instrument should be able to be mounted in a standard 19" rack.	
4.6.3	All accessories needed for various measurements to be quoted.	
4.7	ENVIRONMENTAL	As per Section 1.0
4.8	Dimensions (Approximate) (W x H x D):	To fit in 19" rack and dimension details to be given by tenderer.
4.9	Weight (Kg)	To be given by tenderer.

SECTION IV, B - TECHNICAL SPECIFICATION - 15 kW AIR COOLED DUMMY LOAD

4.8 **15 KW Dummy Load, 50 Ohm:** One no. 15 kW air cooled Dummy Load, 50 Ohm with thru line power meter etc. are to be quoted for transmitter as per technical specification given below including power meter , line section, 3-1/8" EIA flanges, for measuring forward (≤ 15 kW) & reflected (≤ 1.5 kW) power including all accessories , cables complete with Adaptor Kit.

4.9 **A thru line power meter** - to be used with 15 kW Dummy Load as above - for measuring forward & reflected power along with Transducers / Sensing elements are to be quoted as per technical specification given below .

15 KW DUMMY LOAD

S.No.	Description	Technical Specification
4.10	Power Rating	15 kW continuous
4.11	Connector	3-1/8" EIA Flange
4.12	Frequency Range	88 to 108 MHz
4.13	VSWR	$\leq 1.15:1$
4.14	Impedance (Nominal)	50 Ohm
4.15	Load Coolant	Air cooled
4.16	AC Power	Single Phase as per Part 1.0
4.17	Dimensions: (Length x Width x Depth)	To be given by the tenderer
4.18	Weight:	To be given by the tenderer

Thru line RF power meter

S.No.	Description	Technical Specification
-------	-------------	-------------------------

4.19	RF Power Meter Rectangular in housing with FORWARD & REFLECTED switch suitable for mounting in 19" rack including measuring elements, elements sockets and line section for connectivity with the rigid lines of size 3-1/8" complete as required. Forward Power : 15.0 kW Reflected Power: 1.5 kW	
4.20	Power Rating: Forward Power	15 kW continuous
4.21	Power Rating: Reflected Power	1.5 kW
4.22	Frequency Range	88 to 108 MHz
4.23	VSWR	≤ 1.1:1
4.24	Impedance	50 Ohm
4.25	AC Power	Single Phase as per part 1.0
4.26	Dimensions: (Length x Width x Depth)	To be given by the tenderer
4.27	Weight:	To be given by the tenderer

SECTION IV, C- TECHNICAL SPECIFICATION MOTORISED RF COAXIAL CHANGE OVER SWITCH

4.28 Motorized RF co-axial Changeover switch , Single Phase as per part 1.0 including control panel with port & matching flanges for connecting rigid line are to be quoted as per technical specification given below.

The switching will be carried out through above motorized RF coaxial relay / switch. The switch should have interlock for connecting with transmitter systems.

S.No.	Description	TECHNICAL SPECIFICATION
4.29	Connector	
4.29.1	Input and Out	3-1/8", EIA male
4.29.2	Termination/Dummy Load	3-1/8", EIA male
4.30	Frequency Range	88 to 108 MHz
4.31	Impedance	50 ohm
4.32	VSWR	≤ 1.1:1
4.33	Power Supply	Single Phase as per Part 1.0
4.34	Control Voltage	Single Phase as per part 1.0
4.35	Isolation	≥ 55 dB
4.36	Average Power Handling Capacity	≥ 15.0 kW
4.37	No. of Ports	4

4.38	Dimensions: (Length x Width x Depth)	To be given by the tenderer
4.39	Weight:	To be given by the tenderer

SECTION IV, D- SPECIFICATIONS FOR STEREO FM DIGITAL BROADCAST AUDIO PROCESSOR

GENERAL SPECIFICATIONS: Please refer Part 1.0.

(TECHNICAL SPECIFICATIONS)

STEREO FM DIGITAL AUDIO BROADCAST PROCESSOR

1.0 The Stereo FM Digital Broadcast Audio Processor should be based on Digital Signal Processing technique.

It should be able to provide multi band (minimum 5) compression, limiting and clipping, automatic wideband gain control.

The processor should have phase limiter to maximize audible transparency and should also have provision for stereo enhancement and high/low frequency enhancement.

The processor should have in-built feature of multiple user pre-set. The user pre-set should be stored in the memory and without any battery back up. By using the processor user pre-set, the factory pre-set of the Processor should not change.

2.0 The Stereo FM Digital Audio Broadcast processor should accept following inputs .

1. Digital AES / EBU inputs
2. Analogue left-right inputs
3. Sub-carrier inputs (Subsidiary Channel Authorization and Radio Data System/Radio Broadcast Data System)(SCA and RDS/RBDS)

2.1 The Stereo FM Digital Audio Broadcast processor should give following outputs.

1. Digital AES/EBU left-right output
2. Analogue left-right output
3. Composite stereo output/ multiplexed output.

2.2 Necessary function switches such as level/gain control etc. should be available on the front panel. All these control shall be rugged and reliable.

2.3 The processor should have visual monitoring of various technical parameters on the front panel. All the monitoring must be from front panel. In case a separate PC is required for control and operation of Stereo FM Digital Audio Broadcast processor the same must be quoted. The required computer should be of a reputed make and of latest configuration.

2.4 The equipment is to be properly earthed with the existing equipment earthing system in the transmitter container.

2.5 Radio Frequency Interference (RFI)/Electromagnetic Compatibility (EMC) filter shall be provided at mains input of the Stereo FM Digital Broadcast Audio Processor as per relevant standards for effective rejection of interference from high power VHF/UHF transmitters operating in near by places.

SPECIFICATION OF EQUIPMENT;

3.1	ANALOG AUDIO INPUT	
3.1.1	Configuration:	Stereo
3.1.2	Nominal Input Level:	Adjustable from -9.0 to +12.0 dBu .
3.1.3	Maximum Input Level:	+24 dBu
3.1.4	Connectors:	Two XLR-type, female, EMI-suppressed.
3.1.5	A/D Conversion :	Minimum, 24-bit

3.2	ANALOG AUDIO OUTPUT	
3.2.1	Configuration :	Stereo. Flat or pre-emphasised (at 50 μ s or 75 μ s), software-selectable.
3.2.2	Output Level(100% peak modulation):	Adjustable from -6 dBu to +20 dBu peak, into 600 Ω or greater load, software-adjustable.
3.2.3	Signal-to-noise: (20 Hz to 15 KHz)	\geq 80 dB unweighted
3.2.4	Distortion: (20 Hz to 15 KHz)	\leq 0.02 % THD.
3.2.5	Cross Talk (20 Hz to 15 KHz)	- 70 dB
3.2.6	Connectors:	Two XLR-type, male, EMI-suppressed.
3.2.7	D/A Conversion:	Minimum, 24-bit

3.3	DIGITAL AUDIO INPUT	
3.3.1	Configuration :	Stereo, AES/EBU standard, 24-bit resolution.
3.3.2	Sampling Rate :	32, 44.1 or 48 KHz automatically selected.
3.3.3	Connector :	XLR-type, female, EMI-suppressed.
3.3.4	Input reference level	Variable within the range of -25.0 to -10.0 dBFS
3.3.5	De-emphasis:	Software-selectable

3.4	DIGITAL AUDIO OUTPUT	
3.4.1	Configuration:	Stereo AES/EBU standard.
3.4.2	Sample Rate :	32, 44.1 or 48 KHz, selected in software
3.4.3	Connector :	XLR-type, male, EMI-suppressed.
3.4.4	Output Level(100% peak modulation) :	-20.0 to 0.0 dBFS, software-controlled.

3.5	COMPOSITE BASEBAND OUTPUT:	
3.5.1	Configuration :	Two outputs, with individual level controls.
3.5.2	Maximum Output Level:	+12.0 dBu
3.5.3	D/A Conversion:	Minimum, 24-bit
3.5.4	Signal-to-Noise Ratio: (20 Hz to 15 KHz)	≥ 85 dB.
3.5.5	Distortion : (20 Hz to 15 KHz)	$\leq 0.02\%$ THD.
3.5.6	Stereo Separation: At 100% modulation (30 Hz to 15 KHz)	>55dB.
3.5.7	Cross talk-Linear main channel to sub channel, or sub channel to main channel	-70 dB, main channel to sub channel, or sub channel to main channel
3.5.8	38 KHz Suppression:	≥ 70 dB.
3.5.9	Pilot Protection :	-60 dB relative to 9% pilot injection, ± 250 Hz
3.5.10	57 KHz (RDS)Protection:	-50 dB relative to 4% sub carrier injection, ± 1.0 KHz.
3.5.11	Connectors:	Two BNC, EMI suppressed.

3.6	REMOTE CONTROL INTERFACE (OPTIONAL)	
3.6.1	Configuration:	Eight (8) inputs, opto-isolated and floating
3.6.2	Voltage :	Details to be given by tenderer
3.6.3	Connector :	Suitable for 5.6.1 , EMI suppressed.
3.6.4	Control :	User-programmable for multiple user presets, factory presets, bypass, test tone, stereo or mono modes, analog input, digital input.

3.7	REMOTE COMPUTER INTERFACE (OPTIONAL)	
3.7.1	Configuration:	Transmission Control Protocol (TCP)/ Internet Protocol (IP) protocol via modem or Ethernet interface.
3.7.2	Connectors:	RS-232 , EMI-suppressed. Ethernet or Modem card supported with PCMCIA
3.8	POWER	
3.8.1	Voltage :	Single Phase as per Part 1.0
3.8.2	Connector :	IEC, EMI-suppressed. Detachable 3-wire power cord supplied.
3.8.3	Safety Standards :	ETL listed to UL standards, CE marked.

3.9	The The Stereo FM Digital Audio Broadcast processor shall essentially have the following :
3.9.1	<u>Protection against current over-loads</u> : The equipment should mute in case of overload and revert to normal functioning once overload ceases to exist.
3.9.2	<u>Protection against thermal overload</u> : Temperature of equipment inside component should be monitored and the equipment should get muted with a visual indication whenever temperature exceeds permissible limits. In case of excessive temperature of inside component, the equipment should be protected.
3.9.3	The equipment should have protection against open circuit, full short circuit, ultrasonic frequencies and high RF fields
3.9.4	It should be switchable to all operating modes as per Technical specification.
3.9.5	Necessary function switches such as level/gain control etc. should be available on front panel. These controls shall be rugged and reliable.
3.10	<u>ACCESSORIES</u> : All necessary accessories like connection cords and connectors shall be supplied along with the units. The standard accessories should be clearly mentioned in the tender. Also, optional accessories, if considered useful/recommended by the supplier, should be quoted separately with technical details.
3.11	The equipment shall be mounted in the 19” rack (Stereo Programme input - cum -- monitoring rack).
3.12	<u>Earthing</u> : An earth terminal shall be provided in the equipment body for connecting audio earth connection.
3.13	<u>SPARES(OPTIONAL)</u> : Essential and recommended spares components , PCBs, and modules shall be quoted separately including remote operation(optional) and telemetry(optional) .

2.2 SPECIFICATION FOR SUPPLY, ERECTION, TESTING AND COMMISSIONING (SETC) OF 16 PANEL VHF FM ANTENNA ALONG WITH ASSOCIATED EQUIPMENT, ITEMS & ACCESSORIES.

SECTION 1.0 TECHNICAL REQUIREMENT

S.No	Project	Tower Height in Mts.	16 Panel VHF FM Antenna	RF Co-axial Cable Length (M) *	Antenna Switch Frame / Panel	RF Coaxial Rigid lines & accessories required
1.	Naushera (Mangla Devi Fort)	150	1 No.	2x170M	1 No., 6 Port	Yes

* Exact length will be intimated at the time of placement of order.

SECTION 2.0

GENERAL SPECIFICATIONS: Please also refer Part 1.0.

1.0 SCOPE:

Supply, erection, Testing and commissioning (SETC) of {16 Panel VHF FM Antenna, RF Coaxial Cable, Antenna Switch Frame / Panel, RF Coaxial Rigid Lines & accessories at Naushera (Mangla Devi Fort) as per following Schematic Drawings:

Sl. No.	Drawing No.	Details
1..	TM-158998	Schematic Drg. for SETC of 16 Panel Antenna etc. at Naushera (Mangla Devi Fort)

The broad scope of above Supply, Erection, Testing and Commissioning (SETC) on FM Band-II Aperture are as follows:

1.11 16 Panel Four Bay VHF FM antenna as per Specification.

1.12 RF Coaxial cable as per Specification.

This will also include the Vertical & Horizontal RF Cable tray for dual feeder system.
3-1/8" RF Coaxial Cable at **Naushera (Mangla Devi Fort)**.

1.13 Antenna Switch Frame/Panel as per the specification. Refer Drawings as follows:

Drg. No. TM-15899 for Naushera (Mangla Devi Fort)

1.14 RF Coaxial Rigid Lines as per specification.

1.15 All components used, for 16 Panel FM Antenna, RF coaxial cable, Dehydrator, Antenna Switch Frame/Panel & RF Coaxial Rigid Line shall be of standard make & must be specified while quoting along with the printed datasheet from OEM.

2.0 INSPECTION: Please refer Part 3.0

3.0 COMPLETION OF SETC: Please refer Part 1.0

4.0 SUPPLY, ERECTION, TESTING AND COMMISSIONING :

The SETC {of 16 Panel VHF FM Antenna, RF Coaxial Cable, Dehydrator, Antenna Switch Frame / Panel, RF Coaxial Rigid Lines & accessories}, shall be undertaken by the Tenderer in accordance with ATP and in conformity with the AIR Specification.

4.1 SUPPLY: Supply of 16 Panel VHF FM Antenna, RF Coaxial Cable, Dehydrator, Antenna Switch Frame / Panel, RF Coaxial Rigid Lines, & accessories etc. shall be as per SECTION 5.0 of AIR Specification.

4.2 ERECTION: 16 Panel VHF FM Antenna, RF Coaxial Cable, Dehydrator, Antenna Switch Frame / Panel, RF Coaxial Rigid Lines, & Accessories (as per SECTION 5.0) will be done in the transmitter complex as per layout plan approved by AIR.

4.3 TESTING: 16 Panel VHF FM Antenna, RF Coaxial Cable, Dehydrator, Antenna Switch Frame / Panel, RF Coaxial Rigid Lines, with Accessories and associated equipment are to be tested after the erection, after making all the initial checks including physical inspection and continuity checks of wiring/cabling etc. as per drawings. Only after satisfying that erection is fit for testing (without the application of RF power), the testing will be taken up with RF power. The testing will be undertaken by the tenderer as per standard practice in conformity with ATP.

4.4 COMMISSIONING AT SITE: After erection and testing of the Antenna, performance figures/ measurement for all parameters are to be taken by the Tenderer in the presence of AIR's representative as per ATP.

Field strength survey at 1KM distance to be done & give to indenter. Field strength survey of actual 360° horizontal radiation pattern shall be carried out upto the threshold of 48 dBu in four directions at 90° to confirm pattern.

4.5 AMBIENT CONDITIONS FOR ALL IN DOOR EQUIPMENT: Please refer Part 1.0

4.6 ENVIRONMENTAL CONDITION FOR OUT DOOR EQUIPMENT& ITEMS

i	Maximum Wind Speed	198 km/Hour
ii	Temperature	0°C to 50 °C
iii	Humidity	95% non-condensing
iv	Snow fall & Rainfall	Moderate to heavy.

4.7 POWER SUPPLY FOR IN DOOR EQUIPMENT: Please refer Part 1.0

SECTION 3.0 TECHNICAL SPECIFICATIONS

3.1 16 PANEL TYPE VHF FM ANTENNA

Exact frequencies will be intimated at the time of placement of order.

3.1.1 INTRODUCTION:

3.1.2 The FM Antenna is required for use with FM transmitter of All India Radio. The Antenna will consist of 16 Panels (4x4).

3.1.3 Sites – Naushera (Mangla Devi Fort)

– Total 1 Place): Each face/side shall consist of 4 panels, which will be mounted on each of the four faces of the tower. Each panel **will consist of two horizontal dipoles and two vertical dipoles** in respect of these sites. No other offer will be acceptable to AIR.

3.1.5 The Power Feeding to the Antenna shall be through Antenna Patch Panel - for Splitting the RF power into two Equal parts for feeding Upper & Lower Antenna Panel Assembly. The Antenna Switch Frame /Panel shall also have arrangement for feeding full Out Put Power to either Upper or Lower Portion of Antenna Panel Assembly. The Antenna will be installed on existing self-supporting tower. The FM aperture of tower will be of square cross-section of about 2500 mm x 2500 mm with Latticed Steel Structure .The tower shall also be having VHF TV Antennae in Band – I / Band–III and UHF TV Antennae in Band–IV in addition to VHF FM Antenna in Band -II .

3.1.6 ELECTRICAL PARAMETERS:

- (i) Polarization : Circular.
- (ii) Input impedance : 50 Ω (ohm) unbalanced, each.
- (iii) Frequency Range : 88 -108 MHz.

(iv)

(a) VSWR : Better than **1.2:1.0** over the Operating full band (Frequency Range 88-108 MHz). To be optimized on operating frequency (to be intimated later at the time of placement of the order) better than 1.1:1.0 between 100 – 103.7 MHz

(b) VSWR & Return Loss (dB) Value in Graph form over entire (88 -108 MHz) frequency range to be enclosed.

3.1.7 Power Rating of Antenna, Loading Details & Input Connector Sizes: As per table given below:

Sl. No	Name of Site	Power Rating	Weight of Antenna in Kg.	Wind Load in Kg.	Vertical Antenna Aperture in mm	Max. Wind Speed in Km/H	Input Connector size
1	2	3	4	5	6	7	8
1.	Naushera (Mangla Devi Fort)	≥ 80 KW	≤ 3500	≤ 4500	≤12 000	198	2x3-1/8” EIA

3.1.7.1 Power Rating of Antenna, Loading Details & Input Connector Size: As per table as above. **No other Power Rating of Antenna, Loading Details & Input Connector size will be acceptable to AIR as the firm tender offers will be considered on equitable basis and any other tender offer is likely to be rejected.**

3.1.8 Downward beam tilt : Between [0.5 ° to 1°] for entire Operating Frequency Range

3.1.9 Null filling : Required, 10%.

3.1.10 **Antenna gain** (in dBd) ≥ 5 dBd - (Antenna gain in all directions over entire frequency range of (88 – 108) MHz should be enclosed with the tender)

3.1.11 a) No. of Vertical Panels : 4 Nos. (i.e. No. of Bays = 4)
{on each face of Square tower}

3.1.11 b) No of Panels per Bay : 4 Nos.

3.1.11 c) No of dipoles per Panels : 4 Nos. 2 horizontal & 2 vertical

No other antenna except as per 3.1.11(a to c) as above will be acceptable to AIR as the firm tender offers will be considered on equitable basis and tender offer is likely to be rejected.

3.1.12 **Spacing between panels:** Actual distance to be intimated in tender and a drawing showing profile Erection of panels also to be forwarded.

3.1.13 **Vertical Plane:** Expected Pattern for 0° to $\pm 90^\circ$ to be forwarded with tender.

3.1.13.1 **Horizontal plane:** Radiation pattern should be Omni directional. Measured gain variation in dBd should be enclosed with tender.

3.1.14 Antenna panels feeding arrangements (For two RF Coaxial cables): Antenna system shall be compatible for accepting RF power with **two RF Coaxial cables** and also to facilitate operation of half Antenna system i.e. either Upper or Lower half ---- under system fault or maintenance/ contingency requirement ---- from either of the two RF Coaxial cables.

Full details and detailed schematic drawings of the above proposed feeding system shall be submitted with tender by the Tenderer.

3.1.15 Full Performance Details: Detailed drawings and data sheets are to be forwarded with Tender for the following.

3.1.16 Actual measured Field Radiation Pattern, for V&H vectors separately, for a similar antenna supplied elsewhere.

3.1.17 Pressurization System : pressurization is must up to antenna dipoles i.e in the RF Coaxial cable, power dividers, sub dividers, splitter, branch RF Coaxial cables & sub-distributor RF Coaxial cables.

All the RF coaxial cables as above shall be air dielectric type. Foam type RF coaxial cables will not be accepted and tender is liable to be rejected.

3.1.18 MECHANICAL DETAILS : {For Entire Antenna Assembly}

(i) EXTERNAL MATERIAL : Panels/Dipoles will be made of stainless steel or hot dip galvanized steel or Marine Brass. Power Dividers & Rigid feed lines will be made of Marine Brass or Copper. End Connectors on Dipoles and Feed Cables will be of standard & reputable makes & their makes should be indicated in Tender. All electrical contacts must be silver plated. Reflector Panels & clamps shall be constructed of hot dip galvanized M.S. material Or light weight alloy/fiber reinforced materials. All fasteners will be of Stainless Steel or High Tensile non corrosive material.

(ii) INTERNAL MATERIAL: Inner lines of Dipoles will be of copper or Brass. All electrical contacts will be silver plated. All inners and bullets will be made of Beryllium copper and silver plated. Insulators will be made of high quality pure Teflon / PTFE.

(iii) All joints to be made completely air tight & water tight.

(iv) MOUNTING ARRANGEMENT : All the 16 panels will be fixed on vertical and horizontal supports to be provided by the tenderer on the four faces of Tower. These supports may be of hot dip galvanized angle iron rails. Technical details are to be forwarded by the Tenderer.

3.1.19 ACCESSORIES : Antenna supply will be complete with Power Dividers, Rigid Lines, RF Coaxial Distribution Feed Cables with matching End Connectors, Adaptors/ Reducers; Clamps & Fasteners for Dipoles, Power Dividers and Reflector Panels etc. Full details, list and schematic drawings of 16 Panel VHF FM Antenna & associated hardware system/ subsystem drawings to be forwarded with tender.

3.1.20 TECHNICAL DATA: Following technical details data and engineering drawings are to be submitted by the Tenderer, to assess to merit of the offer, without which tender will be considered incomplete & is liable to be rejected.

- (i) Complete information, details, parameters as mentioned in specification and information required for Fixing/ Mounting the various Fixtures /accessories for the SETC are to be submitted with tender by the Tenderer.
- (ii) Make, Model & Type of Rigid lines, Distribution Feed cables and Matching End Connectors as above should be given in tender.
- (iii) Photograph of the single dipole, single panel and complete 16 panel antenna system.
- (iv) Engineering drawing of single dipole, single panel and complete 16 panel antenna system along with dimensions.
- (v) Engineering drawing of single panel and complete 16 panel antenna system along with power dividers and RF coaxial air dielectric cables along with input and output end connector sizes & their power ratings of the dual feeder system.
- (vi) A write up giving working details and salient features of the Antenna system to be forwarded with tender.
- (vii) Power handling capacity of following components shall be submitted in the tender document by the Tenderer :
 - a) Main Power divider input and output end connector size & power rating (88-108 MHz).
 - b) Main RF air dielectric feed cables size & power rating including, input and output end connectors size & power rating (88-108 MHz).
 - c) 2nd Power divider input and output end connector size & power rating (88-108 MHz)
 - d) 2nd RF air dielectric feed cables size & power rating including input and output end connector size & power rating (88-108 MHz).
 - e) Similarly further as per design of manufacturer.

- f) Individual Dipoles including input end connector size & power rating (88-108 MHz)
- (viii) Insertion loss (dB) figure from input point to the end of Distribution Feed cable shall also be indicated.

3.1.21 Earthing Work: 4 Nos. of independent earth systems will be provided by the tenderer/ OEM as per IS. The value of the earth resistance of each earth system should be less than 1 Ohm.

3.1.22 Spares (**Optional**): List of recommended spares and any other accessories. (Items wise details of offered material including part numbers, if any are to be given by the tenderer). In case of kits, full item wise details of kits are to be provided.

The tenderer shall quote for one set of manufacturers recommended list of spares for Complete antenna system based on the actual failure pattern. These may include following:

- a) "O" ring
 - b) Silicon grease
 - c) Connectors assorted sizes
 - d) RF distributors air dielectric coaxial cables
 - e) Dipole
 - f) Other miscellaneous items.
- 3.1.23 Test set up facilities available at OEM works for antenna measurement: The details are to be submitted by the tenderer along with photo graphs of the test set up facilities at OEM works.

3.2 RF CO-AXIAL AIR DIELECTRIC CABLES & DEHYDRATOR

3.2.1 RF CO-AXIAL AIR DIELECTRIC DUAL FEEDER CABLE SYSTEM

- (i) Frequency Range: 88-108 MHz
- (ii) Impedance: 50 Ohm \pm 1 Ohm
- (iii) Other technical details given below:

Sl. No.	Name of Site	RF Coaxial air dielectric Feeder cable Length *	Average Power Rating of each RF Coaxial air dielectric Feeder cable at standard conditions VSWR 1.0, ambient temperature 40° C (At frequency 108MHz)	Attenuation of each RF Coaxial air dielectric Feeder cable at standard conditions VSWR 1.0, ambient temperature 24° C (At frequency 108 MHz in dB/100 M
(1)	(2)	(3)	(4)	(5)
1.	Naushera(Mangla Devi Fort)	2x170M	\geq 40 kW	\leq 0.50

* Exact length will be intimated at the time of placement of order.

3.2.2 The size of RF coaxial air dielectric cables shall be as per AIR Specification as mentioned in column 4 & 5 of clause 3.2.1(iii) failing which tender will be considered incomplete and is liable to be rejected.

However feeder cable length may be considered as tentative as given in SECTION 5.0 of AIR Specification.

3.2.3 All accessories associated with Feeder cable are to be provided as per the site requirement for completion of SETC i.e.

- (i) EIA flange connectors
- (ii) EIA flange Gas Pass connector
- (iii) EIA flange Gas Barrier connector
- (iv) Hoisting stockings
- (v) Earthing kits
- (vi) Wall gland
- (vii) Cable clamps with nut, bolt washer (adjustable height) and associated Accessories as per cable manufacturer's recommendations
- (viii) Any other accessories offered for the completeness of the system (Items wise details of offered and included material, items & part are to be given by the Tenderer)

3.2.4 Dehydrator with tubing & accessories for dual feed RF Coaxial cable system:--

For Pressurisation in entire RF Coaxial Cable and Antenna System

Qty - 2 Sets for each site.

S. No.	Technical Parameter	TECHNICAL SPECIFICATION
(i)	Dehydrator Type:	Automatic
(ii)	Operating Voltage:	Single Phase as Section 2.0
(iii)	Output Capacity (SCFM)	≥ 0.3
(iv)	Ambient Humidity % maximum:	95%
(v)	Dry air storage tank capacity	Details to be given by the tenderer
(vi)	Output pressure (adjustable)	Details to be given by the tenderer
(vii)	Low pressure alarm(adjustable)	Details to be given by the tenderer
(viii)	Pumping Power Consumption :	Details to be given by the tenderer
(ix)	Compressor Rating:	Details to be given by the tenderer
(x)	Low Pressure Alarm:	Details to be given by the tenderer
(xi)	Dimensions, H x W x D, mm :	Details to be given by the tenderer
(xii)	Net Weight (kg):	Details to be given by the tenderer

3.3 ANTENNA SWITCH FRAME/PANEL

3.3.1 ANTENNA SWITCH FRAME / PANEL (Suggestive Schematic Drawing No. **TM-15999** Antenna Switch Frame / Panel with Mimic Diagram, Power Meters {for Forward & Reflected Power Readings at inputs and outputs ports} shall have the provision for connecting the Combined Transmitters Power to either a split Antenna System or complete Antenna through manual patching facilities.

3.3.1.1 Frequency Range: 88-108 MHz

3.3.1.2 Other Technical Details:

Sl. No	Name of Site	No. of Ports	Return Loss	Insertion Loss	Average Power Handling Capacity	Input Connector	Output Connector
1.	Naushera(Mangla Devi Fort)	6 Ports	Better than 30 dB	<0.1 dB	30 kW	3-1/8" EIA	2x3-1/8" EIA

3.3.1.3 Mechanical Details: Dimensions and weight to be given by the tenderer.

3.3.1.4 Provision to connect with the transmitter interlocks should be provided.

3.3.1.5 Technical data/details: The following technical data/details are to be provided by the tenderer to assess the merit of the offer without which tender will be considered incomplete & is liable to be rejected. The tenderer should make a detailed offer.

(i) The Antenna Patch Panel/Switch Frame: The Unit shall be designed to connect combined RF output of FM VHF(Band -II)Transmitter to split antenna system for equal power, outputs to each antenna half.

(ii) Manual patching facilities for use during maintenance or emergency conditions shall be provided by the tenderer. The Patch Panel shall also have arrangement for directly connecting the Transmitters to upper and lower half of antenna. For reference a suggestive Antenna patch panel mimic diagram is enclosed.

(iii) Power Monitoring Unit with meter: Antenna Switch Frame / Panel Power Meters shall have the provision for Forward & Reflected Power Monitoring Unit with meter at inputs and outputs ports i.e. separate Power Monitoring Unit with meters at the input and at both the output ports individually for forward & reflected power. The metering should be clearly shown as above in the technical details.

(iv)Return Loss (dB) Graphs: for Antenna Switch Frame/ Patch Panel shall be submitted by the Tenderer for entire VHF frequency range.

(v) Insertion loss figures (dB): for entire VHF frequency range are required to be given by the tenderer.

3.4 RF COAXIAL COPPER RIGID LINES & ACCESSORIES :

3.4.1 Technical parameters/specification of Copper RF Coaxial Rigid Lines (50 Ohm) and accessories.

Sl. No.	Name of Site	Size	Average Power Rating at standard conditions VSWR 1.0, ambient temperature 40° C	Attenuation at standard conditions VSWR 1.0, ambient temperature 20° C (At frequency 108 MHz in dB/100 M)	Frequency Range
1.	Naushera(Mangla Devi Fort)	3-1/8"	≥ 45 kW	≤0.35 dB	88-108 MHz

3.4.2 Additional Hardware and accessories (Impedance 50 Ohm): Copper RF Coaxial Rigid Lines (50 Ohm) and accessories.

For Site: Naushera (Mangla Devi Fort) – 1 place: as per Section 5.0

4.0 INSPECTION: Please also refer Part 3.0:

ANNEXURE-I: INSPECTION DETAILS

The inspection for acceptance of the Complete Antenna System will be carried out at the Tenderer's system Integrators works in accordance with Acceptance Test Procedure/Protocol (ATP). All facilities like complete set of measuring instruments, power supply, manual assistance, etc. will be provided by the supplier. Complete details and specifications of the Complete Antenna System will be checked and all parameter values will be measured.

All other equipment will be accepted on the basis of Original Equipment Manufacture's (OEM) Test Certificates (as per AIR Specification) duly signed and stamped on the letter head of the OEM, failing which Original Equipment Manufacture's (OEM) Test Certificates will be considered incomplete and equipment offered by the firm is liable to be rejected.

The associated /auxiliary equipment & accessories i.e. equipment/items at SECTION 5.1 Clause 5.2 (S. no. 2.1 to 2.14) , (S. no. 3.0), (S. no. 4.0), (S. no. 5.0), (S. no. 6.0), (S. no.7.0)& (S. no. 5.8) will be accepted on the basis of Original equipment manufacturer's test certificate (OEM's) and received at site by ultimate consignee, in good condition.

The complete Acceptance Test Procedure/Protocol (ATP) will be prepared by the manufacturer

and submitted to Director Engineering (Proj.), P&D Unit, DG: AIR for approval. This Procedure after modification (if required during the process of approval) shall form the basis for Performance / Inspection Tests to be carried out. ATP will also indicate full details of set up for measuring / testing equipment to be deployed during the Performance Measurement/ Inspection Test at factory.

Testing and measurements of the Complete Antenna System will be carried out at any three frequencies in the VHF band, 88 to 108 MHz. Complete set of instruments will be made available in advance and the list of these measuring instruments along with their set ups may be forwarded along with the Tender. Tenderer shall arrange for the photographs of Complete Antenna System which will be attached with the ATP/Inspection report.

Exhaustive checking and measurements will be carried out so as to completely check the compliance of the Complete Antenna System with the requirements as projected in the specifications.

It is mandatory that all these testing and measurements of Complete Antenna System as per parameters in Section 3.0 at any three frequencies in the VHF band, 88 to 108 MHz, are carried out well in advance. These must also be submitted to All India Radio along with the call for inspection of Transmitter well in advance for analyzing etc. These measurements details, graphical printout notes and figures must be available, at the integrator's works at the time of inspection.

Following information should also form part of above data which will also be checked for Complete Antenna System during inspection by indenter's representative for Complete Antenna System 16 panel VHF FM Antenna, RF Coaxial Cable, Antenna switch panel/frame, RF Coaxial Rigid Lines & Accessories at Tenderer's system Integrator works :-

- a) Main Power divider input and output end connector size & power rating (88-108 MHz).
- b) Main RF air dielectric feed cables size & power rating including input and output end connectors' size & power rating (88-108 MHz).
- c) 2nd Power divider input and output end connector size & power rating (88-108 MHz)
- d) 2nd RF air dielectric feed cables size & power rating including input and output end connectors' size & power rating (88-108 MHz).
- e) Similarly further as per design of manufacturer.
- f) Individual Dipoles including input end connector size & power rating (88-108 MHz)
- g) Country of origin make, model, serial number of all equipment/items

Section: 5.0: Please refer part 1.0.

2.3 SETC OF PROGRAMME RECEIVING/ FEED FACILITY

(A) RN TERMINAL – C BAND

(B) DTH -KU BAND

(C) EMERGENCY TRANSMISSION FACILITY

SPECIFICATION FOR C-BAND RN TERMINAL

1.0 For General specification: please Part 1.0

1. INTRODUCTION:

AIR uses Satellite Radio networking through INSAT series of Satellites.

A RN Receive Terminal has to be provided along with the containerized transmitter to act as ground terminal to receive C-Band transmissions through satellite for feeding them to the transmitter.

Section below give details of the scope and specification of these Receive terminals. The Networking through satellite is in SCPC mode. Details of the networking & INSAT system parameters are also furnished to enable tenderers to design & offer appropriate system compatible with the existing setup.

2. CONFIGURATION OF THE COMPLETE C BAND SYSTEM :

Schedule of Items to be supplied against this configuration is as follows:

MANDATORY ITEMS-

Sl. No	Equipment	Qty.	Sub Para
2.1	6 Meter Parabolic Dish Antenna along with Earthing System, Lightning arrestor, feed and accessories including cable tray	1 set	7.1,7.2
2.2	a) LNBC C-Band	3 nos	7.3
	b) 50M length Low loss cable with connectors---	2Nos	7.4
	c) L band line amplifier	3Nos.	7.5
2.3	L-Band Digital Receiver	4 nos.	7.6
2.4	Full size wired rack(42U) with jack strip and tag block	1 Nos.	
2.5	Stereo Monitoring Amplifier with a set of speakers	1nos.	7.7
2.6	L band 1:2 divider(2 no.) & L band 1:4 divider(2nos.) along with other accessories like connectors and integration material	1 set	
2.9	Lap top	1 No	
2.10	Installation, testing and Commissioning of	1 Job	

	the System at site		
2.11	Inspection as per approved ATP	1 Job	
2.12	OPTIONAL ITEMS- 2 days training	1 Job	
2.13	Low loss cable Per meter length (to be quoted separately)	1 Job	

3. SCOPE

- 3.1 The scope of this tender includes supply of the equipment as per specifications, technical requirements and quantities as detailed in the tender, installation of the equipment at site, acceptance testing as per Acceptance Test Procedure (ATP) and commissioning of equipment at site. Charges for installation, testing and commissioning are to be quoted separately.
- 3.2 The AIR will provide the necessary space for the installation of the equipment, layout of the cable and location of the parabolic dish antenna etc.
- 3.3 After acceptance of the tender, the tenderer should also provide detailed plans of supply of material, installation, testing as per ATP and commissioning.
- 3.4 The tenderer shall ensure that the equipment offered fully incorporate the standard features for safety and protection including shielding from EMI.
- 3.5 Exhaustive checking and measurement will be carried out to check the complete compliance of the RN Receive terminal with the requirements projected in the AIR specifications. The measurements must be submitted to ALL India Radio in advance. The measurement details must be available at the tenderer's works at the time of inspection.

4. LOCATION FOR INSTALLATION OF RN TERMINAL :

These RN Receive terminals will be installed at the location as per suggestive site lay out plan. The tenderer firm may quote separately for the installation, testing and commissioning as mentioned above.

5. SYSTEM PARAMETERS & COMPATIBILITY :

The system parameters of AIR's Radio Net-working system and INSAT system details are enclosed as Annexure - 'C'. While quoting for the RN Terminals, the tenderer may refer to these details to ensure conformity to the existing uplink system. Then tenderer should also check up system design and link budget to ensure satisfactory operation and trouble free service of the equipment set up when installed.

6. GUARANTEE & RELIABILITY :

Please refer Part 1.0

- 6.1 The equipment offered should be capable of continuous round the clock operation.

- 6.2 It should be based on industry standard and state of art technology.

7. TECHNICAL SPECIFICATION FOR DIGITAL RECEIVE TERMINAL

The Digital Receive terminal should conform to the following technical specifications.

7.1. Specification for 6 M C- BAND PDA

Electrical Specification:

- | | | |
|----|------------------------------|------------------------------------------------------------------------------------------------------------------------------------|
| 1) | Diameter | Diameter should be 6 Meter (nominal) should meet the technical requirements mentioned below. |
| 2) | Frequency Range | 3.7-4.2 GHz |
| 3) | Receive gain at 4GHz | ≥46 db |
| 4) | Receive G/T | Better than 24.5 db/ K |
| 5) | Pointing Accuracy | Better than ±0.25° |
| 6) | Side Lobe Level/GAIN pattern | As per ITU-RS-580-V or its latest amendment. |
| 7) | Tracking mode | Manual (motorized may be quoted as optional). The Antenna should have calibrated marking for Elevation & Azimuth angle indication. |

Mechanical Specification:

SI No	Parameter	Specification
1	Reflector Structure:	The reflector should be made of perforated aluminum sheet mounted as panels/segments over reflector supporting structure. The reflector supporting structure should be made from aluminum or steel tubes/angles and mounted over trusses emanating from the central hub.
	i) Reflector Material:	Perforated Aluminum sheet with thickness of at least 2.0mm
	ii) Coated with:	Non metallic anti corrosive paint to avoid concentration of heat at focal point (mention the paint used)
	iii) Reflector supporting structure:	Should be made from Aluminum /Steel material. It should be coated with anti corrosive paint
2	Antenna Stand:	
	Mount:	Kingpost
	Material:	Heavy duty, made with hot dip Galvanized steel and coated with anti corrosive paint.
4	Steerability:	
	Elevation:	15° to 85°
	Azimuthal:	≥ ± 55°(continuous, without change of mount position)

5. For wind load please refer part 1.0

6. For Environmental please refer part 1.0

Note: The tenderer will provide foundation of antenna as per drawing and recommendation of Original equipment Manufacturer. Two number of proper earth pits will have to be provided for earthing the lightning arrestor of antenna. The earth resistance should be as per IS amended upto date.

7.1 Deicing System for 6 meter PDA:

Offered Deicing system should have following features:

- i) Deicing system should be of heating element type.
- ii) Heating element of appropriate length has to be fixed on ground facing side of reflector panel.
- iii) At least half of total number of reflector panels has to be fitted with heating element.
- iv) Deicing system should maintain reflector surface temperature at above 5°C.
- v) System should be shock proof and proper insulation has to be provided to eliminate fault current. Appropriate rated RCCB's has to be provided for tripping whenever heating element shorts to Antenna reflector panels.
- vi) Deicing system has to be provided with thermostat for facilitating auto regulation of the Deicing system.
- vii) Deicing system has to be provided with circuit breaker for switching ON and OFF of the system manually.
- viii) Pilot lamp indicators have to be provided for indicating functioning of the De-icing system.
- ix) Number of heating elements used in the offered deicing and total power requirement of the offered system should be indicated clearly. Spare heating element for deicing kit shall be offered by the tenderer.

7.2 DETAILS OF THE FEED

- i) Type of Mounting Prime Focus. The provision for adjustment of feed from ground it self should be made. It should have calibrated polarization angle indication and adjustable smoothly for optimization.
- ii) Ports Two (Orthogonal)
- iii) Polarization Linear (adjustable, $\pm 90^\circ$)
- iv) Freq. Range 3.7 - 4.2 GHz
- vi) Return loss at Centre freq. ≥ 17 dB
- vii) Connector Wave-guide WR 229 G Flange
- viii) Cross-Polarization discrimination ≥ 30 dB

Note : Feed of C-Band antenna would be two port (orthogonal). One LNBC would be mounted over each port. At a time only one LNBC output would be connected to the input of power divider. The other

LNBC mounted over orthogonal port will serve as cold stand by. The arrangement should be provided so that by rotating the feed by 90°, the standby LNBC could be brought into circuit

7.3 Professional grade C- BAND L.N.B.C.

a)	Input frequency	3700 – 4200 MHz
b)	Input impedance	50 Ω
c)	Input connector	WR 229 G Flange
d)	Output frequency	950 - 1450 MHz
e)	L.O. Stability	PLL, better than ± 2 PPM
f)	Noise temperature	≤ 35°K
g)	Conversion gain	≥ 55 dB
h)	Phase Noise 1 KHz 100 KHz	-60 dBc/Hz -80 dBc/Hz
i)	Output impedance & Connector	75 Ω ; F (Female)
j)	Power supply	+ 15 V to + 24 V through output connector

7.4 Cable

Good quality professional grade cable with connectors at both ends shall be quoted with following specifications

- i) Cable attenuation (with F connectors at both ends) ≤ 3.5 dB/100 feet at 1500 MHz
- ii) Impedance 75 Ω

7.5 L BAND LINE AMPLIFIER

1.	Frequency of operation	950 - 1450 MHz
2.	Input level	- 80 dBm to -50 dBm
3.	Input and Output Impedances	75 Ω
5.	Noise figure (Typical)	≤ 10 dB
6.	Gain	≥20dB
7.	Gain flatness (Over entire band)	± 2 dB
8.	Operating voltage (Through centre conductor of the RF cable)	15V to 24 VDC

Features :

- a) Capable of handling voltage required for LNBC.
- b) Provision for wall mount installation

7.6 DIGITAL RECEIVER with L band input. The digital receiver should conform to the standard and specification of existing digital radio networking system. It should be possible to control /set receiver through front panel as well as through lap top.

- i) Input
 - a) Freq. Range 950 - 1450 MHz
 - b) Freq. Step size Resolution \leq 25 KHz Local (remote control optional)
 - c) Impedance 75 Ω
 - d) Level \leq -25 to -70 dBm
- ii) Demodulation QPSK
- iii) Channel Change time \leq 1sec.
- iv) FEC decoding (a)Rate $\frac{1}{2}, \frac{3}{4}$ Viterbi (b) Rate 1/2 sequential-decoding (Selectable Rate preferred)
- v) Audio coding ISO/MPEG-I/Layer-2
- vi) Data rates (Selectable) 64, 128, 192 & 256, 384 kbps (QPSK)
- vii) Modes Mono, Dual mono & stereo
- viii) Audio output
 - a) Impedance \leq 600 Ω
 - b) Level (Maximum) + 12 dBu (adjustable)
 - c) T.H.D. (at 1 KHz) @ 256kbps \leq 0.2% (at +8 dbu output)
 - d) Audio signal bandwidth 20 Hz to 20 KHz
 - e) Frequency response \pm 1.0 dB (20 Hz to 20 KHz)@ 0 dBu o/p
 - f) Signal to Noise ratio \geq 75 dB (256 kbps, Eb/No \geq 9 dB,+12dBu)
 - g) Dynamic range \geq 80 dB
 - h) Cross-talk ratio \geq 75 dB wrt +12dBu input in encoder.
 - i) Audio output channels Two mono/one stereo
 - j) Digital Audio output AES / EBU STANDARD (Professional)
- ix) Eb/No Threshold \leq 5.5 dB(QPSK)
- x) B.E.R. Immunity at 1x 10E -5 for no subjective loss in quality
128kbps,QPSK,Vit $\frac{1}{2}$ at Eb/No 5.5 dB
- xi) Audio Sampling Rate 48 KHz (24,32,44.1khz optional)
- xii) Auxillary data channel
 - a) Data rate \geq 4.8 Kbps
 - b) Interface RS – 232

8.6 The tender/offer should include following details :

- (i) Apart from printed technical data/specs of this equipment, Block schematic of the sub-system, including the photograph etc. should be attached with the offer.
- (ii) A complete schedule of equipment, accessories and option etc. should also be appended with the tender.

8.7 List of essential spares giving quantities and cost may also be given alongwith the offer.

8.8 Maintenance support in terms of spare units/components be ensured for atleast 10 years.

AIR - RN SYSTEM PARAMETERS

Type of Receive Terminals

C-Band	Size	6.0 M
	Polarization	Linear H/V
System Characteristic:		
	Mode	SCPC
	RN Channel bandwidth	350 Khz (Digital 256kbps)

CXC-Band Transponder

Uplink Freq. Band	5925 - 6425
Downlink Freq, Band	3700 - 4200
Sat. EIRP	38 dBw
S.f.d.	-85 dBw/ m ²
Polarization	
Uplink	Linear H/V
Downlink	Linear V/H

Digital chain parameter

Modulation	QPSK
FEC	½,Seq./Viterbi decoding
Baseband	20Hz-20KHz
Baseband compression	ISO,MPEG-I,Layer-II
Modes	Mono,Dual Mono, Stereo, Voice/Data
	Channel
Bit rate	256 kbps

2.3 SETC OF PROGRAMME RECEIVING/FEED FACILITY

2.3 [B] SETC Specification of DTH KU Band

Professional IRD Specifications For Ku-Band

The IRD should have a front panel display and one should be able to enter or edit all the parameters for a perfect reception of the signals. A test output for video (BNC), as well as stereo audio should be available at the front panel. There should be provision for observing the BER (Pre & Post correction) of the signal and signal level in the front panel. IRD should be able to descramble BISS mode 1 and BISS-E signals. IRD should have at least 20 memory setups to store channels. IRD should have CI slot so that by inserting the CAM modules signals can be descrambled.

1. RF Parameter Specifications-

S. No.	Parameter	Specification
1.1	Input Frequency Range	950 - 1750 MHz
1.2	No. of Inputs	2 nos.
1.3	Tuning Step Size	125 kHz, maximum
1.4	Satellite Frequency Band	Ku-Band
1.5	Input Impedance	75 Ohms
1.6	Input Connector	F-Type female
1.7	Input Power Range	-30 to -65 dBm per carrier
1.8	Image Rejection	>30 dB
1.9	Input Return Loss	7 dB, minimum
1.10	Noise Figure	20 dB, maximum
1.11	AFC Tuning Range	± 5 MHz
1.12	De-Modulation Method	QPSK demodulation
1.13	Variable Symbol Rates	1.5 to 40 M Symbol/sec
1.14	Convolution Inner FEC Rates selectable	R= 1/2, 2/3, 3/4, 5/6, 7/8, (for QPSK)
1.15	IF Filter Bandwidth	Automatic Selection (dependent on Symbol Rate)

2. Audio and Video Decompression Parameters

S. No.	Parameter	Specification
2.1	Video Resolution (all resolutions shall be capable of I, P & B frame decoding)	720 x 576, 704 x 576, 544 x 576, 480 x 576, 352 x 576, 352 x 288 (other standard resolutions should be selectable)
2.2	Video Decompression Type	MP @ ML
2.3	Television Standard	PAL-B
2.4	Audio Decompression Type	MPEG-layer-2 (Stereo/Musicam, i.e. Single Mono, Dual Mono, Stereo, and Joint Stereo)

3. Transport Stream O/P: MPEG-2 ASI on BNC

4. Video Output Specifications

4.1.1 Analog Video Output Specifications

S. No.	Parameter	Specification
(a)	Connector Type	BNC (75 Ohms)
(b)	Quantity	2 Nos. of analog composite PAL-B CCIR Standard (one main and one for monitoring)
(c)	Level	1.0 V p-p +/- 5%

4.1.2 Digital Video Output Specifications

S. No.	Parameter	Specification
(a)	Connector Type	BNC (75 Ohms)
(b)	Quantity	2 Nos. of DIGITAL output compliant to ITU-R BT.656 Standard
(c)	Level	800mV p-p for SDI

4.2 Video Performance Specifications

S. No.	Parameter	Specification
(a)	Frequency Response	Within 2 dB down at 5 MHz
(b)	Chroma-Luma Delay	±30 ns, maximum

(c)	Field Time Distortion	< 2%
(d)	Line Time Distortion	< 1%
(e)	Short Time distortion	< 2%
(f)	Differential Gain	< 4%
(g)	Differential Phase	< 2°
(h)	Signal to Noise Ratio	>55 dB (luminance weighted)

5. Audio Output

5.1 Analog Audio

Each analog audio output shall be presented as a stereo pair. In the event of “Mono” transmissions, the same encoder input channel will be output to both left and right connectors. In other modes (“Stereo”, “Joint Stereo” and “Dual Mono”), the two encoder input channels will be output as left and right. **Means shall be provided to combine the left and right channels on the IRD output to produce a mono output from stereo transmissions to accommodate those sites not equipped for stereo transmission.**

5.1.1 Analog Audio Output Specifications

S. No.	Parameter	Specification
(a)	Output Impedance	600Ω (balanced)
(b)	Number of Outputs	4, configurable as Stereo, Joint Stereo, Single mono, Dual mono.
(c)	Connector Type	XLR Male Socket (ie: no terminal block)

5.2 Digital Audio Output Specifications

S. No.	Parameter	Specification
(a)	Output level	5 Volts nominal
(b)	Output Format	AES/EBU
(c)	Load Impedance	110 Ohms
(d)	Connector Type	XLR Male Socket
(e)	Number of Outputs	2, Stereo Channels

5.2.1 Audio Performance Specifications at 256 Kbps and sampling rate of 48 KHz

S. No.	Parameter	Specification
(a)	Peak Output Level	+ 18 dBm into 600Ω balanced
(b)	Clipping Level	S/W Selectable to be provided

(c)	Sampling Rates	32, 44.1 and 48 KHz
(d)	Frequency Response	40 Hz to 20 kHz \pm 2 dB
(e)	THD	<0.3 % at 1 kHz
(f)	Dynamic range	80 dB (ITU-R/Arm weighting)
(g)	Crosstalk at 1 kHz	60 dB, full scale (20 Hz to 20 kHz)
(h)	Output level adjustment	\pm 6 dB minimum

6. LNB Power Supply & Control

S. No.	Parameter	Specification
(a)	LNB Voltage	\pm 13 V (Vertical)/ 18 V (Horz) polarization switching.
(b)	Power Consumption	400 mA. (Max.)
(c)	Over Current protection	Fold back current limiting.
(d)	LNB Power Supply & Control	Receive Polarization Control by electrical Command Via LNB-IF feeder (High & Low band switching Pulse for Ku Band operation).

7. Size

Mount: 19" rack mountable.

Specification for the motorized Feed of Ku- band

Focus : Prime/offset focus,
 Frequency : Ku- band
 Ports : 2 port, for receiving both linear and Orthogonal polarization signals
 Polarization discrimination : 30 dB (min)
 Polarization Adjustment : -5degree to 95 degree

Specifications for Cables & Connectors

An interconnecting low loss cable of length of 75 meters the cable should be quoted in denomination of 50m & 25m, which can be used independently (i.e. as 50m or 25m) or collectively i.e. as a 75m length using a coupler (I-Connector) in between the 50m & 25m cables] between outdoor and indoor units. The total insertion Loss for cable should not exceed 15dB at 1450 MHz. Two sets of cables are to be quoted.

1. Specifications for Parabolic Dish Antenna, solid type, 2.4 M (dia)

S. No.	Parameter	Specification
(a)	Antenna type	Offset / Prime Focus
(b)	Frequency	10.7 GHz to 12.75 GHz
(c)	Size	2.4 m diameter
(d)	3dB beam width	Better than 1°
(e)	Aperture efficiency	Better than 70%
(f)	Gain at 11.7 GHz	Better than 47 dB (min)
(g)	Drive system steerability	Manual
(h)	Azimuth	0 to 360° continuous with fine adjustments
(i)	Elevation	10 deg to 85 deg
(j)	Feed	Prime focus, 2 port, for receiving both linear orthogonal polarized signal.
(k)	Polarization	Linear orthogonal
(l)	Mount option	Pole Az-EI and Pole wall to be quoted separately. Mount should be powder coated/ hot dip galvanized.
(m)	Reflector Material	Glass fiber reinforced polyester
(n)	Feed Impedance	50 ohms
(o)	Feed VSWR	better than 1.5 : 1
(p)	Wind loading	80 Km/h operational, 200 Km/h survival

2. Notes:

2.1 The structural analysis may be provided from structural engineer to assess the strength.

2.2 A calibrated graduation of Azimuth, Elevation and Polarization offset should be provided in the antenna.

1. Specification for the Digital LNBC in Ku band

S. No.	Parameter	Specification
a)	Input frequency range	10.95 GHz to 11.7 GHz 11.7 GHz to 12.2 GHz
b)	Local Oscillator frequency	LO freq of LNBC should be capable to provide output frequency of LNBC between 950 to 2150MHz.
c)	L.O. Stability L.O. Phase noise	± 100 KHz or better Better than 75 dBc/Hz @ 1kHz
d)	Output frequency	950 MHz to 1450 MHz
e)	Conversion gain	60 dB Typical
f)	Gain response	Better than ± 0.5 dB/27 MHz
g)	Output level at 1dB compression point	3 dBm
h)	Output Connector	F type female
i)	Input VSWR/Output VSWR	Better than 2:1
j)	Noise Figure	Better than 1dB
k)	Power supply requirement	Should work between + 15V to +24V with current consumption of about 200 MA
l)	Input flange	WR 75
m)	Lightening / Surge protection	Should be provided

2. LNBC should be environmentally sealed against weather conditions and extremes of temperature (-30°C to 40 °C). LNBC should also be 100% water proof.

2.3(C) EMERGENCY TRANSMISSION FACILITIES

SECTION - I

General Specifications: Please refer Part 1.0

2.3. (C) .1 SPECIFICATION OF PROFESSIONAL CD PLAYER

Professional grade CD Players shall have the following Specification:

1. GENERAL FEATURES

- 1.1 Front loading of CD with soft eject mechanism
- 1.2 Auto Cue of the track
- 1.3 Fast cue within a track
- 1.4 Fader-start facility with indication
- 1.5 Provision to enable or disable the fader start
- 1.6 Display of current status, TOC (table of contents), elapsed time and remaining time
- 1.7 Disc error indication
- 1.8 It shall support CD_Rs as well as CD_RWs.
- 1.9 Tenderers shall quote Professional CD Player of one and only one make & model, failing which tender will be considered incomplete and is liable to be rejected.

2.0 TECHNICAL SPECIFICATION

SNo.	Technical Parameter	Specification
2.1	Line Outputs	
2.1.1	Analogue	Balanced Stereo L & R outputs on XLR Con.
2.1.2	Digital	AES/EBU format on 3 pin XLR Connector
2.2	Headphone Monitor Output	Stereo with level control
2.3	Line Output Level (Analogue)	
	Nominal	+4 dBu with built-in level control
	Maximum	≥ +18 dBu
2.4	Monitor Output level	≥ 20 mW
2.5	Analogue Line Output Impedance	≤ 150 ohms
2.6	THD+N	≤ 0.01% at max. specified output
2.7	Frequency Response	Within ± 1.0 dB over 20Hz to 20 KHz
2.8	Signal to Noise Ratio	≥ 95 dB (A-wtd.) at nominal output level
2.9	unbalance Channel	≤ 0.5 dB
2.10	Inter-channel Crosstalk	≥ 90 dB
2.11	Sampling Frequency	44.1 KHz
2.12	D/A Conversion	≥16 bit

2.13	Mounting	19" Rack Mount or Table mount
2.14	Connectivity	Details to be given by tenderer
2.15	Power Supply:	Single Phase as per section -I

2.3. (C) 2. SPECIFICATION FOR DYNAMIC MICROPHONE (CARDIOID)

1. GENERAL

This specification briefly describes the electro-acoustical and physical requirements of a high quality dynamic microphone suitable for use inside broadcasting studios, The microphone shall have sturdy construction and shall withstand temperature and humid conditions prevailing in tropical zones without deterioration in quality.

1.1 Tenderers shall quote Dynamic microphone of one and only one make & model, failing which tender will be considered incomplete and is liable to be rejected.

2. FREQUENCY RESPONSE

The frequency response shall be within ± 3 dB over a range of 150 Hz to 12 kHz and having presence going up to maximum of 8 dB peak with reference to 1 kHz in the high frequency range starting from approximately 3 kHz to 10 kHz. BASS roll-off giving roughly 8 to 10 dB attenuation at 50 Hz shall be available.

3. DIRECTIONAL CHARACTERISTICS

3.1 The microphone shall have cardioid/super cardioid pattern over frequency range of 250 Hz to 4kHz.

3.2 Typical polar diagrams at different frequencies shall be supplied with the tender,

4. FRONT TO BACK RATIO

The front to back ratio shall be at least 10 dB from 250 to 4 kHz along vertical axis.

5. SENSITIVITY

The sensitivity shall be equal to or better than 2.4 mV/Pa (-52.4 dBV -reference 0 dBV =1 volt/Pa)

6. OUTPUT IMPEDANCE

Not more than 600 ohm,

7. HUM PICKUP

In a 50 Hz A.C. field of 0.001 Gauss, the hum pickup by the microphone shall not exceed -130 dBV. (reference 0 dBV = 1 volt).

8. DISTORTION

The total harmonic distortion shall not exceed 1% at SPL at 120 dB at 1 kHz.

9. WEIGHT

25th October, 2010

Net weight of the microphone, without cable, shall be less than or equal to 350 gms.

10. VIBRATION ISOLATION

The microphone shall have shock proof mounting to reduce mass related or "SEISMIC" type vibrations without compromising its acoustic properties.

11. ACCESSORIES

11.1 Standard accessories manufactured by original manufacturer of the microphone like carrying case, stand adapter and gold plated mating connectors (a pair of male and female) shall be supplied along with the microphone.

11.2 Adaptors, accessories and stands suited for the microphones and not included as standard accessories shall be quoted separately as additional items and shall be accompanied by illustrative leaflets.

12. TESTS

Each microphone shall be accompanied with its test data sheet incorporating sensitivity, polar pattern, frequency response etc. from the manufacturer.

13. ENVIRONMENTAL CONDITIONS

The microphone shall be suitable for operation as per clause 15.0 of section –I.

14. Inspection: As per Part 1.0

15. Guarantee: As per Part 1.0

2.4 SETC of Stereo & Digital Programme Input cum Monitoring rack

Section 1.0: Please refer Part 1.0.

SECTION 2.0 TECHNICAL SPECIFICATIONS

1.0 The Stereo & Digital Programme Input-Cum-Monitoring Rack should be suitable for:

- i) Feeding stereo programmes to VHF FM transmitters;
- ii) Feeding Digital input/programmes to VHF FM transmitters;
- iii) Metering and monitoring of different programme inputs as per (i) and (ii) as above as well as signal at intermediate points in the audio chain and also detected signals.

Detailed specifications of rack and individual equipment are given below.

2.0 GENERAL AND BRIEF DESCRIPTION OF REQUIREMENT:

2.1 Suggestive block schematic (Drg. no. TM-16003) of the Stereo & Digital Programme Input-Cum-Monitoring Rack is enclosed for reference. However tenderer is required to provide complete equipment schematic diagram, wiring diagram and other technical details of the offered Stereo & Digital Programme Input-Cum-Monitoring Rack.

2.2 All audio lines from the Jacks & Equipment are to be connected to a terminal block to be located near the bottom of the rack for external feeding of cables by the indenter. All the equipment are to be properly earthed with the existing equipment earthing system in the transmitter hall.

2.3 RFI/EMI filter shall be provided at mains input of the Stereo & Digital Programme Input-Cum-Monitoring Rack as per relevant standard provisions for effective rejection of the interference from the high power transmitters operating in the premises.

These Stereo & Digital Programme Input-Cum-Monitoring Rack will be used in High Power Transmitter halls (upto 250 KW transmitter RF output power) i.e. the rack with full complement of equipment as to operate in a high RF field. As such all the specifications of the individual equipment as well as the full chain, are to remain valid in high RF fields.

2.4 The main Rack will be used to install various equipment as per in Schedule of material /requirement for supply (unpriced). The rack will be of standards 19"equipment width size. The frame of the rack shall be of high quality extruded aluminum or high grade steel material as per IS code amended up to date. The aluminum profiles shall be either anodized or powder coated and the steel parts shall give pleasing and aesthetic look and superior and long lasting paint finish. The rack is to be of sturdy design. The thickness of main frame section shall be greater than or equal to 1.6 mm and for covers greater than or equal to 1.2mm.

The final equipment lay out and Jack wiring drawing is required to be submitted by the tenderer and got approved from the Indenter after the placement of Supply Order.

2.5 The rack shall be fitted with jack strips [2 nos jack strip for analogue and 2 nos.

Jack strip for digital] as per specification. Separate jack strips shall be provided for digital and stereo inputs.

2.6 Blank panels for above rack shall be supplied for coverage of blank space in the racks.

2.7 Other requirements/ features.

i)	AC main power supply	Single phase as per section 1.0.
ii)	Ambient conditions	Single phase as per section 1.0.
iii)	Protection against RF	The equipment is to be provided with adequate interference shielding so as to perform satisfactory operation in the transmitter hall which houses other high power medium wave or FM transmitters.
iv)	Accessories	The equipment shall be supplied complete with all mating connectors, input output cords and power supply cords. Lamps and cooling fans are to be fixed in the rack.

v)	The rack is to be supplied complete with all cabling/wiring/connectors.	
vi)	The equipment shall be completely modular in design for easy maintenance and replacement. Photographs showing exterior and interior of each equipment to be forwarded with tender.	
vii)	Spares: Essential and recommended spares components shall be quoted separately based on failure pattern. a) Cooling fan b) Any other item as per recommendation of Manufacture	
viii)	Earthing & RF Shielding: An earth terminal shall be provided in the rack body for connecting audio earth connection. RF Shielding shall be provided by the tenderer.	
ix)	The following equipment will also be installed in this rack in addition to equipment/items mentioned in Schedule of material /requirement for supply. (un-priced): Broadcast Processor (2 nos.), Mod monitor & Tone generator.	
x)	<u>AC POWER SUPPLY DISTRIBUTION:</u> The power supply distribution is to be provided with an MCB in the incoming circuit near bottom of rack. Necessary RF filter is to be provided. The entire system is to operate on single phase supply. 5/15 Amps. 3 pin sockets are to be provided at different levels for various equipment.	
xi)	<u>DC SUPPLY (OPTIONAL):</u> In case any of the Rack equipment is to operate on a separate DC Supply , one such unit is to be offered as spare and price are to be quoted separately as optional	

3.0 TECHNICAL SPECIFICATIONS

3.1 STEREO MODE:

25th October, 2010

i)	Input	6 nos. active balanced for L & R separately
ii)	Level Nominal	- 6 to 6 dBu (adjustable in steps of 1.0 dB)
	Level Maximum	+20 dBu
iii)	Input Impedance	600 ohms, balanced & floating or higher than 10K ohm
iv)	Output at selection	4 no., L & R balanced & floating
v)	Nominal Level	+ 6 dBu
vi)	Distortion (30 Hz to 20 KHz)	Better than 0.1%
vii)	Impedance	600 ohm balanced or less than 50 ohm
viii)	Frequency response (30 Hz to 20 KHz)	Better than +/- 0.5 dB
ix)	Inter Channel Cross talk at 15 KHz between any two unrelated channels.	Better than 70 dB
x)	Phase difference, L/R	Better than 3 degrees
xi)	S/N (rms) unweighted (30 Hz to 20 KHz)	Better than 80 dB

3.2 DIGITAL MODE :

i)	Configuration :	Stereo AES/EBU standard, 24-bit resolution.
ii)	Sampling Rate :	32, 44.1 or 48 KHz automatically selected.
iii)	Connector :	XLR-type, female, EMI-suppressed.
iv)	Input reference level	Variable within the range of -20.0 to 0.0 dBFS

4.0 Stereo & Digital input selector (BALANCED)

(Solid State based):

Different STEREO & DIGITAL programme inputs dual selector (Solid State based) will be available at input of the rack. The above selector shall select one of these programmes at the output. Selected position will be indicated by LED's/bar graph.

4.1 STEREO INPUT SELECTOR (Solid State based):

Technical Parameters

i)	Number of stereo inputs	6 nos with XLR connectors
ii)	Output requirement	4 nos , XLR connector
iii)	Selection	By push buttons with solid state or relay switching, with memory.
iv)	Indication by	LED's
v)	Input/Output Isolation	90 dB
vi)	Output/ Input Isolation	90 dB
vii)	Frequency response (30 Hz to 20 KHz)	Better than +/- 0.5 dB

viii)	Distortion (30 Hz to 20 KHz)	Better than 0.1%
ix)	S/N (rms) unweighted (30 Hz to 20 KHz)	Better than 80 dB

4.2 Digital INPUT SELECTOR (Solid State based):

Different Digital programme inputs selector (Solid State based) will be available at input of the rack. The above selector shall select one of these programmes at 4 independent outputs. Selected position will be indicated by LED's/ self illuminated switch.

Technical Parameters:

i)	Configuration :	Stereo AES/EBU standard, 24-bit resolution.
ii)	Number of Digital inputs	5nos. with XLR connectors
iii)	Output requirement	4 no. with XLR connector
iv)	Sampling Rate :	32, 44.1 or 48 KHz automatically selected.
v)	Selection	By push buttons with solid state or relay switching, with memory.
vi)	Indication by	LED's/ Bargraph
vii)	Impedance	110 Ohm

5.0 Metering & Monitoring selector for STEREO & DIGITAL INPUT (Solid State based):

5.1 Metering Selector: This selector is to be used for selecting any one of the Digital & Stereo inputs for the purpose of metering. Selected position is to be indicated by LED display/bar graph. Necessary D/A solid-state converters are to be included and provided by the tenderer

5.1.1 Stereo Mode:

i)	Number of Input	1 no ,XLR connector
iii)	Selection	By push buttons for stereo or digital mode
iv)	Indication by	LED Display

5.1.2 Digital Mode:

i)	Configuration :	Stereo AES/EBU standard, 24-bit resolution.
ii)	Number of Input	1 no ,XLR connector
iii)	Selection	By push buttons for stereo or digital mode
iv)	Indication by	LED Display

5.2 Monitoring Selector: This selector is to be used for selecting any one of the Digital & Stereo inputs for the purpose of monitoring. Selected position is to be indicated by LED display/bar graph. Necessary D/A solidstate converters are to be included and provided by the tenderer.

5.2.1 Stereo Mode:

i)	Number of Inputs	2 nos ,XLR connector
ii)	Selected Output	1no, XLR connector
iii)	Selection	By switch

5.2.2 Digital Mode:

i)	Configuration :	Stereo AES/EBU standard, 24-bit resolution.
ii)	Number of Inputs	1 no ,XLR connector
iii)	Selected Output	1no, XLR connector

6.0 PRECISION, INSTRUMENT QUALITY, STEREO DISPLAY UNIT:

The levels of selected signals are to be indicated on L&R bar graphs. Indication should be by suitable bargraph meter. Selection should not load the circuit.

6.1	Indication by	LED bar graph minimum of 20 elements, in three colours.
6.2	Value	Peaks, with selector switch
6.3	Measuring range	-20 to 24 dBu switchable pad/pads may be provided to change the reference level of bar graph as the maximum level to be displayed is +24 dBu.
6.4	Resolution	Better than 2 dBu in the range -20 to 0 dBu & 1 dBu in range 0 dBu to +24 dBu.
6.5	Frequency response	Better than +/- 0.1 dBu (30 Hz to 20 KHz)

7.0 STEREO & DIGITAL MONITORING AMPLIFIER

The monitoring amplifier is to be provided for monitoring of programme as selected by the selector switch and will be provided with a set of 2 high quality speakers for L/R channels.

7.1 SPECIFICATION FOR 40 WATTS STEREO & DIGITAL MONITORING AMPLIFIER:

7.1.1 GENERAL:

This specifications pertains to professional STEREO & DIGITAL monitoring amplifier for use in transmitters centers.

The amplifier shall be able to deliver an output of 40 Watt RMS and 200 Watt Peak Music Power Out put (PMPO) per channel with both channels driven at 1 Khz at nominal input level.

The amplifier shall be capable of continuous operation round the clock without degradation in

performance. Amplifier will operate on AC main single phase power supply as per section 1.0.	
7.1.2 <u>Technical</u> :	
The amplifier shall essentially have the following features:	
7.1.2.1	<u>Protection against current over-loads</u> : The amplifier should mute in case of overload and revert to normal functioning once overload ceases to exist.
7.1.2.2	<u>Protection against thermal overload</u> : Temperature of power pack and heat sinks of both channels should be monitored and the amplifier should get muted with a visual indication whenever temperature exceeds permissible limits. In case of excessive temperature of heat sinks, the amplifier should be protected by fuse blow up or by any other suitable measures.
7.1.2.3	Monitoring amplifier output should be continuously monitored for DC components or very low frequency components which might endanger speakers if present for longer durations. Amplifier output should get blocked in such an eventuality.
7.1.2.4	The amplifier should have protection against open circuit, full short circuit, ultrasonic frequencies and high RF fields
7.1.2.5	It should be switchable to stereo and dual mono operating modes.
7.1.2.6	Necessary function switches such as volume/gain control, low and high filters should be available on front panel. These controls shall be rugged and reliable.

7.1.3	INPUTS :	
7.1.3.1	No. of inputs (stereo)	1 no. (30 Hz to 15 KHz)
7.1.3.2	Input level	-10 dBu to +10 dBu for rated output
7.1.3.3	Input impedance	Better than 10K Ohms (balanced)
7.1.3.4	CMRR(20 Hz - 20 KHz)	Better than 60 dB

7.1.4	OUTPUT:	
7.1.4.1	Power output	40 Watt RMS at 8 Ohms nominal impedance at suitable terminals.
7.1.4.2	Frequency Response with reference to 1 KHz over the entire range (40 Hz to 15 KHz.)	Better than +/- 0.5 dB
7.1.4.3	Total Harmonic Distortion at 1 KHz.	Better than 0.25% at rated output
7.1.4.4	Signal to Noise Ratio With input shorted and at rated output unweighted rms) at 0 dBu input. (20 Hz - 20 KHz)	Better than 80 dB
7.1.4.5	Damping Factor	Better than 75 into 8 ohm at < 1 KHz.
7.1.4.6	Level difference between the Channels	Equal to or less than 0.5 dB
7.1.4.7	Phase difference	Better than 20 degree , (40 Hz to 15 KHz.)

	between the Channels	
7.1.4.8	Inter Channel Cross talk at 15 KHz	Better than 70 dB at nominal level.

7.1.5	DIGITAL AUDIO INPUT	
7.1.5.1	Configuration :	Stereo AES/EBU standard, 24-bit resolution.
7.1.5.2	Sampling Rate :	32, 44.1 or 48 KHz automatically selected.
7.1.5.3	Connector :	XLR-type, female, EMI-suppressed.
7.1.5.4	Input reference level	Variable within the range of -20.0 to 0 dBFS

7.1.6	<u>MECHANICAL:</u> The amplifier should be 19” rack mounting type for mounting in a rack.
-------	----------------------------------------------------------------------------------------------

8.0	SPECIFICATION FOR STEREO LOUDSPEAKERS SYSTEM
8.1	<u>GENERAL:</u> The loudspeakers system shall be high fidelity two way speaker system based on state of the art technology. The enclosure of the speaker shall be of rugged structure and of attractive design. The front grill attached to the enclosure shall be attractively designed, acoustically transparent and shall be fixed rigidly so that it does not vibrate. The tender should submit typical plots of Impedance vs Frequency, Amplitude vs Frequency, Phase vs frequency and Polar pattern.
8.2	<u>TECHNICAL SPECIFICATIONS:</u>
8.2.1	<u>POWER HANDLING CAPACITY:</u> The power handling capacity of each speaker should not be less than continuous RMS : 100 Watts (for each channel)
8.2.2	<u>Frequency Response:</u> The speaker system should have frequency response within ± 3 dB between 45 Hz to 20 KHz with respect to 1 KHz. The frequency response curve shall be submitted with tender and shall be supplied with each unit.
8.2.3	<u>Over load Protection:</u> The speaker should be protected against momentary peak overloads upto 6 dB above rated power handling capacity.

- 8.2.4 Nominal Impedance:
Nominal Impedance of 8 Ohms shall be offered. An impedance Vs. frequency plot shall be submitted with tender and shall be supplied with each unit.
- 8.2.5 Sensitivity : At 1 watt input (2.8 Volts across 8 ohm), each speaker system shall produce SPL of 90 dB or more at a distance of 1 M on axis.
Distance of apparent acoustic source behind front surface shall be specified.
- 8.2.6 Directivity: The Q - factor of the speaker system shall be specified . Polar response of the speaker system shall be supplied for both horizontal and vertical plane in each unit.
- 8.2.7 Matching:
The two loudspeakers shall conform to the above requirements and shall be a matched pair as regards their sensitivity, frequency response, phase response and polar pattern.
- 8.2.8 Phase Response : The system should behave as a frequency independent time delay. Phase Vs. frequency response curve shall be submitted with tender.
- 8.2.9 Dimensions, finish and weight of the speaker shall be specified by the tenderer.
- 8.2.10 Accessories: Matching transformer as required shall be supplied with the unit.

9.0 STUDIO HEADPHONES:

- 9.1. GENERAL: The headphone shall be designed to reproduce full audio spectrum faithfully (without any colouration) for quality monitoring in broadcast studios. It shall be light weight in construction and shall have provision for stereo/mono monitoring. Left and right ear-pieces shall be matched to reproduce stereo images correctly. The provision shall exist for parallel wiring of the left and right systems for mono monitoring.
- 9.2. ELECTRICAL REQUIREMENTS:
- The headphone shall conform to the following electrical requirements:
- | | | |
|-------|----------------------|-------------------------------------------------------------------------------------------------------------------------------------------------|
| 9.2.1 | Frequency range | The headphone shall reproduce faithfully a range of 40 - 16000 Hz. A typical frequency response curve shall be submitted along with the tender. |
| 9.2.2 | Electrical impedance | 2 x 600 ohms \pm 10% |

9.2.3	Sensitivity at 1 KHz	90 dB SPL for 1 mw input.
9.2.4	Max-power handling capacity	200 mw.
9.2.5	Total harmonic distortion	≤ 1% at max. permissible input level.

9.3. MECHANICAL REQUIREMENTS:

The diaphragm may be made of hard polyvinyl chloride or similar material and housed in polystyrene housing. The ear cushions shall be circumaural and may have foam filled material. The headphone shall be comfortable for extended use.

The headphone shall further conform to the following mechanical requirements:

- 9.3.1 The headstrap shall be made of spring steel wire encased in or supported by leather or flexible plastic and the length shall be adjustable.
- 9.3.2 Average pressure on ears : Max 4 N
- 9.3.3 Cord of at least 1.6 m length shall be provided. The cord may be detachable.
- 9.3.4 Standard stereo/mono phone plug 6.35 mm dia shall be provided as required.
- 9.3.5 Weight of the headphone without cord shall not exceed 250 grams.

10.0 STEREO AF JACK STRIP PANELS:

STEREO AF JACK STRIP PANELS:

10.1 GENERAL DESCRIPTION:

The stereo audio jack strip panels shall be used for stereo audio patching and termination in Broadcast Studios. The jack strip shall be of 2U height containing 20 jacks in each of two rows (one for left and other for right signal). The jack strip shall be suitable for mounting on standard 19” equipment rack. There shall be provision for fixing of removable legend strip with plastic cover on top/bottom of the jacks. The jack strip shall be wired with twin core shielded audio cable conforming to AIR specification.

All inner and outer contacts of jacks shall be wired to the tag block. Inter connections shall be made at the tag black .

The length of audio cable bunch shall be such that the jack strips can be mounted at a height of 1500 mm or below for full size racks through proper routing of cable bunch. The wiring bunches shall be neatly laid and clamped to the body of the

rack with adequate flexibility affording pulling of jack strip outside the rack on its front without strain on cables for attending to jack wiring. The wires shall be suitably marked with ferrules on both ends for easy identification.

10.2 JACK STRIP SPECIFICATION:

Jack Panel : General purpose black phenolic resin
Frame : Plated, steel or aluminum
End Bracket and side Strip : Cold rolled plated steel or aluminum
Designation Channel : On top/bottom of jack strip
Marking Strip : White plastic, matt finish
Marking Strip Cover : Clear extruded plastic
No. of Jacks in each row : 20, placed at equal distance centre to centre

10.3 JACK CONSTRUCTION:

The jack shall have rugged steel frame, press welded with copper alloy corrosion resistant springs. The contact shall be of welded crossbar palladium/gold for providing reliable, low resistance and long life contact. The jack shall be 20 point jack providing break on both wires and an isolated offset earthing lug. The jacks shall have solder tinned lug terminals. Make type and technical details and drawings of jacks are to be supplied with the tender.

10.3.1 TECHNICAL SPECIFICATION OF JACKS:

(i) Electrical:

- (a) Contact Resistance : 0.05 ohms maximum
- (b) Insulation Resistance : 1000 mega ohms min.
- (c) Dielectric withstanding : 500 VRMS AC voltage

(ii) Mechanical:

- (a) Bushings : Plated copper alloy bushings to accept standard 6.35 mm/
0.25 inch dia plug
- (b) Insertion Force : 7 lb (3.17 kg) maximum
- (c) Withdrawal Force: 1.5 lb (0.679 kg) minimum
- (d) Life : Min. 20,000 insertion/withdrawal cycles
- (e) Vertical Spacing : 0.625 \pm 0.01 inch centre to centre between jacks for stereo

11.0 STEREO AF PATCH CORDS

STEREO AF PATCH CORDS:

Two jacks will be joined together to form Stereo Set. Colour of Jacks/Sleeves and audio cables will be different to indicate L/R clearly.

11.1 PATCH CORDS WITH MATCHING PLUGS:

These shall be supplied in lengths of 3' and 6' with 6.35 mm/0.25 inch dia twin plugs at both ends of the patch cord. Individual plugs will have tip, ring and sleeve construction with complete continuity of thermoplastic insulation between plug elements. Two of these plugs are to be placed into handles to provide a twin-plug at each end of the patch cord. The two are electrically independent 3 conductor plugs spaced 0.625 inch centre to centre, with self-alignment feature. The plugs shall be made of Nickel-plated brass with black Bakelite molded cover.

The patch cord shall be made of 14/68 standard copper wire covered with insulating material with 98% tinned copper braided shielding and black thermoplastic outer braid woven over insulated conductors and shield. Make, type, origin and technical specification of patch cords are to be submitted along with the tender.

12.0 RF CONNECTOR:

RF CONNECTOR:

4 nos. of RF adopters are also to be provided. These are to be used for feeding RF power to Demodulators or Analyzer. These connectors are to be of BNC type.

13.0 DISTRIBUTION AMPLIFIERS:

The analogue stereo and digital distribution amplifier will be used for feeding a analogue stereo and digital programme to various destinations.

The analogue stereo distribution amplifier should be solid state audio amplifier having one stereo input and 4 separate individually adjustable stereo outputs.

The digital distribution amplifier should be solid state having one digital input and 4 separate digital outputs.

13.1 Analogue Stereo distribution amplifier:

1. **INPUT IMPEDANCE**
Input impedance shall be ≥ 10 k ohm (balanced).
2. **INPUT LEVEL**
(a) Nominal : 0 dBu
(b) Maximum : +20 dBu
3. **GAIN**
Shall have adjustable gain of ± 5 dB with respect to nominal setting.
4. **OUTPUT LEVEL**
(a) Nominal : 0 dBu
(b) Maximum : +20 dBu

5. **OUTPUT IMPEDANCE**
Output impedance shall be ≤ 50 ohm (balanced).
6. **FREQUENCY RESPONSE**
 ± 0.5 dB in frequency range of 40 Hz to 20 kHz.
7. **TOTAL HARMONIC DISTORTION**
Less than 0.1% at nominal level (1 kHz) and less than 0.5% at maximum output level. (Terminated into a load of 600 ohm) throughout the audio frequency range of 40 Hz to 20 kHz.
8. **SIGNAL TO NOISE RATIO AT NOMINAL INPUT/OUTPUT, RMS UNWEIGHTED (22 Hz-22kHz)**
 ≥ 90 dB
9. **INTER OUTPUT LOADING**
 - (a) If one of the outputs gets short circuited, the level on the rest of the outputs shall not fall by more than 0.3 dB.
 - (b) If two of the outputs got short circuited, the level on each of the remaining outputs shall not fall by more than 0.6 dB.
10. **INTER-CHANNEL PHASE DIFFERENCE**
Not more than 5 degree in frequency range of 125 Hz to 10 kHz and 10 degree from 40 Hz to 20 kHz.
11. **INTER-CHANNEL LEVEL DIFFERENCE**
Within ± 0.5 dB, from 40 Hz to 20 kHz.
12. **INTER-CHANNEL CROSS TALK**
Equal to or better than 60 dB at 20 kHz at nominal level.
13. **INPUT/OUTPUT CONNECTORS**
Input and all outputs shall be on 3-pin XLR connectors.

13.2 Digital distribution amplifier:

	DIGITAL AUDIO INPUT	
i	Configuration :	Stereo AES/EBU standard, 24-bit resolution.
ii	Sampling Rate :	32, 44.1 or 48 KHz automatically selected.

iii	Connector :	XLR-type, female, EMI-suppressed.
iv	Input reference level	Variable within the range of -20 to 0 dBFS

	DIGITAL AUDIO OUTPUT	
i	Configuration:	Stereo AES/EBU standard.
ii	Sample Rate :	32, 44.1 or 48 KHz, selected in software
iii	Connector :	XLR-type, male, EMI-suppressed.
iv	Impedance	110 Ohm

14.0 AUDIO WIRING:

AUDIO WIRING: All audio wiring will be carried out with high quality 2 core shielded Teflon multi strand tinned copper Audio Cable. Technical details of the offered audio cable is required to be enclosed with tender by the tenderer.

14.1. GENERAL DESCRIPTION:

This cable is required for wiring of jack strips in audio equipment racks in Broadcast Studios/Transmitting stations.

14.2. CORES:

Two cores, twisted. Each core conductor to be formed of 7 strands of 0.193 mm dia (36 SWG) annealed tinned copper wire conforming to IS 8130/1976 or higher number of strands of thinner gauge to give equivalent core cross section for better flexibility.

14.3. CORE INSULATION:

Each core conductor shall have PVC insulation of minimum radial thickness of 0.3 mm, conforming to type I of IS 5831/1970. The cores shall be color coded black and red or any other distinguishing color code.

14.4. FINISH AND SHIELDING:

The two cores shall be twisted together so as to give circular cross section to the cable for maximum flexibility. The shielding shall consist of about 80 strands of minimum 40 SWG annealed tinned copper wires closely woven in groups of 4-6 strands to give at least 98% coverage.

14.5. SHEATH:

The sheath over the shielding shall be of PVC of nominal thickness of 0.3 mm conforming to type 6 of IS 5831/1970.

14.6. OVERALL DIMENSION:

The outer diameter of the cable shall be 3.5 mm or less.

INSPECTION: Please refer Part 3.0.

2.5 SPECIFICATION OF MEASURING EQUIPMENT

2.5.1 SPECIFICATION OF AUDIO ANALYZER COMPLETE WITH ALL ACCESSORIES

GENERAL

1. SALIENT FEATURES:

1.0 The audio analyzer should incorporate latest state of art technology for checking up the performance of high quality VHF FM Transmitters and studio centers of AIR.

1.1 The audio generator and the analyzer should be an integral part of the equipment. The equipment should be fully solid state, self contained, compact, easy to set up, simple to use, rugged for using continuously for 24x7 hrs. basis.

1.2 The equipment should have operationally convenient grouped keys for carrying out fast measurements.

1.3 It should include "self-test" facility also.

1.4 The equipment should have auto ranging, scaling, nulling and sweep facilities etc.

1.5 The equipment shall have USB interface, PC & Printer connectivity to acquire data and measurements from the instrument.

1.6 The analyzer shall have complete dual domain test (generation and analysis) facilities.

1.7 It shall provide two channel audio analogue input /output as well as simultaneous digital input/ output in the AES/EBU (balanced) and consumer (coaxial as well as optical) formats.

1.8 The analyzer should have independent built-in analogue generators for two channels and independent built-in analyzers for two channels.

1.9 Digital interface stimulus and measurement capability to verify different specifications of AES/EBU Audio format shall also be available.

1.10 Audio parameters of the digital signal shall be measured in digital domain and not by converting it into analogue signal.

1.11 The analyzer shall have facility for audio monitoring through built -in speaker and/or stereo headphone jack with volume control.

2.0 Measurement capabilities: shall include the following:

2.1 ANALOGUE AUDIO

Amplitude, Noise (band pass, low pass, high pass and weighted filters), Level, Frequency, Phase, THD+N, Cross-talk/ separation, Inter modulation Distortion, Wow & Flutter (as an option). Swept measurements shall be possible with frequency and amplitude sweeps. Provision of De-emphasis filters and graphs of sweep measurements in real time on built in high contrast LCD display shall be available.

2.2 DIGITAL AUDIO

Analysis of digital audio signal in real time mode for measurement of audio signal content (band pass, high pass, AES 17 Low Pass and weighted filters), digital interface

characteristics (pulse amplitude, sample rate, bit activity, word width, delay between signals and jitter amplitude) monitoring and setting of non-audio bits.

3.0 SPECIFICATION OF EQUIPMENT

3.1 ANALOG SIGNAL GENERATOR

The Generator shall have the capability to generate Sine Wave, Square Wave and IMD (SMPTE) test signal.

3.1.1 General

- (i) No. of analog outputs: 2 independent outputs (Transformer coupled)
- (ii) Source Impedance: 600 Ohms, 150 Ohms or 200 Ohms
(User selectable)
- (iii) Output channel Separation: < -100 dB (20 Hz to 20 kHz)

3.1.2 Sine wave

- (i) Frequency range: 20 Hz – 100 kHz
- (ii) Frequency accuracy: Within ± 0.5 %
- (iii) Frequency resolution: 0.1% or better
- (iv) Amplitude Range (20 Hz - 20 kHz) : < -70 dBu to + 24 dBu (balanced)
- (v) Amplitude Resolution: better than 0.5 dB
- (vi) Amplitude accuracy: Within ± 0.2 dB
- (vii) Flatness: Within ± 0.05 dB (20 Hz to 20 kHz)
- (viii) Residual (a) THD: ≤ 0.05 % (20 Hz – 20 KHz)
(b)⁺Noise: better than -100dB (20 Hz – 20 KHz)
- (ix) Frequency & Amplitude Selection Control:
It shall be possible to select frequency in steps of x1, x10 and x100 with fine control. Amplitude selection should have coarse & fine control.
- (x) Frequency & Amplitude range of sweep:

It shall be possible to select the number of steps from 5 to 30. It shall be possible to vary the amplitude in steps of 1 dB to 10 dB.

3.1.3 Square wave

- (i) Frequency range: 20 Hz – 20 kHz
- (ii) Rise time: ≤ 0.5 micro second
- (iii) Amplitude range: -70 dBu to +24 dBu (balanced)

3.1.4 Inter-modulation distortion signal (SMPTE)

- (i) Frequencies: 60 Hz & 7 kHz in 4:1 ratio (LF: HF).
- (ii) IMD residual Distortion: ≤ 0.02 %

3.2 ANALOGUE AUDIO ANALYZER

- (i) Analog section of the analyzer shall be able to measure frequency response, phase, signal-to-noise ratio, crosstalk, absolute level, level ratio, total harmonic distortion plus noise, Intermodulation distortion and Wow & Flutter.
(as an option)

3.2.1 General

- (i) No. of input channels: 2
- (ii) Input Impedance: Nominally 100 k Ohms
- (iii) Terminations: 600 Ohm
(Selectable)
- (iv) Maximum input voltage: 100 Vrms (DC to 20 kHz), overload protected
- (v) Minimum input signal for measurement: -20dBu
(Other than wideband amplitude/Noise/level)
- (vi) CMRR: ≥ 70 dB at -20 dBu from 50 Hz to 20 kHz

3.2.2 Frequency measurement

- (i) Range: 20 Hz - 100 kHz
- (ii) Accuracy: Within ± 0.01 %
- (iii) Resolution: 5 digits

3.2.3 Wideband Amplitude/Noise measurement

- (i) Units: dBu
- (ii) Amplitude range: -105 dBu to +30 dBu at 1 kHz
- (iii) Amplitude Accuracy at 1 kHz: Within ± 0.2 dB
- (iv) Response Flatness: Within ± 0.05 dB, 20 Hz to 20 kHz
- (v) Residual Noise: -115 dBu, 22 Hz to 22 kHz BW.
- (vi) Filters: 22 Hz to 22 kHz audio band pass, 400Hz high pass, 30 kHz and 80 kHz low-pass and CCIR QPK weighting.

3.2.4 Level measurement

- (i) Units: Volts, dBu (0.775Vref.) and dBV (1V ref.)
(Selectable)
- (ii) Range: 10 mV to 100 V for specified accuracy and flatness (-38 dBu to + 42 dBu)
- (iii) Accuracy (1 kHz ref.): ± 0.1 dB, 20 Hz to 20 kHz
- (iv) Response Flatness (1 kHz ref.): Within ± 0.05 dB, 20 Hz to 20 kHz

3.2.5 Crosstalk measurement

- (i) Frequency range: 20 Hz to 20 kHz
- (ii) Crosstalk measurement range: -110 dBu to 0 dBu
- (iii) Crosstalk accuracy: Within ± 0.5 dB

3.2.6 Total Harmonic distortion + Noise measurement

- (i) Units: % and dB
- (ii) Fundamental Range: 20 Hz to 20 kHz
- (iii) Measurement range: 0.01 % to 100 % full scale
- (iv) Residual (a) THD: ≤ 0.05 % (20 Hz to 20 kHz)
(b) ⁺Noise: better than -100dB (20 Hz to 20 kHz)
At 0dBu input signal
- (vi) Accuracy: Within ± 1.0 dB

3.2.7 Inter-Modulation Distortion (SMPTE)

- (i) Units: %
- (ii) Generator Frequency: 60 Hz, 7 kHz mixed in ratio of 4:1 (LF:HF)
- (iii) IMD measurement range: 0.01 % to 20 %
- (iv) Residual IMD: ≤ 0.05 % at 60 Hz/ 7 kHz.
- (vi) Accuracy: Within ± 1 dB

3.2.8 Phase

- (i) Range: ± 180 degree
- (ii) Accuracy: Within ± 2 degree, 20 Hz- 20 kHz

3.3 DIGITAL SIGNAL GENERATOR

Digital Signal Generator shall have the facility to generate sine wave, Independent sine wave at A & B outputs, IMD, square wave, Random waveforms (for BIT error test), Dither signals and AES/EBU Interface signal.

Digital output characteristics of the generator should have following features:

3.3.1 Digital output format

- (i) Output formats: AES/EBU, SPDIF, OPTICAL.
- (ii) Sample Rate: 32 kHz to 48 kHz, AES/EBU

- (Selectable)
- (iii) Sample Rate Accuracy: Within ± 20 ppm using internal reference. Lockable to external ref. available on AES/EBU signal format.
- (iv) Word Width: 16 to 20 bit (selectable)
- (v) Output Impedance: 110 Ohms (Balanced on XLR for AES/EBU)
75 Ohms (Unbalanced for SPDIF)

3.3.2 Sine Wave

- (i) Frequency Range: 20 Hz – 100 kHz
- (ii) Flatness: Within ± 0.001 dB
- (iii) Residual Distortion: ≤ 0.001 %
- (iv) Frequency resolution: Better than 0.1 Hz at 48 k sample/sec

3.3.3 SMPTE / IMD Signal

- (i) Frequency: 60 Hz/ 7 kHz
- (ii) Amplitude ratio: 4:1 (LF: HF)
- (iii) Residual distortion: ≤ 0.001 % at 4:1 ratio

3.3.4 Square Wave Signal

Frequency range: 20 Hz - 8 kHz

3.3.5 Dither

Probability distribution: Triangular or rectangular, independent for each channel.

- (i) Amplitude: Suitable for 16-20 bit systems
- (ii) Spectral distribution: Flat (white) or Shaped (+6 dB/octave, triangular)

3.3.6 Random Waveforms

The generator shall be capable of generating Sine wave (range 60Hz-6KHz), pseudorandom noise, Constant values ("digital DC") and traveling zeros and ones for bit error measurements.

(i) Sample Rate: 32 kHz – 48 kHz selectable

3.3.7 Digital Interface Signal

The equipment shall be capable of generating interface signals for extensive evaluation of characteristics of AES/EBU digital audio interface standard. It should have the following features:

- (i) Reference Input Format: AES/EBU
- (ii) Reference Input Sample Rates: 32 kHz to 48 kHz
- (iii) Interface signal Amplitude range: 0.5 -10 Vpp into 110 Ohms
- (iv) Induced Jitter: Sine wave
- (v) Jitter frequency range: 20 Hz to 20 kHz
- (vi) Jitter Amplitude: 0 UI – 22.5 UI (1UI = 160 ns)
- (vii) Residual Jitter: RMS response ≤ 0.01 UI (700 Hz to 22 kHz BW)
Peak response < 0.03 UI (700 Hz to 22 kHz BW)

3.4. DIGITAL ANALYZER

The digital section of the analyzer shall be able to measure level, amplitude, THD+N, Frequency response, Crosstalk, and digital interface measurements. The analyzer shall have the following characteristics:

3.4.1 Digital input format

- (i) Input format : AES/EBU, SPDIF, OPTICAL
- (ii) Sample rate: 32 kHz – 48 kHz
- (iii) Word Width: 16 to 20 bit
- (iv) Input Impedance: 110 Ohms (Balanced on XLR for AES/EBU)
75 Ohms (Unbalanced for SPDIF)

3.4.2 Level / Amplitude measurements

- (i) Range: 0 dBFS to -130 dBFS
- (ii) Frequency Range: 20 Hz – 20 kHz at 48 k samples/sec

- (iii) Accuracy: Within ± 0.01 dB, ≥ -90 dBFS
- (iv) Flatness: Within ± 0.01 dB, 20 Hz – 20 kHz
- (v) Filters: CCIR-QPK, CCIR RMS, 400 Hz High Pass, 15 kHz and 20 kHz Low Pass
- (vi) Residual noise: ≥ -140 dBFS unweighted

3.4.3 THD+N

- (i) Units: % and dB
- (ii) Fundamental range: 20 Hz – 20 kHz at 48 k samples/sec
- (iii) Residual THD+N: ≤ -130 dBFS
- (iv) Residual noise: ≤ -140 dBFS

3.4.4 Frequency measurement

- Range: 20 Hz – 20 kHz at 48 k samples/sec

3.4.6 Digital interface measurements

The analyzer shall display graphically the sub frame bits information such as Parity, Validity, Channel Status and digital audio sample length. The analyzer shall provide display of jitter, rise time and interfering signal problems. The analyzer shall provide measurements for input sample rate, input pulse amplitude, jitter amplitude, time delay (phase) difference between output and input and reference input signals.

- (i) AES/EBU Input voltage: 200 mV - 10 Vpp (balanced),
- (ii) Jitter Amplitude: 0 - 10 UIpp
- (iii) Jitter flatness: Within ± 1.5 dB (100 Hz - 20 kHz)
- (iv) Residual jitter: ≤ 0.03 UI
- (v) Spurious jitter products: ≤ 0.005 UI

3.5 MISCELLANEOUS

Power cord and all required mating audio input/output (analogue & digital) parallel and serial port connectors along with cables shall be supplied along with the equipment.

4. PRINTED OUTPUT

The equipment shall have provision to print graph of sweeps, tabular measured data, and self test results to an attached Dot Matrix Printer/Laser printer through parallel (centronics) port/USB port. However, printer is not to be supplied along with the equipment.

5. ELECTROMAGNETIC COMPATIBILITY

The analyzer shall be used in the vicinity of high Radio frequency field. Therefore, the analyzer will conform to the protection requirements relevant to electromagnetic phenomena as per the guidelines 89/336/EEC / FCC 15 subpart J (class B).

6. SPARES

Essential and recommended spares shall be quoted separately. The list should include name and part no. of the parts/components with quantity and unit in the unpriced schedule of requirement/material. The tenderer shall ensure availability of spares in India for the quoted equipment for a period of at least **ten years** from the date of supply of last equipment.

7. ENVIRONMENTAL CONDITIONS: As per Part 1.0

A test certificate from an approved Test House shall have to be produced.

8. INSPECTION

As per Part 1.0.

9. GUARANTEE

As per Part 1.0.

10. Servicing facility shall exist for servicing of the quoted equipment within India.

2.5.2 TECHNICAL SPECIFICATION OF FIELD STRENGTH METER COMPLETE WITH ALL ACCESSORIES

The field strength meter equipment should have following features;

- i) It should be rugged and portable.

- ii) The system should have fully digital synthesized tuning.
- iii) Digital display to facilitate various field strength measurements along with coordinates, date & time measurement on the equipment itself or on laptop with necessary software. Tenderer shall include all accessories like laptop and GPS receiver etc to make the system complete as per specification.
- iv) Memory for Data; storage and Retrieval. **Internal Memory recall and Display** of user defined frequencies
- v) Auto/Manual calibration and easy to operate.
- vi) Calibrated Antenna with mounting accessories, tripod, RF shielded cable and carrying case as an integral part.
- vii) Demodulator with built in loudspeaker to monitor the programme with suitable access for recording.
- viii) Battery operated built in power source with chargeable batteries (*along with charger*).
- ix) PC based automatic data collection and storage.
- x) Frequency of operation to be continuously displayed
- xi) The equipment should be provided with adequately protection of shielding against RF/EMI interference.
- xii) Integrated or separate hand held GPS receiver with its own display or on laptop for indicating geographic position (*6 figure coordinates*) of places along with date and Time along with the facility to save the multiple readings. Provision should also be to connect with the computer. In case laptop is needed for display etc. to meet functional requirement of GPS receiver and field strength meter, tenderer is required to offer the complete system.
- xiii) Optional : Scanning and reading the frequency with signal level within the selected frequency band and its storage along with geographic position along with necessary software etc..

TECHNICAL SPECIFICATION:

S.No.	Technical Parameter	Specification
(i)	Frequency range	50 Mhz to 500 Mhz
(ii)	Maximum frequency steps	100 Khz
(iii)	RF Input	
	(a) Max. signal	130 dB μ V (3.16 V)
	(b) Filter	Details to be given by the OEM & tenderer
(iv)	Field strength measurement range	0 dB μ V to 90 dB μ V (in dB μ mode)
(v)	Measuring Unit	(dB μ V , dBm, dB μ V/M)
(vi)	Tuning Method	synthesized tuning.
(vii)	(a) Front Panel Display	Graphics LC display with controlled back lighting. Clearly legible.
	(b) Display mode	Average & Peak
(viii)	Audio Detection/Outputs	Output for monitoring with front panel internal

		speaker with volume control .
(ix)	Accuracy	+/- 3 dB
(x)	Input/Output Ports: (a) Data output/control input jack (b) External R.F. calibration connector (c) External RF input connector	Detail to be given by OEM Details to be given by OEM Details to be given by OEM
(xi)	Weight	To be mentioned by the tenderer
(xii)	Dimensions	Details to be given by the OEM & tenderer
(xiii).	Application Software	Details to be given by the OEM & tenderer
(xiv)	Protection against RF Interference	The equipment should be provided with adequately protection of shielding against RF/EMI interference & Details to be given by the OEM & tenderer.
(xv)	Following Accessories are to be offered	Technical Details to be given by the OEM & tenderer
	(a)Battery	Technical Details to be given by the OEM & tenderer
	(b)Battery backup	5 hrs minimum
	(c)Battery charging time	Technical Details to be given by the OEM & tenderer
	(d) Battery charger with necessary sockets/connectors	Technical Details to be given by the OEM & tenderer
	(e)Standard/calibrated antenna for transmission in all VHF band for circular, horizontal & vertical polarization with mounting accessories, tripod , RF shielded cable etc	Technical Details to be given by the OEM & tenderer
	(f) Soft Carrying Case	Technical Details to be given by the OEM & tenderer
	(g) Necessary Connectors	Technical Details to be given by the OEM & tenderer
	(h)All jack etc.	Technical Details to be given by the OEM & tenderer
	(i) Any other item required for completeness of equipment	(Item wise details & part number to be given by OEM & tenderer)
(xvi)	AC supply Voltage for charger	Single Phase as per Part 1.0

2.6 SPECIFICATIONS FOR SETC OF 82.5 KVA (1+1) AT SITE CONDITION STAND ALONE, SELF CONTAINED, WATER COOLED SILENT TYPE DIESEL GENERATOR SET

GENERAL:

The Stand Alone, Self Contained in a weather proof enclosure canopy, Silent type water cooled Diesel Generator set of 82.5 KVA (1+1) capacity (at site condition), 415 V, 3 phase, 50 Hz, 4 wire is required for Broadcast transmitter stations .

SECTION-I:

1. GENERAL

1.1 Scope :

This section covers the general conditions governing the design, supply, manufacture, factory testing, transportation to site, erection , Testing, and Commissioning for satisfactory operation of DG Set at the site .

DG shed , platform, plinth protection , trenches, internal electrical points, fittings etc are to be provided by the tenderer.

1.2 Location :

The Stand alone, Self Contained in weather proof canopy Silent type Water cooled DG set will be installed on cement concrete platform and DG shade for out door application.

1.3 General Conditions :

1.3.1 The DG SET should generally conform to the technical specifications in Section – II..

1.3.2 The DG Set should be designed for efficient and trouble free service for 24x7 hrs. of continuous operation at a stretch. All materials used in the manufacture should conform to the IS: 10002-1981 and 13364(Part-2)-1992 amended to date.

1.3.3 All work should be carried out in accordance with standard mechanical & electrical practice. The units should be designed for ease in operation, maintenance and complete safety to operating personnel.

1.3.4 Only easily available standard components should be used as far as possible. The tenderer should submit an undertaking to make available spares and replacement parts for a period of ten years.

1.4 Completeness of contract:

All fittings and accessories which may not have been specifically mentioned or which the tenderer may not explicitly mention in his tender but are necessary for the satisfactory operation of the DG Set should be deemed to be included in the contract and is to be provided by the contractor without any extra charge.

1.5 Documents to be submitted (with tender)

The tenderer should submit following documents along with technical bid failing which the tender will be considered incomplete and liable to be rejected.

1.5.1 Printed original leaflets with illustrations of DG set Components viz. Engine,

Alternator, ventilation systems, Control Panel and Acoustic canopy.

1.6 **Documents to be submitted After Acceptance of Tender:**

1.6.1 Six copies of the drawings in plan, elevation & section showing the dimensional details, location, accessories etc. of the DG Set should be sent to Indenter within two weeks of acceptance of the tender for approval before taking up manufacturing. Two sets will be returned after approval.

1.6.2 Two copies of installation, assembly at site, operation, maintenance and trouble shooting manual having details of routine, preventive/ corrective and periodical maintenance.

1.6.3 Following documents/details will have to be supplied to the consignee along with the D/G Set at the time of delivery:

- a) Two copies of the book of instructions for the Installation, Testing, Commissioning, Operation and Maintenance of DG Set.
- b) Factory Test Certificates showing the results of tests actually conducted on the Engine, Alternator & Accessories.
- c) Two sets of finalized drawings showing dimensions and other fixtures on the DG Set including wiring of panel.

1.6.4 Two set of drawing and Manuals/instruction book-let etc of DG Set should be sent directly to Director Engineering (Project), P&D Unit, DG : AIR, Akashvani Bhawan, New Delhi as soon as drawings are approved by the Indenter.

1.7 Delivery Period: Please refer Part 1.0

1.8 **GUARANTEE:**

Please refer Part 1.0 and the DG Set should be guaranteed in all respects for satisfactory operation under full load condition for one year from the date of taking it into service.

1.9 **SPARES:**

Along with the diesel generator, the Tenderer should also quote separately for recommended spares for two years operation of DG set giving list of all the spares alongwith price of each item of spare by considering that DG set will be running continuously for at least 12 hrs. per day . The list of recommended spares should be based upon field reports and should be sufficient enough for trouble free operation of the DG Set at remote locality.

1.10 **MISC. CONDITIONS :**

1.10.1 The supplier should make good/repair the damage to indenter building during installation, testing etc. of the DG set.

1.11. **TESTING/ACCEPTANCE AT SITE:**

The supplier should show all the required tests at site as per mutually agreed acceptance procedure according to relevant standard of BIS for such jobs at no load, partial load and full load (in steps of 20% from no load to full load). The consumable items like fuel, lubricants, belts etc. during this testing should be arranged by the tenderer.

1.12 Tenderer should arrange at site the load for testing at no load, partial load and full load (in steps of 20% from no load to full load) and for over capacity test as per Section II.

1.13. **C E A CLEARANCE:**

25th October, 2010

The supplier should have to arrange CEA clearance for DG set before the same is offered for acceptance to indenter at site.

SECTION-II

2. TECHNICAL SPECIFICATIONS

The stand alone, silent type, Water Cooled, D/G set mounted on a self contained rust proof chassis complete with weather proof, sound proof Acoustic enclosure with built in exhaust & ventilation system. D/G Set should meet the noise level. All units & accessories should be housed on single chassis inside the enclosure.

2.1 ALTERNATOR: The Alternator will conform to IS : 13364 (Part - 2) – 1992 for manufacturing , Enclosure of alternator as per IS : 4691 IP 23, mounting as per IS : 2253 & testing of Alternator as per relevant IS with latest amendments. **The Alternator must be of ISO certified manufacturer like KEC / STAMFORD/ AVKC.**

S. No.	Item	AIR's Requirement	Tenderers Offer
2.1.1	Electrical Output (Prime Power)	82.5 KVA at site conditions	
2.1.2	Make	To be indicated by tenderer.	
2.1.3	No.of phases & interconnection between phases if any	3 phase with Neutral point in terminal box, Star Connected	
2.1.4	Rated Voltage	415 V (Nominal)	
2.1.5	Voltage regulation	± 1.0 % from no load to full load at lagging power factor of 0.8 to 1.0 and speed drop of less than or equal to 4%	
2.1.6.	Power Factor	Better than 0.85 (lagging)	
2.1.7.	Frequency in Hz	50 Hz ± 4 %	
2.1.8	Speed in RPM at rated load	1500 RPM	
2.1.9	Type of coupling	Alternator to be coupled either directly to engine or through flexible rubber coupling on a common fabricated base frame	
2.1.10	Exciter	(I) The alternator should be self regulated, self excited and rated for continuous operation from no load to full load under all working conditions. (II) The alternator should be able to supply unbalanced load as specified in IS : 13364 (Part-2) : 1992 with latest amendments.	
2.1.11	Exciter rating	It should be rated for 1.25 times the full load conditions	
2.1.12	Earthing	As per IS:3043 – 1987 amended to date	
2.1.13	Type of load to be connected	i. Broadcasting Transmitter load instantaneously and continuously varying above a specified limit. ii. Building light, Flood lights and Power Loads.	

Specification no: SETC-10 KW TX (1+1) Naushera (Mangla Devi Fort) /J&K / October/ 2010/D (TD/FM)

2.1.14.	Maximum load switched On/Off	65 KVA	
2.1.15	Type of Duty	Continuous	
2.1.16	Type of Field	Rotating	
2.1.17	Class of Insulation	Class 'H'	
2.1.18	Construction	Horizontal, foot mounted with ball or roller bearing and end shields	
2.1.19	Cooling	Machine should have cooling provision as per IS : 6362 - 1971 IC 01 amended to date	
2.1.20	Temperature rise	Limited to Class H as per IS 12802 and IS 4722:1992 amended to date	
2.1.21	Overload capacity	1.5 x rated FLC for 30 secs. or 1 hr within 6 hrs with 10% over load	
2.1.22	Over speed	To withstand the speed of 1.2 times of the rated speed.	
2.1.23	Protection against short circuit	Short circuit protection to be provided .(Pl. indicate the device/system used.)	
2.1.24	Vibration	As per IS - 12075:1987 amended to date	
2.1.25	Noise	As per IS 12065: 1987 amended to date	
2.1.26	(i) Output Terminals	Terminal box should be mounted on top of stator body suitable for connecting 400 Sq. mm 3 ¹ / ₂ core PVC insulated PVC sheathed Aluminum conductor armored cable 1.1 KV grade LT Cable	
	(ii) Terminal Marking	As per IS 4728: 1975 amended to date	
2.1.27	De-rating Parameters & output at site condition	To be given by the Tenderer.	
2.1.28	Rated FLC	To be given by the Tenderer.	
2.1.29	Efficiency at 0.85 p.f. (lag)	More than or equal to 92 % for 25 % to 100 % Load. Design of Alternator should be such as to have maximum efficiency at 75 % of Prime Power rating at NTP.	
2.1.30	Waveform Distortion (THD)	As per IS	
2.1.31	Unbalanced load permitted	Not exceeding 20% rated FLC in any phase	
2.1.32	Regulation	As per IS	

S. No.	Item	AIR's Requirement	Tenderer Offer
2.2.1	Type of engine	Self-start, 4 stroke, Turbo-charged	
2.2.2	Make	To be indicated by tenderder	
2.2.3	Capacity	i. To be rated for continuously driving the alternator to deliver the rated full load output at site condition . ii. The Tenderer should specify the capacity (BHP at site condition) of the Diesel Engine offered by him alongwth the	

		computations of various de-rating applied as per relevant IS.	
2.2.4	Type of fuel	H.S. Diesel Oil	
2.2.5	Method of Cooling	i. Water-cooled with Radiator. ii. Provision for anti-rusting, anti-corrosion & anti freeze arrangement for water coolant is to be provided, if applicable. iii. Jacket Water system should be free from rubber hoses for reducing the risk of leakage and therefore engine failure. iv. Cooling System should be provided with Twin Thermostats, permanent lubricated water pump.	
2.2.6	Method of starting	i. The Engine should be cold starting type. ii. It should be battery started iii) Starting switch with key should be provided on engine control panel. Starting motor with battery charging alternator alongwith voltage regulator and activation switch should be integral part of the starting system. iv) One Ammeter should also be provided in the battery Charging circuit. (v) Battery offered should be maintenance free tubular electrode type of standard make like EXIDE/STANDARD FURUKAWA etc. and complete with charging connecting leads, & terminals. The Ampere hour rating and no. of plates of battery should be indicated. (vi) Suitable heating system is to be offered by the tenderer for starting along with accessories.	
2.2.7	Capacity of fuel tank	Service Tank of greater than or equal to 225 liters capacity with suitable dial type fuel gauge. (NB: Tank should be part of self-contained cabinet & housed suitably.)	

DIESEL ENGINE

2.2.8	Speed of Engine	1500 RPM with class A1 governing as laid down in IS-10000.	
2.2.9	Type of Exhaust system	A heavy-duty residential type exhaust silencer to be provided.	
2.2.10	Engine protection	i) The Engine should be protected against High water temp. with audio & visual alarm. ii) Over speed protection through hour meter cum RPM indicator with Audio and visual alarm. iii) Low Lubricating Oil Pressure Protection with audio and visual Alarms.	
2.2.11	Accessories for Engine	Standard Accessories	
2.2.12	Vibration Insulation	Anti-Vibration Pad of Polybond/ Resinoflex make should be provided.	
2.2.12	Base frame	Common MS channel fabricated, rigid, rust proof & with suitable anti-vibration mounting .	
2.2.13	Consumption of	<u>At Site Conditions:</u>	

	fuel and lubricant(Ltrs/hrs) The Tenderer will submit this data for both i.e. at site condition & NTP.	(a) lts/hr at 25 % load. (b) lts/hr at 50 % load. (c) lts/hr at 75 % load. (d)lts/hr at 100 % load. <u>At NTP:</u> (a) lts/hr at 25 % load. (b) lts/hr at 50 % load. (c) lts/hr at 75 % load. (d)lts/hr at 100 % load.	
2.2.14	Lub. oil specification with antifreeze.	As per IS	
2.2.15	Total lubrication system capacity	To be given by the Tenderer	
2.2.16	Total coolant capacity	To be given by the Tenderer	
2.2.17	Fuel system	Direct fuel injection system with fuel lift pump inline type.	
2.2.18	Exhaust Gas Volume	To be given by the Tenderer at 75 % and 100 % prime Power rating	
2.2.19	Exhaust Gas Temp.	To be given by the Tenderer at 75 % and 100 % prime Power rating	
2.2.20	Smoke Level	Harmful Gaseous emission should meet the Pollution Board norms for Environment protection.	
2.2.21	Regulation	As per IS	

2.3 COMPLETE DIESEL GENERATOR SET:

S. No.	Item	AIR's Requirement	Tenderer Offer
2.3.1.	Type of DG set	Silent ,Self contained, Standalone with acoustic enclosure.	
2.3.2.	Dimensions of D/G Set including Acoustics Enclosure	(a) Length : To be given by the Tenderer (b) Width : To be given by the Tenderer (c) Height : To be given by the Tenderer.	
2.3.3.	Total Weight of D/G Set	To be given by the Tenderer.	
2.3.4.	Type of Enclosure	DG set should be housed in a Acoustic Enclosure consisting of Acoustic Insulation, Non-inflammable, Canopy Ventilation System with CFM details , doors and suitable for outdoor use.	
2.3.5.	Noise level	Complete D/G set including Engine should meet the Pollution Board norms as per IS	
2.3.6.	Smoke Level	Harmful Gaseous emission level should meet the Pollution Board norms for Environment protection at the time of delivery of DG set.(Original certificates to be enclosed from authorized agency)	

2.3.7	Exhaust pipe	Exhaust stack height : Minimum exhaust stack height for DG Set up to 1000 KVA $(H) = h + 0.2\sqrt{KVA}$, Where h is the height of building. or as per IS / specification of Pollution board amended upto date.	
2.3.8.	EARTHING	As per IS	

2.4 ENGINE AND ALTERNATOR CONTROL PANEL

S.No.	<u>INDENTOR REQUIREMENT</u>	Tenderer Offer
2.4.1	Control panel for 415 V 3-phase, 50 Hz , 4wire AC supply should have following features & accessories.	
i.	It should be mounted on the enclosure with hinged panel and will be wired up as per standard practice & as per I.E. rules.	
ii.	It should be fabricated out of CRCA SHEET dust proof, vermin proof & power coated.	
iii.	The Alternator control panel is to be provided with 400 Amp (Draw out type) 4 Pole MCCB & adequate space for connecting outgoing & incoming as per IS . The rating of MCCB/ contactors/ relays will be suitable for 82.5 KVA and rating of interconnecting copper cables should be suitable for taking at least 1.5 time the rated current.. All copper cables control wiring lugs extra are part of SETC.	
2.4.2.	The Panel should comprise of following <u>Instruments</u> : (a) Start/Stop switch with key (b) Local/Remote control switch (c) Frequency meter (d) DC Voltmeter & Ammeter for battery charging (e) AC Voltmeter (Flush type) with Selector switch (f) Multifunction meter (kW,Pf,kVA,kVAR) (g) Ammeter (Flush type) having scale more than 20% full load current with selector switch (h) Instrument fuses/ MCBs (i)Low oil pressure & high water temp. Audio alarm. (j) Priming pump starter(k) Hour meter (l) RPM meter (Tachometer) (m) KWH meter	

2.4.3.	<p>The Panel should comprise of following Indications :</p> <p>(a) Set ON (b) Load ON (c) Remote control (d) Low Lubricating oil pressure (e) Over speed (f) High Enclosure temp. (g) High water Temp.</p>	
2.4.4.	<p><u>PROTECTION : FOR GENERATOR :</u></p> <p>(A) <u>ALTERNATOR</u>:</p> <p>i) Earth fault protection through relay. ii) Under voltage protection through relay. iii) Under frequency protection through relay. iv) Over current (through MCCB/ACB release) v) One set of fuses should be provided for instruments & control circuit.</p> <p>(B) <u>ENGINE</u>:</p> <p>i) Protection against following a. Engine Over speed b. Low Lube Oil pressure c. High water Temp. ii) One set of audio and visual Alarm for above protection.</p>	
2.4.5.	<p>The Engine Local Control Panel should have following features</p> <p>a) Start/stop push button with key for local starting. b) Special switch (or any other method) on the local control panel providing locking in any of the three positions- i. Remote ii. Local iii. Off-No rotation at all. c) A timer to ensure that the starter is not pressed for a long time. d) A pressure switch to ensure that the starting motor is not energized, when the generator is running. e) Lubricant Oil Temp. gauge f) Hour cum Tachometer</p>	
2.4.6.	<p><u>Power supply for Space Heaters of Engine</u> :</p> <p>Suitable arrangement through push buttons should be made for power supply to Space heaters from the battery of DG set. The Ampere Hour rating of the battery may be offered accordingly.</p>	

5. Load for testing to be arranged by the tenderer.

6. Acoustic Enclosure

1. The Diesel Generator and its control panel will be mounted in an enclosed acoustic (sound attenuated) chamber outdoor away from the technical area.

2. The enclosure should provide noise reduction of DG set to a level of 68-72 dB at a distance of 3 meters from external wall of the DG set.
3. The acoustic enclosure should be weatherproof, strong and suitable for outdoor location. It should be made out of 16 SWG CRC sheet press bent to designed shape and provided with internal acoustic on all the five sides including door and roof.
4. The insulation should be covered with tissue paper and perforated sheet.
5. The wall and roof panel will comprise double wall CRC press bent sheet outside and perforated CRC sheet inside.
6. The enclosure should be collapsible type for easy dismantling.
7. The enclosure should also be provided with a lockable access door for convenient entry of operating and maintenance personnel and for removal of diesel generator for repairs as and when required.

2.7. SETC SPECIFICATION of 62.5 KVA (1+1) DG SET FOR ANCILLARY LOAD

SECTION - I

1. Scope

The scope will cover Supply, Erection, Testing and Commissioning of a 62.5KVA capacity (at site) 3 phase, 50 Hz, 415 volt AC, air-cooled Diesel Generator set with brush-less excitation for radio and TV transmitters for J&K region. The (DG set) will be provided with suitable acoustic enclosure for outdoor location in environmental condition Part 1.0. The schedule of requirement is given in Part 4.0 of this specification.

2. General

- 2.1 The Diesel Generator set will be used as a captive power supply source for providing AC power to the set up. The DG set should be ergonomically designed, reliable, rugged and easy to install, use and maintain.
- 2.2 The generator should consist of engine, alternator, control panel, remote control (ON/OFF) arrangement and a battery along with the other items required for the completion of the installation as per Indian Electricity act.
- 2.3 The Diesel Generator and its control panel will be mounted in an enclosed chamber outdoor near the transmitter container.
- 2.4 The acoustic enclosure for the DG should be water proof, weatherproof, strong, durable and should be made of rustproof metal with internal acoustic and thermal lining. The enclosure should be provided with a lockable access door for convenient entry of operating and maintenance personnel and for removal of Diesel Generator for repairs as and when required.
- 2.5 The Diesel Generator shall be mounted on a specially designed heavy duty steel fabricated steel plate having all welded construction and placed on suitable anti-vibration pads/ cushy foot mounting so as to minimize transmission of vibration to the floor of the enclosure. The entire acoustic enclosure/chamber will be kept on concrete platform to be provided by the tenderer.

3. General Terms & conditions

- 3.1 The DG set will be complete with all the necessary accessories.
- 3.2 The Diesel Generator shall be supplied for efficient and trouble-free service for long duration of continuous operation. All materials used shall be of high quality and the overall quality of DG set should conform to the IS specification No. 4722:1992
- 3.3 All work shall be carried out in accordance with standard electrical practice. The units shall be designed for easy maintenance and complete safety to operating personnel.
4. Only easily available standard components should be used as far as possible. The tenderer should undertake to make available spares and replacement parts as and when required for a period of 10 years.
5. The tenderer shall submit the following documents in duplicate with the tender.

- a) Leaflets with illustrations relevant to the components offered.
 - b) Complete schedule of accessories.
 - c) Construction detail of acoustic enclosure
 - d) Complete Technical Compliance statement as per part 1.0 of the specification.
 - e) Acceptance test procedure for pre dispatched inspection and site inspection after installation is over. The ATP should cover the detailed inspection and testing procedure to check genuineness and performance of the product offer.
6. The following documents are to be supplied after acceptance of tender to the Indenter.
- a) Instruction manual for the installation operation and maintenance of Diesel Generator.
 - b) Two sets of drawing including wiring of panel. Two copies of instruction manual and two sets of drawings are to be supplied to the consignee at the time of delivery.
 - c) Supply of fuel consumption data at different loading of the alternator, i.e. No load,20%,40%,60%,80%, Full load and permissible over load.
 - d) Manufacturer test certificates on engine and alternator as conforming to the relevant IS.
 - e) Total weight and base plate details and dimensions are to be provided.
 - f) Construction details of acoustic enclosure.
8. Guarantee:
The Diesel Generator should be guaranteed in all respect for the satisfactory operation under full load condition for one year from the date of taking it into service.
9. Spares and Tools:
Along with the diesel generator, the tenderer shall also quote separately for recommended spares for two years operation of DG set giving list of all the spares along with un priced bid.
10. The electrical earthing of the machine shall be done in accordance with provision of IS-3043: 1987.
11. Special conditions to be fulfilled:
DG set to be supplied shall be fitted with heavy duty silencer to attenuate audio frequency noise from exhaust.
12. Tenderer shall provide heating system for subzero temperature and antifreeze.

SECTION-II

SCHEDULE OF REQUIREMENTS: Please refer Part 4.0

Notes:

- a) The firm should produce test certificates of Diesel Generator & Alternator from the Manufacturer.
- b) Recommended list of spares (for two years operation of DG sets) and list of tools along with price of each item is to be annexed with the un priced bid.
- c) The extension of the diesel generator output from Control Panel to changeover switch on LT panel in LT switch-gear room will be done by tenderer.

SECTION-III

I.	ALTERNATOR	REMARKS
1.	Electrical output (continuous) in KVA	62.5 KVA at site
2.	No. of phases and in case of poly-phase machines, inter-connection between the phases if any.	Three phase with neutral star connected.
3.	Rated voltage	415 Volts (Nominal)
4.	Power factor	0.8
5.	Frequency in Hz	50 Hz +/- 0.5 Hz
6.	Direction of rotation	Clock wise looking from driving end.
7.	Speed in RPM	1500
8.	Type of enclosure of alternator	Screen protected drip proof.
9.	Type of coupling direct or by belt	Engine is to be coupled directly to alternator. Chain or belt drive is not acceptable.
10.	Exciter(self or separate)	i) The alternator shall be self regulating and shall have its own brushless exciter and rated for continuous operation from no load to full load under all working conditions. ii) The alternator shall be able to supply unbalance load as specified in IS 13364 Part-II:1992.
11.	Type	Rotating field, salient pole brushless alternator complying to IS 4722:1922
12.	Class of Insulation	Rotor Class 'F' stator Class 'B'
13.	Voltage regulation	Shall be within +/-2.5% from no load to full load.
14.	Neutral point	The neutral point is to be brought to the terminal block and earthed as per I.E. rules/IS code.
15.	Cooling	Self ventilated forced air cooling.
16.	Bearing	Anti-friction grease lubricated ball/roller bearing
17.	Temperature rise	As per IS 4722:1992
18.	Overload capacity	10% overload for one hour in every 12 hours.
19.	Occasional excess current for AC generator	Shall be capable of with standing a current equal to 1.5 times the rated current for not less than 30 seconds.
20.	Voltage frequency measurement	Display through separate meters.
21.	Vibration	As per IS 12075:1987
22.	Noise	As per IS 12065:1987 (for studio refer to special conditions)
23.	i) Terminal ii) Output Terminals iii) Terminal marking	Three phase with Neutral The alternator output terminal shall be mounted in a suitable box. As per IS 4728:1975
24.	Whether rated output is required at NTP or site condition	At site condition taking into accurate de-rating factor as per IS:1601

II.	DIESEL ENGINE:	
1.	Type of engine & fuel to be used	i) Diesel oil, air cooled confirming to IS 10002 and IS 10000/80 Part VII with amendment 1&2 or BS-5514. The fuel pump should be block type. ii) Electric start, 4 stroke 4 cylinder diesel engine designed to run continuously at 1500 RPM complete with all the standard accessories.
2.	Method of starting	The engine shall be cold starting type
i)	Hand starting, battery starting or compressed air starting	Electric starting from 12/24 volt lead storage battery with facility of remote operation. Manual starting facility is also to be provided. DC voltmeter DC ammeter shall be provided for starting battery. DG Set offered with compressed air starting will not be accepted
ii)	Battery	Yes, battery offered should be of good quality and reputed make given in section II-4 of suitable capacity.
3.	Capacity of fuel tank in liters required	Service Tank of greater than or equal to 120 liters with suitable dial type fuel gauge. (NB: Tank should be part of self-contained cabinet & housed suitably.)
4.	Speed of engine directly coupled	1500 RPM with class 'A; governing as laid down in IS 10000/BS-5514.
5.	Engine protection equipment (Load oil pressure, indicator, cooling air thermostat engine over speed, cooling air temperature indicator etc.) provide details in the technical bid	i) The engine shall be totally enclosed type and preferably be fitted with positive pressure system of lubrication to the moving parts. No moving part shall require lubrication by hand either prior to the starting of engine or while it is in operation. ii) Over speed protection through frequency monitoring with audio and visual alarm. iii) Low lubricating oil pressure relay. iv) Protection against high cylinder head temperature with audio and visual alarm. v) Lubricating oil filter shall be provided for operation under normal conditions for engine for a period of 500 hours without the necessity of replacement or cleaning.
6.	Instrument's required for the engine	i) Lubricating oil pressure gauge. ii) Lubricating oil temperature gauge.

		iii) Battery charging ammeter.
7.	Site conditions a) Max. ambient temperature b) Max. humidity and corresponding temperature c) Relative Humidity d) Altitude above mean sea level in meters	As per Part 1.0
8.	Whether rated output required at N.T.P. (as per IS-10000/BS-5374) or at site conditions	At site conditions
9.	Type of mounting:	The DG set shall be mounted on specially designed heavy MS channel base (provided common bed for engine alternator coupled together) from a regular foundation in a diesel room. The foundation details will be supplied by the supplier of the equipment. The DG set will be mounted on cushy foot mounting so as to absorb vibrations.
III.	Control and Exciter panel:	
1.	Type of panel and type of mounting	Indoor type floor mounted, dust proof front door. All components shall have labels fixed on the panel. The control panel shall be completely assembled, wired up and connected for ready installation. The panel shall have required switches/circuit breakers of suitable rating aluminium bus bar, CTs, neutral link, earthing bolt, power and control terminals, AC voltmeter AC ammeter, frequency and hour meter, indicating lamp, instrument fuses and various protections as mentioned in the subsequent clause 2 to 7
2.	Type of switch and protection etc., and other arrangement	<ul style="list-style-type: none"> i) Moulded case circuit breaker MCCB as per IS with over load and short circuit protection of a rating suitable for capacity of DG set. ii) One set of fuses shall be provided for instruments and control circuit. iii) Earth fault protection through relay. iv) Under voltage protection through relay. v) Under frequency protection through relay vi) The control panel will also be completed with internal wiring and labeling.
3.	Local/remote start	The local/remote starting facility shall have following features: a) Start/stop push button for local starting

		<p>b) Special switch on local control panel providing locking in any of the four positions. 1. Local, 2. Remote, 3. Off 4. Test.</p> <p>c) A timer shall be provided to ensure that the starter is not pressed for too long at a time.</p> <p>d) A pressure switches to ensure that the starting motor is not energized, when the generator is running. This can be operated from the oil tube pressure.</p>
4.	Ammeter	
a)	Whether one for each phase or only one with rotary switch	One with selector switch
b)	Size of scale	The ammeter scale shall not be less than 20 A above the full load current.
c)	Type of movement	Moving iron type (Ferro magnetic)
d)	Accuracy	Industrial grade 'A' as per relevant specification
e)	Whether flush or projected pattern	Flush
5.	Voltmeter (R-Y-B)	One number with selector switch (0-500 V)
6.	Indicating lamp	Three numbers (Flush mounted) in different colour ,with fuses
7.	Frequency meter & hour meter	To be provided
8.	Multifunction Meter	To be provided
9.	Tools	A standard set of tools like Double ended spanner set, Screw Driver set, fuel gauge, 'O' ring push rod, etc required for daily maintenance purposes should be provided.

7. Acoustic Enclosure

1. The Diesel Generator and its control panel will be mounted in an enclosed acoustic (sound attenuated) chamber outdoor away from the technical area.
2. The enclosure should provide noise reduction of DG set to a level of 68-72 dB at a distance of 3 meters from external wall of the DG set.
3. The acoustic enclosure should be weatherproof, strong and suitable for outdoor location. It should be made out of 16 SWG CRC sheet press bent to designed shape and provided with internal acoustic on all the five sides including door and roof.
4. The insulation should be covered with tissue paper and perforated sheet.
5. The wall and roof panel will comprise double wall CRC press bent sheet outside and perforated CRC sheet inside.
6. The enclosure should be collapsible type for easy dismantling.
7. The enclosure should also be provided with a lockable access door for convenient entry of operating and maintenance personnel and for removal of diesel generator for repairs as and when required.

8. Load for testing to be arranged by the tenderer.

2.8 Specifications for SETC OF 3 Phase, 4 Wire, 40 kVA on line Uninterrupted Power Supply System

SCOPE:

The specifications are for the SETC of 3 Phase, 4 Wire, 40 kVA, True on-line double conversion continuous operation (defined as VFI in the IEC62040-3 UPS Specifications), solid-state Uninterruptible Power Supply (UPS) along with Battery and Isolation Transformer for use in AIR FM transmitters (power factor better than 0.8). The UPS system has to operate in conjunction with the existing Building Electrical System and Diesel Generator to provide power conditioning, back-up power protection, and power distribution for the critical loads.

GENERAL:

The UPS should be reliable and stable in operation under Indian tropical conditions. In India climate may be extremely humid and dusty besides varying from very cold to very hot. It should have a front panel LCD display to show various parameters of the system to ease the monitoring.

The UPS system shall be capable of running in stand-alone Mode as per the attached configurations shown in Fig. 1. UPS is to be supplied with 15 minutes back up time at full rated capacity.

It will be the responsibility of the Tenderer to arrange for the demonstration of offered UPS at company site (preferably in Delhi) and show, practically, compliance of various parameters claimed in the tender if required by AIR.

ESSENTIAL FEATURES:

1. (a) The system should be fully DSP controlled in all respects (i.e. rectifier control, inverter control, display, digital diagnostics.), solid-state type, utilising On Line Double Conversion technology (high frequency PWM using IGBT Rectifier & inverter section)
(b) The system should be capable of providing continuous high quality sinusoidal waveform power for electronic equipment loads.
(c) The system should conform to voltage frequency independent technology.
2. The DSP based controller should have following characteristics:
 1. Diagnostic monitoring achieved by Fast Fourier Transform (FFT) of spectrum analysis
 2. Adaptive control by having the speed to monitor and control the system concurrently
 3. Real time generation of smooth, near optimal reference profiles and move trajectories
 4. Control power switching and inverters and generate high resolution outputs

Note: The firm shall mention the DSP chip used in the control system of the UPS.

3. The UPS should offer low input current harmonic distortion (THDI), good regulation, excellent transient response and high stability.
4. (a) The system should have a monitoring panel (LCD Based) with various types of fault alarms and metering functions including:
 - i. Output voltage, current & frequency.
 - ii. Input voltage, current & frequency.

- iii. Bypass Voltage, Current & frequency.
 - iv. Battery capacity, backup time left & bad battery indication.
 - v. Temperature of System, Inverter section and Rectifier section.
- b) The UPS system should display both RMS value and Peak value of load current.
- c) The UPS system should have facility to generate aural alarm for bad Battery condition.
5. a) The system should have wide input voltage and input frequency tolerance as specified in Rectifier section.
- b) Transient Voltage Surge Suppressor (TVSS) should be provided at the input & output of the UPS System.
6. The system should have provision for controlling all the three phases individually, even in case of 100% unbalancing at the output with even 0% load on one phase. There should be no change in regulation in phase voltage with 100% unbalancing.
7. The system should be capable of supplying energy to load from commercial mains without any break in case of phase reversal at the input. It should also generate aural and visual alarm in such a case.
8. a) The system should have provision of protection for
- (i) Input under voltage
 - (ii) Input Over Voltage
 - (iii) Output Over Voltage
 - (iv) Output Over load
 - (v) Output short circuit
 - (vi) Battery under Voltage
 - (vii) Over temperature
 - (viii) DC Over current
- b) The system should generate aural and visual alarms for above-mentioned conditions.
9. The system should have Controls as
- (i) Input Circuit Breaker
 - (ii) Bypass Circuit Breaker
 - (iii) Maintenance Bypass Switch
 - (iv) Inverter ON / OFF Switch
 - (v) Alarm acknowledge switch
10. (a) The system should have facility to store the Logs of the events being monitored by monitoring system.
- (b) The UPS system should have the capability to store a minimum of last 100 events.
- (c) The UPS should have in – built digital fault diagnostic through stored events in UPS system.
11. The system should also include a 60kVA Isolation Transformer in the UPS to provide protection from electrical surges/noise (inherent and generated both) present in the input power supply.
12. The firm should specify the nos. & type of desired batteries, which shall be part of the system to

be offered. [The batteries of known & reputed world –class manufacturer only will be accepted.] The maintenance free-batteries VRLA type shall only be acceptable. The detailed technical specification of batteries with their working life is also to be specified and provided with the offer.

13. A- The battery charger should have provision of
 - (i) Monitoring battery temperature and accordingly adjusting the charging level to enhance the battery life.
 - (ii) Programmable battery charging which can be programmed to enhance battery life.B- Battery charging current should be adjustable from 10% to 80% through Microprocessor & displayed.
C- For battery sizing calculation, temperature is required to be taken as 0°C.
14. The system should have communication port RS 232 and should be compatible to integrate with NMS. Suitable software for monitoring & diagnostics etc. should be supplied.
15. The system should be designed with scientific forced air-cooling for proper ventilation. Acoustic noise level should be kept at minimum.
16. The UPS system output should be isolated from the DC circuit of the UPS.
17. The project, consisting of Supply, installation and commissioning of the Online UPS, will have to be implemented on turnkey basis.
18. The firm should specify the total area requirement for installation of the system including batteries. A floor-Layout plan should be attached.
19. The system that shall be quoted against this tender should include all switchgears, cables, earthing etc. Terminals for input 3 phase, 4 Wire, power supply & output power supply should be provided.
Power supply sub distribution in the output is not in the scope of this tender. A block-schematic diagram with all items should be provided.
20. The system that shall be quoted against this tender should be capable of running continuously round the clock, seven days a week without interruption or failure.
21. Firms offering the system **should have experience of at least three years** in the installation and commissioning of ON_LINE UPS for similar applications on turn key basis. **The tenderer shall enclose the user list (along with phone number, fax, email) of such installations therein clearly mentioning the name of the users/ installations, date of system installations, details of system installation completed and level of satisfaction of the user.**
This office shall reserve the right to contact such users to cross check and obtain feedback about the system. **The tenders without the user list shall be rejected.**
22. Compliance statement should be given from the original manufacturer of the UPS on its letterhead duly signed and stamped by the OEM.

23. The UPS System quoted must conform to the latest international standards of safety and EMC. The conformance to such standards (indicating standard's name & number) must be stated in compliance statement. A certificate issued to OEM by authorized international/ national agencies should be submitted along-with the declaration from OEM in this regard. In general, following standards should be met: -
- A. Safety: IEC 62040-1 / EN 50091-1
 - B. Emission and Immunity: IEC 62040-2, Class A / EN 50091-2 (Class A)
 - C. Performance: IEC 62040 –3/ EN 50091 – 3
 - D. CE-Marked in accordance with EEC directives 73/23 “low voltage” and 89/336 “electromagnetic compatibility”

A. SYSTEM

1. Technology: The UPS shall be designed to operate as **true on-line, double conversion DSP controlled type UPS** strictly as per the definition of IEC 62040-3 as follows:

a) Normal Operation:

The UPS inverter should continuously supply the critical AC load. The rectifier & charger should take power from the AC input source, convert it to suitable DC and supply to the inverter as well as charge the Batteries on Automatic Float cum Boost Mode.

b) Upon Mains Failure:

Upon failure of AC input power, the critical AC load should continue to be supplied by the inverter, which should obtain power from the battery. There shall be no interruption in power to the critical load upon failure or restoration of the AC input source (Mains/ DG).

c) Upon Mains Restoration:

Upon restoration of AC input power, the Rectifier/Charger should automatically restart walk-in and gradually take-over the supply to inverter and charging to the battery.

d) Static Bypass:

UPS Module should have in-built 100% rated static Bypass Line.

All the loads should be transferred to the Static Bypass Line of the UPS without any break for the following conditions:

- i. If the UPS fails
- ii. If overload beyond 150% for 1 minute is faced by the UPS
- iii. If UPS sense over temperature (i.e. inverter exceeding 65 Deg Celsius simultaneously).
- iv. If both the UPS inverters are put-off

2. MTBF of the System: Bidder to specify and justify MTBF of the system
3. Capacity: 40 KVA at power factor 0.8

4 B.RECTIFIER SECTION

1. **DSP Controlled IGBT Rectifier with input filters to reduce the harmonics.**
 - (a) Technology
2. Input 3-phase, 4-wire plus Ground
3. Input Voltage 320 to 460 V (at full load)
4. Input Frequency 47 – 53 Hz
5. Input Power factor > 0.96
6. Input Current Harmonic Distortion (THDi) ≤ 4%
6. Soft start (0-100%) > 10 Sec
8. DC ripple voltage < 1%

Note: Bidder should Specify the following Parameters for quoted UPS system

- i) Rectifier Input current (Max.)
- ii) Max. Rectifier output current
- iii) Rated Output current (with battery)

in fully charged state)

iv) Max. Output Voltage

- 4 C. INVERTER:
1. **Technology** **Fully DSP based IGBT/PWM Inverter**
 2. Output Voltage 3-phase, 4-wire plus Ground
 1. Nominal: 380V- 415V AC (adjustable), 50Hz
 2. Static: 400 \pm 1% V AC, 50Hz
 3. Output voltage regulation:
 - a) 100% Balanced load < \pm 1%
 - b) 100% Unbalanced load \pm 2%
 - c) Transient response (100% step loading) < 5%
 - d) Recovery time to steady state (<math>\pm 1%) < 5 msec.
 4. Output frequency regulation
 - a) Line Connection: \pm 1% (meeting input frequency range of 47-53 Hz.)
 - b) Self Connection: \pm 0.05%
 5. Overall Efficiency: >90% (for all loads from 50% to 100%)
(From I/P to O/P of the U.P.S. system)
 6. Output voltage Distortion: < 1% linear load,
 (at rated load) < 4% non-linear load with **3:1 crest factor**
 7. Audible noise level at 1 meter 60 dBA or better
 8. Overload capacity:
 - (a) Inverter Upto 125% 10 min
Upto 150% 1 min
 - (b) Bypass Mode Continuously upto 135% of rated current
135% to 170% of rated current for 1 min
> 170% of rated current for 2 seconds
 9. RFSuppressions: As per BIS & EMC standard.
 10. Computer Interface: RS 232 Interface
 11. On– Line Battery testing: Required
 12. (a) Mains failure,
 (b) Battery Low,
 (c) UPS Fault Vendor to provide Audio/Visual alarm at remote location (maximum distance 100 meter) in addition to local.

13. Front panel Display
(Please submit the details of front panel display)

LED mimic with LCD display. The LCD should display the following:

- a) Input side:
 - i) Voltage
 - ii) Current
 - iii) Frequency
- b) Output side:
 - i) Voltage
 - ii) Current (RMS value) & Peak value.
 - iii) Frequency
- c) Intermediate DC:
 - i) Voltage
 - ii) Current
 - iii) Remaining time (in minutes)
- d) Bypass:
 - i) Voltage
 - ii) Current
 - iii) Frequency
- e) Alarm History

4 D. BATTERY BANK & BATTERY

1. Battery Bank Capacity Minimum 45,000 VAh
2. Nominal output current capacity Minimum 80 Ah
3. No. of Battery String 1 set complete
4. DC Voltage of the battery bank Should be Minimum 360 V
5. Type: 2 V cells of Maintenance Free **Valve Regulated Lead Acid (VRLA)**. (Please submit the catalogue of offered battery) with its detailed specifications along with the charging & discharging characteristics (Graphs from the OEM).
6. Backup time: Minimum 15 minutes (at the End of Life (EOL) of Battery) for 100 % load with each UPS system
7. Charging Voltage Float: 2.23-2.27 V per Cell at 27°C
Boost: 2.28-2.32 V per Cell at 27°C
8. Cutoff Voltage 1.70-1.75 V per Cell (should be Selectable)
9. Floating Voltage regulation between no load & full load. 1% or better.
10. CODES & STANDARDS The supplying battery manufacturer shall be ISO 9001/14001 certified. The battery design shall be of proven technology. The manufacturer shall have 5 years of field experience. ISO-9001/14001. Copy of Certificate for 'VRLA Battery' must be attached with the offer.
11. DESIGN All cells within the battery string shall be of the same

- manufacturer and model. The cells shall be “valve-regulated” (maintenance free) type.
12. Life
20 years designed life at 27 degrees C on full float.
 13. Life Cycling Characteristics
Each battery shall be designed to provide 4000 cycles at 20% depth of discharge (DOD) at 27 degrees C and 1200 cycles at 80% DOD at 27 degrees C..
 14. Deep Discharge
Following an equalization charge, battery shall be capable of being recharged to rated capacity from a discharge down to zero volt per cell.
 15. Recharge Rate
The battery shall be capable of a 90% recharge within 12 hours
 16. Operating Temperatures and altitude
The battery shall be capable of operating in temperatures ranging from 0°C to +40°C. Battery shall withstand hard freezing without damage to the alloy, plates, or cell container assembly. The battery shall be capable of operating at a maximum of 3000m from ground level (AMSL).
 17. Gassing
No special ventilation shall be required under normal operating conditions. No separate “battery room” shall be required to house the battery unit.
 18. Battery Orientation
Battery bank shall have clear removable covers to facilitate visual inspections and allow ease of service.
 19. Self-Discharge
The battery shall have a maximum self-discharge rate of 0.5-1.0% per week at 27°C.
 20. Construction/
Functional Description
Pressure Relief Valve
Each cell shall have a self re-sealing pressure regulation valve, which operates at specified pressure. A flame arrester shall be incorporated in the valve designed to diffuse the Hydrogen gas escaped during charge and discharge. The valve shall be such that it cannot be opened without a proper tool. The valve shall be capable to withstand internal cell pressure specified by the manufacturer.
 21. Housing
The Battery system should be installed & supplied with M S Racks. There should be wire mesh cage to prevent accidental human contact.
 22. Product Identification Label
Each battery shall have a self-adhering label identifying the product manufacturer, model and nominal Amp/Hour capacity. The label must be readily visible from the front of the battery. The label shall not wear out throughout the life of the battery.
 23. ATP
Acceptance Test Procedure should be provided with the offer.
 24. Capacity Testing
Each cell shall be capacity tested at the manufacturing facility as per standard battery testing procedure. For each battery, battery performance tables and curves shall be submitted with the supply. The curves may be obtained by test or by calculation.

25. Leak Detection Integrity of the container and post seals shall be verified in the cell manufacturing process using an automated helium leak detection process.
26. Seismic Requirements Cells shall be packaged in steel modules that meet Seismic requirements when stacked horizontally.
27. Accessories Each battery shall be furnished with the following accessories:
1. Each battery system shall include the necessary inter-cell and inter-module connectors and terminal plates. The connectors shall be lead-tin plated copper and shall include stainless steel hardware.
2. One set of numerals (one numeral per cell) suitable for permanent attachment to cells.
3. Assembly and connection drawings.
4. Each module shall include an easily removable transparent “snap on” safety shield to cover all connectors
28. Recycling services The manufacturer must provide worldwide recycling services to properly dispose of spent lead-acid batteries. These services must include proper instructions for the packaging, transportation, and beneficial recycling as required meeting E.P.A. guidelines (or other applicable agencies) for the safe handling of lead-acid batteries. Documentation of disposal must be provided.
29. Max. Battery Charging current with nominal load To be specified
(Battery charging current should be selectable from the front panel of UPS system upto above maximum value)
30. Warranty The battery system should have warranty for 36 months from date of installation or 39 months from the date of dispatch which ever is earlier.
31. The bidder should submit battery sizing calculation justifying following points:
- No. of Cells
 - Capacity of Cell (Ah), (By considering the K factor, efficiency of system, Temperature correction factor, Ageing correction factor, etc.)
 - DC bus voltage
- The total required area for battery installation should also be mentioned.

4 E.ISOLATION TRANSFORMEER

The Isolation Transformer should be Three Phase, Naturally air cooled type, Housed in one steel cubical provided with cast iron wheels at bottom and should have Hooks for lifting the unit. The cubical enclosing the Isolation Transformer should have sufficient openings (doors and removable covers) for ease of operation and maintenance of the system.

- | | |
|--------------------------------|------------------------------------------------------------------|
| 1. AC Input: | Delta 3-phase, 400±10% (phase to phase) |
| 2. AC output: | Star 3-phase, 400±10% (phase to phase)
230 (phase to neutral) |
| 3. Frequency: | 47 to 53 Hz |
| 4. Capacity: | 60 KVA |
| 5. Duty cycle and use | 24 x7 Continuous, Indoor |
| 6. Common Mode Noise Rejection | Better than 110 dB |
| 7. Inter winding capacitance | Less than 0.005 pF |
| 8. Insulation resistance | More than 500 Mega Ohms at 500V |
| 9. Terminals | Studs on fiber glass plate at rear |
| 10. Cable entry | Bottom |

4 F. ENVIRONMENTAL CONDITION

- | | |
|------------------------------------------|------------------------------------------|
| 1. Operating Ambient Temperature | 0 ⁰ C to 40 ⁰ C |
| 2. Storage/Transport Ambient Temperature | - 25 ⁰ C to 55 ⁰ C |
| 3. Relative Humidity | 90% |
6. **STANDARD TERMS AND CONDITIONS FOR THE COMPLETE OFFER: Please refer Part 1.0.**

6.1 SPARES:

Necessary spares required for the maintenance of the equipment should also be quoted separately. The value of such spares should not exceed 5% of the total cost of the equipment. AIR shall exercise option to order spares.

6.2 ACCESSORIES:

All essential accessories that shall complete the system as desired in “Essential features” (Para 3 of the specification) should be included in the offer.

6.5.1 **Installation Manual:** A detailed installation manual for the installation of UPS System should contain at least the following details:

- a) A floor equipment layout plan with dimensions in meters for installing the UPS System in the hall. All the dimensions of hall with ceiling height, and equipment to be installed should be provided.
- b) Isometric view of UPS System and allied equipment diagrams with dimensions in meters are to be provided.
- c) All installation drawings with dimensions are to be provided.
- d) All mechanical assembly drawings of the UPS System with dimensions are to be provided.
- e) All the views, i.e. Front, rear, top and side, of the UPS System with dimensions are to be provided.
- f) A detailed diagram showing the airflow Inlet to the UPS and the out let route should be provided.
- g) All unpacking/ installing details of the UPS are to be provided.
- h) A detailed write up in English regarding installing the UPS System along with its associated equipment items should be provided.
- i) The procedure of alignment and adjustment of various assemblies, sub- assemblies of UPS System to be described in details in the installation manual.
- j) The procedural details of alignment of all stages, control circuits and input/output stage of the UPS System should be described with practical examples in this manual.
- k) All do's and don'ts which are essential for safe installation of the UPS System should be described in the installation manual.
- l) A detailed description with all relevant circuit diagrams for the control circuit of the UPS should be provided.
- m) The detailed procedure and possibilities of By-passing UPS unit and control circuit should be described with diagrams in this manual.

6.5.2 **Operation and Maintenance Manual:** A detailed operation and maintenance manual with all drawings, circuit diagrams, of all PCB's assemblies, subassemblies are to be provided.

- a) All details regarding putting "ON" with the sequence of operation of the UPS are to be provided in the manual.
- b) The details of all electrical/electronic circuits in various stages of the UPS used along with their write-ups are to be provided in this manual.
- c) All precautions and detailed instructions regarding operation of the UPS System should be provided in this manual.
- d) The detailed description with examples for taking various measurements with the measuring equipment along with the test bench details for measuring various parameters for the UPS should be provided in the manual.
- e) The various tests and measuring equipment required and essential for the routine maintenance and calibration along with the procedure for taking such measurement calibration should be provided in the manual.

- f) The lists of all parts/components/assemblies/subassemblies with their part numbers and with the source of supply with supplier's address etc. are to be provided in this manual.
- g) The details of ordering specifications for all parts / components / subassemblies / PCB / units should be listed in this manual to facilitate reordering of spares as and when required during the life time of this UPS System.
- h) The details of self-check for the UPS System and internal calibration are to be described in the manual.
- i) The detailed procedure for trouble shooting of the UPS System preferably up to component level should be available in the manual. Various test fixtures and accessories required for the maintenance/ repair of the UPS System should be clearly described and detailed out in this manual. The systematic trouble shooting/ fault tree and flow diagram should be provided for diagnosis of the fault with its remedial measures in this manual.
- j) The various assemblies/sub assemblies, PCBs, Parts and Components should be clearly marked to define its functions. The schematic diagrams and references should be described in such a way so that the parts/assemblies/PCBs etc. can easily be identified from the components layout diagram provided in the manual.
- k) All the controls, switches, knobs, interfaces and indications should be clearly marked to show their circuit designation and functions.
- l) Accessibility for testing, replacing of components, ease of maintenance, calibration and adjustment should be the main design features of the UPS System.
- 1. The manual should have description regarding various interfaces, connectors, connecting cables and accessories required for the satisfactory function of the UPS System. All such items required should be provided by the manufacturer along with the UPS system.

6.6 INSPECTION: As per Part 1.0.

6.7 GUARANTEE: As per Part 1.0.

6.8 INSTALLATION AND COMMISSIONING: As per Part 1.0.

FIGURE -1
UPS SINGLE MODULE -SUGGESTIVE
CONFIGURATION

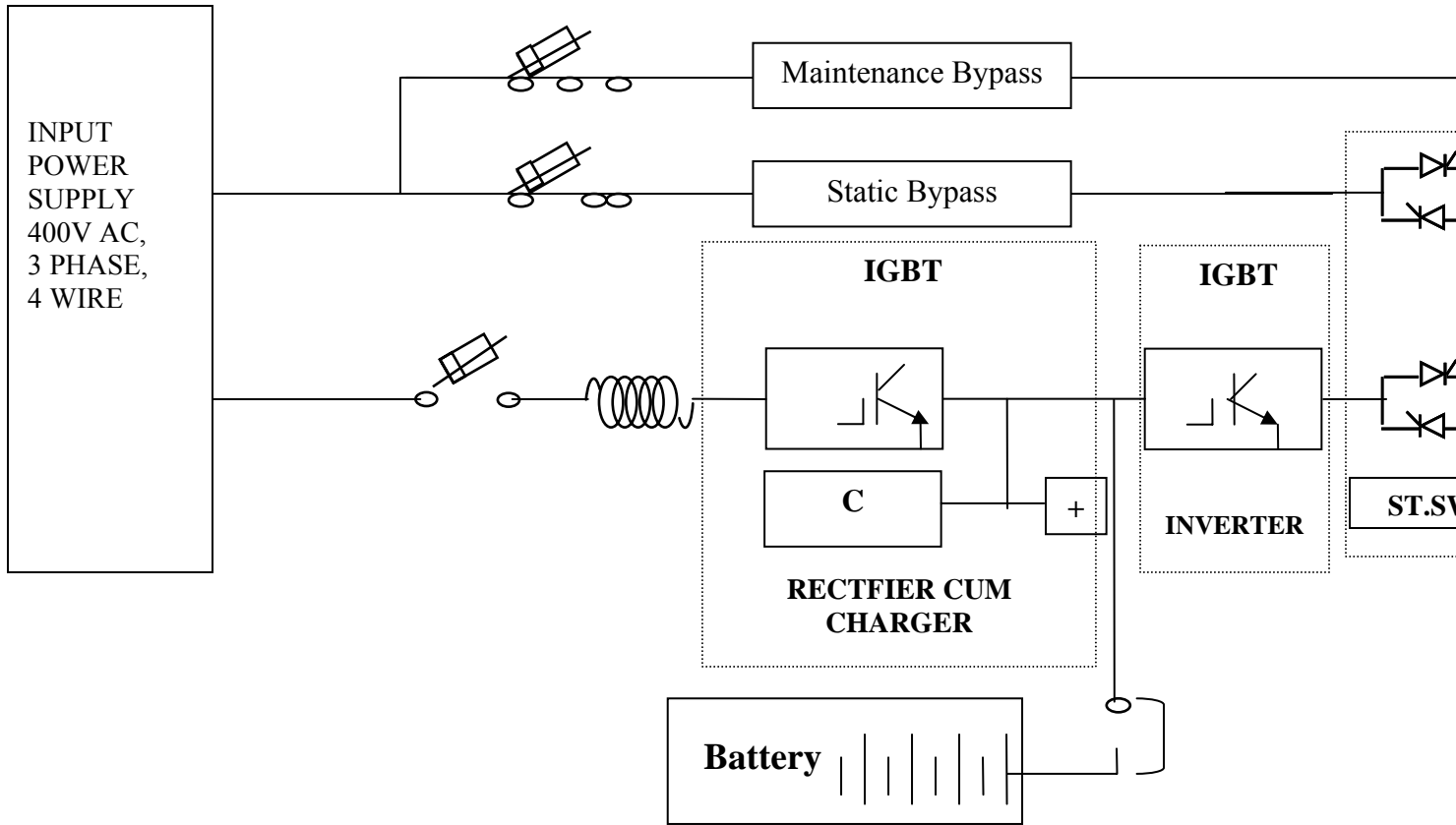

2.9 SETC SPECIFICATION FOR 80 KVA AIR COOLED AUTOMATIC VOLTAGE REGULATOR

General:

The unit shall be self-contained, compact, efficient and highly reliable for 100% duty cycle at full load, working round-the clock, 365 days a year and based on field-proven design using modern technology. All materials used in the construction shall be of high quality and as per relevant Indian Standard Specifications.

Scope: This specification covers the supply of air cooled automatic voltage regulator of 80 KVA capacity 3 phase, 50 Hz for FM transmitter & associated broadcasting equipment in All India Radio.

Clause by clause compliance with the specifications shall be indicated.

Information to be supplied with the tender: Please also refer Part 1.0 &

a) A circuit diagram showing the circuit details of the equipment being offered.

Salient Features

- a) Modular construction of control circuitry for easy replacement.
- b) Control voltage device designed using solid-state electronic circuits.
- c) High-speed step-less correction of output voltage using A.C synchronous motors, without hunting or overshooting.
- d) Independent controls for each of the three phases to avoid unbalance in output load voltage in any phase affecting the output of AVR.
- e) Built-in overload and short-circuit protection.
- f) Should not introduce waveform distortion.
- g) Front access for installation and servicing.
- h) Compact size.(One of the base dimension be restricted to 600 mm.)
- i) Full complement of meters, controls, alarms and indicators.
- j) All moving contacts designed to give long and trouble free service
- k) Rugged construction and field-proven design requiring minimum maintenance . MTBF of the equipment to be specified.
- l) Suitable for continuous use in tropical climatic conditions.
- m) Equipment should have provision for suitable earthing.

25th October, 2010

TECHNICAL REQUIREMENTS

1. Capacity of AVR : 80 KVA (continuous)
2. Input/Output voltage
 - 2.1 Input voltage : 250 V to 460 V A.C Three phase 50 Hz,4 wire
 - 1.2.2 Output Voltage : 400 V \pm 1% A.C Three Phase 50 Hz.(230 volts Phase to neutral),voltage shall be adjustable to \pm 5% with control located on front panel.
 - 1.2.3 Voltage Regulation : \pm 1% from no load to full load.
 - 1.3 Frequency : AVR should work satisfactorily with input frequency range of 50 Hz \pm 6%
 - 1.4 Distortion : It should not introduce any output distortion.
 - 1.5 AVR Type : Indoor, free-floor standing, servo-controlled or any Other state-of-the –art technology (sensing and control Details to be indicated) with individual phase sensing and control for regulating unbalanced incoming voltage and suitable for unbalanced loads. The unbalance in load can be of the order of 50% of rated load. The output voltage stability with this unbalance (up to 50%) should be within \pm 5% of the Nominal output voltage.
 - 1.6 Speed of correction : Details to be given by Tenderer.
 - 1.7 Efficiency : The efficiency of AVR shall be 95% or better
 - 1.8 Transformer Winding : Electrolytic prime grade copper.
 - 1.9 Insulation Class : As per IS amended up to date
 - 1.20 Insulation level rated short Duration power fluctuation Withstand voltage : As per IS amended up to date
 - 1.21 Metering & indications :
 - i) Digital meters shall be provided with selector switches for measurement of Phase to Phase & Phase to Neutral voltage on all three phases for Input and Output.
 - ii) Digital ammeter in output on all three phases.
 - iii)Indications, on control panel shall be provided for input/output voltage status.

- 1.22 Standby Manual : Facility should also be available to use AVR as a simple manually operated voltage regulator in case of failure of automatic control system. Selector switches for selection of mode of operation (AUTO/MANUAL) and other necessary control switches for this purpose may be provided on the front panel.
- 1.23 Type of Cooling : Natural air Cooled
- 1.24 Electrical Protection : AVR shall be protected against over loads, short-circuit surge voltage due to system faults, switching Operations, and hotspot temperature. Complete details of protections(standard as well as optional) are to be Furnished with the tender. MCCB of reputed makes (Siemens/L&T/EE only) are to be provided at the INPUT/OUTPUT.
- 1.25 Main Selector Switch : A four-position heavy-duty control switch shall be Provided for the following operations:
- a) OFF : The input supply is cut off.
- b) TEST : Input supply is through but output is cut off.
- c) ON : Input and output both are through.
- d) BY-PASS : AVR gets isolated and the input gets directly connected to output.
- 1.26 Working Temperature : AVR shall work satisfactorily under ambient Temperature of 0-45 deg.C. and relative humidity of 95% non-condensing at 80 deg C.
- 1.27 Time-Delay Switching : An adjustable time delay device shall be provided so
That the output is connected to load about 15 to 30 seconds(adjustable) after the input is/switched on/ restored after Power Supply failure or momentary interruption during which period the AVR output voltage will stabilize to the desired pre-set value.
- 1.28 Designation Labels : Suitable designation labels for all controls etc. shall be engraved on the panel and shall be distinctly visible .

- 1.29 Connections : Star with insulated neutral.
- 1.30 Terminal arrangement : Cable end boxes for input & output to be provided for upto 3 ½ core 185 sq.mm LT cable
- 1.31 Temp. Rise : To be indicated
- 1.32 Over Load Capacity : Details to be given by Tenderer.
- 1.32 Component Loses
- a) No load loss (Watts) at 800V & 50 Hz frequency : To be indicated by Tenderer.
- b) Max.loss(W) at full load current at winding temp. of 75 deg. C and 800 V & also at 380V (Phase to phase input voltage) : To be indicated by Tenderer.
- 1.33 Approximate weight
- a) Core & Windings : To be indicated by Tenderer.
- b) Tank fittings and accessories
- c) Total weight in Kg.
- 1.34 Overall Dimensions : To be indicated
- a) For AVR
- b) For Control Panel
- c) One of the base dimensions should be restricted to 1000 mm.
2. MECHANICAL CONSTRUCTION
- 2.1 Enclosure : The body of AVR shall be made of MS sheet of finimum 16 SWG thickness capable to with stand transit hazards and to provide mechanical protection to the sensitive parts
- 2.2 Facility for movement : The AVR will be provided with sturdy wheels for ease of movement.
- 2.3 Outer Finish : First quality paint after the initial primer coat shall be used to prevent rusting, corrosion etc.
- 2.4 Technical Literature : Two sets complete with circuit details.
3. Accessories :All the accessories like earthling terminals, lifting hook, terminal marking plate, diagram plate, rating plat, etc. as may be required for installation, operation & maintenance shall be supplied along with the AVR.

Optional accessories, if any, may be quoted separately.

2.10 SETC OF AIR COOLED 80 KVA ISOLATION TRANSFORMER

General:

The unit shall be self-contained, compact, efficient and highly reliable for 100% duty cycle at full load, working round-the clock, 365 days a year and based on field-proven design using modern technology. All materials used in the construction shall be of high quality and as per relevant Indian Standard Specifications.

Scope: This specification covers the supply of air cooled Isolation transformer of 80 KVA capacity 3 phase, 50 Hz for FM transmitter & associated broadcasting equipment in All India Radio.

Information to be supplied with the tender: Please refer Part 1.0 &

- a) A circuit diagram showing the circuit details of the equipment being offered.

Salient Features

- a) Very high common mode noise rejection.
b) No waveform distortion.
c) Front access for installation and servicing.
d) Compact size (One of the base dimension to be restricted to 1000 mm)
e) Rugged construction and field-proven design requiring minimum maintenance. MTBF of the equipment to be specified.
f) Suitable for continuous use in tropical climatic conditions.
g) Equipment should have provision for suitable earthing.

1. TECHNICAL REQUIREMENTS

- 1.1 Rating & type of cooling : 80 KVA, air-cooled Isolation Transformer
1.2 Input voltage : 400 volt +/-10% 50 Hz, 3Ph 4 wire AC
1.3 Output voltage : 400 volt +/-10% 50 Hz, 3Ph 4 wire AC
1.4 Transformation ratio : 1:1
1.5 Coupling capacitance between primary and secondary windings : Details to be given by Tenderer.
1.6 Mutual coupling(Phase to phase Isolation) : Details to be given by Tenderer.
1.7 D.C.insulation from primary to secondary or between any winding and ground : 1000Mega Ohm at 500 Volt
1.8 Common mode noise rejection : Details to be given by Tenderer.
1.9 Breakdown voltage : 2.5 KV A.C for 2 minutes
1.0 Line frequency : 50 Hz +/-6%
1.11 Output waveform shall conform to the input-waveform without : Details to be provided by the tenderer.

25th October, 2010

any distortion over the entire operating power range

- 1.12 a) Electrical protection : It shall be protected against over loads, short-circuit, surge voltage due to system faults, switching operations and hot spot temperature. Complete details of protections (standard as well as optional) are to be furnished with the tender. MCCB of reputed makes (Siemens/L&T/EE only) are to be provided at the INPUT/OUTPUT.
- b) Terminal arrangement : Cable end boxes to be provided for up to 3-1/2 core, 185 sq.mm LT cable. Two cables will be connected for both input/output connections
- 1.13 Working temperature : The equipment shall work satisfactorily under ambient Temperature of 0-45 degree Celsius and relative Humidity of 95% non-condensing at 80 degree Celsius
- 1.14 Terminals : Brass terminals of adequate rating.
- 1.15 Overall Dimensions : To be indicated.
- 1.16 Insulation class : As per IS amended up to date
- 1.17 Over Load Capacity : Details to be given by Tenderer.
2. MECHANICAL CONSTRUCTION
- 2.1 Enclosure : The body of Isolation Transformer shall be made of MS sheet of min. 16 SWG thickness. The enclosure Should be capable to withstand transit hazards and to provide mechanical protection to the parts.
- 2.2 Facility for movement : The unit will be provided with sturdy wheels for ease of movement.
- 2.3 Outer finish : First quality paint after application of primer shall be used to prevent rusting, corrosion etc.
3. TECHNICAL MANUALS : Two sets each of instruction and service manuals are to be included in the offer.
4. ACCESSORIES : All the accessories like earthing terminals, lifting hook terminal marking plate, diagram plate, rating Plates etc. are to be provided. Installation, operation and Maintenance manual shall be supplied alongwith the Isolation Transformer. Optional accessories, if any, may be quoted separately.

2.11 SETC OF VENTILATION EQUIPMENT

SPECIFICATION OF SETC OF VENTILATION EQUIPMENT SPLIT TYPE (REVERSABLE)

Sr.no.	Technical description	Technical Parameter
	Cooling	1.5 TR at 27°C
	Heating Capacity	2 KW
	Operating Voltage	Single Phase as per Part 1.0
	Power Consumption	Preferably five star for better efficiency
	Supply Air	550 CFM
	Protections	Refrigerant High Pressure Refrigerant Low Pressure Over heat for Heaters Heating / Cooling Thermostat Time Delay Relay Overload for Motors
	Controls	(a) ON/Off (b) Heat (c) Cool (d) Ventilation (through independent fresh air fan)
	Motor	The Motors should be as per IS Standard.
	Wiring	All the Electrical Wiring shall be to PTFE and Conform to relevant IS Specification.
	Construction	The Sheet Meet Parts shall be made of heavy gauge steel sheet and passivated and painted with polyurethane paint in matt finish. The Condenser unit shall be mounted outside the Room/ Shelter on a bracket with suitable anti vibration mounting. Room / Evaporator Unit shall be mounted inside the room at a suitable location with the necessary brackets. The inter connection copper pipes between indoor and outdoor unit shall be routed and secured in such a way to avoid vibrations or leakages of refrigerant. All the fasteners shall be of Stainless.Steel. to avoid corrosion.
	Noise Level	The AC shall confirm to permissible noise level as per IS: It shall also meet the specified limits.
	Air Filters	Synthetic fiber or wire mesh filters shall be provided on the inlets of evaporator coil and fresh air. The filters will be easy to remove and re-useable.

2.12 POWER SUPPLY LT BOARDS & EARTHING SYSTEM

(A) SPECIFICATION FOR SITC OF L.T. SWITCH BOARD FOR INDOOR INSTALLATION

1.0 General:

- 1.1 This specification covers design, supply, installation, testing and commissioning of cubicle type sheet steel switch board suitable for 400volts, 3 phase, 4 wire 50 Hz. Power supply with input power factor of 0.80 lagging.
- 1.2 The general power supply schematic and electrical arrangement are shown in the P/S schematic. The switch board will be installed indoors. It shall however be suitable for working under tropical conditions with ambient temperatures up to 50°C and with humidity going up to 95%.
- 1.3 The switchboard shall be designed for efficient and trouble free service for long period of continuous operations. All materials used in the construction shall be of high quality and conform to the relevant IS specifications.
- 1.4 All Electrical work shall be carried out in accordance with standard electrical practice. The units shall be designed for economical and compact accommodation of the necessary, MCCBs and MCBs, for easy maintenance and complete safety to operating personnel.
- 1.5 The L.T. switch board shall be complete with interlocking arrangements, safety shutters wherever required, small wirings, earthing strips, digital meter and the connections, cable compression glands and all accessories for installation and normal service. The design and construction of the switch board and switch gear shall conform to relevant IS standard.
- 1.6 The switchboard offered shall be capable of with standing rigorous use and of resisting rough handling during transport. Adequate lifting facility shall be provided for the complete equipment.
- 1.7 The successful tenderer will have to get the switch board inspected by a person authorized by indenter at site.

2. DETAILED TECHNICAL SPECIFICATIONS;

2.1 GENERAL:

- 2.1.1 The low tension switch board shall be suitable for working on 400 V +/-15% 3 phase, 4 wire 50 HZ +/- 6 % with earthed neutral supply system, and for general requirement shall be as per relevant IS standard
- 2.1.2 The switch board shall be indoor type, wall/ floor fixing compact metal clad totally enclosed and readily extensible. The markings and arrangement for switch gear and control gear shall conform to IS standard.
- 2.1.3 The type of enclosure shall provide a degree of protection conform to relevant IS standard. The LT switch board shall be provided with necessary moulded case circuit breaker with Thermal overload and magnetic release. The sub distribution board shall be provided with the miniature circuit breakers.
- 2.1.4 The cubicle type L.T. switch board shall have a fault withstanding capability as per relevant IS standard.

25th October, 2010

2.2. Constructional features :

2.2.1 The switch board shall be designed for floor/wall mounted. Incoming cables will enter the switch board vertically from the below. Switch board shall be provided with removable bottom plates with cable compression glands fixed for aluminum cables. Aluminum crimping type lugs shall be provided to cables. outgoing cables shall be taken from the top of the switch board

2.2.2 The switch board shall be of single front construction and equipments shall be mounted on the front only. The switch board shall have a uniform height & depth throughout its length. Maximum size of LT Board shall be 1500 x 250 x 1200mm (Width x Depth x height). The board shall be installed on the wall. All cable connections shall be accessible from front side.

2.2.3 The switch board shall present a flush appearance and shall be made of 2mm thick (14 SWG) M.S. sheet and shall be free from rust, scales, grease and other foreign matters.

2.2.4 For convenience of operation and ease of cable termination, there shall be adequate gap (minimum 500mm) between the floor level and the bottom most unit.

2.2.5 The frame work shall be rigid and with modular arrangement. The frame work shall house the MCCBs etc. in multi-tier formation. The equipments shall be mounted independent of the back plate and not on the rear surface of the housing.

2.2.6 Each module shall be fitted with individual doors with concealed hinges. All doors shall be held securely against sponge rubber gaskets to make the equipment dust free and vermin proof.

2.2.7 The compartment doors shall be so interlocked that it shall not be possible to open the door with the switch in ON position. Provision may also be made for pad locking the switches in off position wherever required.

2.2.8 All steel work shall undergo a process of degreasing, pickling in acid, cold rinsing, phosphorescing, passivating and then be sprayed with a high corrosion resistant primer. The finishing treatment shall be by application of two coats of heat resistant synthetic enamel of approved shade as per relevant IS standard.

2.2.9 A base channel, painted black shall be provided to prevent corrosion of sheet cubicles and to facilitate cleaning of floors.

2.3. Bus Bars

2.3.1 Single piece, air insulated bus-bars of hard drawn high conductivity copper rated for the current indicated in the reference drawing and corrected for an ambient temperature of 50 C and conforming to relevant IS standard shall be provided.

2.3.2 Bus bars shall be supported on unbreakable, non- hygroscopic supports rigidly held to the frame work of the chamber so as to withstand the dynamic forces during worst fault conditions. These are to be insulated individually with an approved non deteriorating insulating material to make it dust proof.

2.3.3 The neutral bus bars should be insulated with provision for earthing at one point. Minimum clearances of bus bars between phase to phase, between phase and neutral and between phase and earth shall conform to relevant IS Standard.

2.3.4 The bus bars shall have continuous current rating throughout the length of the switch board. The neutral bus bar shall have continuous rating of at least 50% of the phase bus bar.

2.3.5 Red, Yellow & Blue indicating lamps with protective fuses shall be provided on the bus bar chamber to indicate the status of the R,Y,B phase.

2.4 Moulded case circuit breakers: All the MCCBs shall be ISI marked and different current setting for 50 %, 75 % are to be provided by the tenderer.

2.4.1 The operating handle should clearly indicate ON, OFF and TRIP positions.

25th October, 2010

Specification no: SETC-10 KW TX (1+1) Naushera (Mangla Devi Fort) /J&K/ October/ 2010/D (TD/FM)

- 2.4.2 Earth Leakage protection is to be provided with MCCBs for safety of operating personnel. All parts of the circuit breaker shall be enclosed in the moulded housing with only the terminals accessible for external connections.
- 2.4.3 The MCCBs shall be of reputed make such as L&T , Semen's English Electric & Crompton Greaves. Test certificates shall be submitted as per relevant IS standard.
- 2.5 Miniature circuit Breaker (MCB): MCBs shall be ISI marked.
- 2.5.1 The MCB shall be similar to Morarji Dorman (MDS), Crompton Greaves, etc.
- 2.5.2 All the necessary Cable compression glands for the incoming/out going cables will be provided including connections etc. complete as required by the tenderer.
- 2.6 All control and metering wiring shall be done by 1.5 sq.mm (stranded) copper conductor, PVC insulated wire. CTs wiring shall be done with 2.5 sq.mm copper conductors (stranded). All control wirings shall be fitted with identification ferrule at each end duly numbered /identified. The wires shall be arranged and supported in such a manner that there shall be no strain on the terminations.
- 2.7 All the connection / interconnection inside the cubical type LT board shall be of copper conductor strip/solid circular bar/copper conductor (stranded)PVC insulated having rating at least 1.5 times the normal rating. These are to be insulated individually with an approved non deteriorating insulating material to make it dust proof. As per the requirement tenderer shall use suitable copper thimbles of suitable size duly crimped and fitted with nut bolt washer etc. in a neat, clean and in professional manner.
- 2.8 Digital Indicating Instruments: All the meters i.e. voltages of all the three phases, current of all three phases, frequency, and power factor meter shall be digital meters and ISI marked. Current and potential transformer shall be as per relevant ISI standard. Metering shall be provided as per schematic. All the meters shall be digital and flush mounting type.
- 2.9 Earthing: Earthing conductor shall be of aluminium and minimum size as 5 mm x 30mm. The terminals will be provided for connecting the board to external earth through 25 mm wide 4 mm thick copper or G.I. strips.
- 2.10 All the test report of LT board as per relevant IS standard as applicable shall be submitted by the tenderer. All the connections incoming/ outgoing cable shall be done as per the relevant IS standard along with the testing, commissioning of the LT board.
- 2.11 Miscellaneous: In respect of following, the tenderer shall provide and comply in the SITC of the above LT board.
- 2.11.1 All the bus bar shall have colour identification.
- 2.11.2 All the incoming / outgoing MCCBs, MCBs etc. are to be duly marked for proper identification.
- 2.11.3 R, Y, B shall be in colour as well as in single letter form as R, Y, B.
- 2.11.4 All the openings/holes in the LT board should be plugged / covered with the insulating sheet properly.
- 2.11.5 All the tools required for the maintenance should be the part of the SITC of the LT board.
- 2.11.6 Suitable danger notice board with sign of skull and bones with voltage level indication and confirming to the relevant IS shall be affixed on the electrical installations located in the various compartments.
- 2.11.7 The glands of all the incoming/outgoing cables shall be connected with two separate and distinct connections with earth.
- 2.11.8 All the earthing strip wherever continuity breaks shall be got brazed / welded (as the case may be) in addition to their being tightened with nut and bolts.
- 2.12 Two sets of spare fuses and lamps may also be included in the quotations.
- 2.13 Complete schedule of materials of each unit, wiring diagram of the electrical circuit.& exact dimensional details of the equipment offered, its weight, mounting arrangements and minimum clearance required from the walls/floor.
- 2.14 The trip settings of various breakers should be set at site after measuring the operating current values for best safety.

25th October, 2010

QUESTIONNAIRE

The tenderer shall submit the following information with the tender documents.

1. Constructional features of the switch board
 - 1.1 Overall Dimensions of the switch board offered. (Length x Dept x height in mm)
 - 1.2 Number of panels (sketch showing the layout of the various component parts to be enclosed)
 - 1.3 Thickness of the sheet used in mm.
 - 1.3.1 For the front panels
 - 1.3.2 For the back panels
 - 1.3.3 For the side and top panels
 - 1.3.4 For bottom panels/covers
 - 1.4 Material of the sheet used for the switch board.
 - 1.5 Whether anti corrosive primer and heat resistant synthetic enamel paints are used over the cubicle sheet?
 - 1.6 Whether the switch board is provided with removable bottom plates?
 - 1.7 Whether the switch board has been made dust free and vermin proof? Specify the arrangements provided for the same.
 - 1.8 Whether the L.T. switch board is complete with interlocking arrangements.
 - 1.9 Whether the switch board conforms to safety standards and offers high degree of protection to operating personnel as per relevant IS standard and Indian Electricity/CEA rules.
2. Bus bar
 - 2.1 Specify the material of the bus-bar used and the type of insulation provided.
 - 2.2 Specify the size of the bus bars used.
 - 2.3 Whether bus bars are rating are adequate?
 - 2.4 Specify the clearances provided between bus bars.
 - 2.4.1 Phase to phase.
 - 2.4.2 Phase to neutral
 - 2.4.3 Between bus bars and cubicle panels
 - 2.4.4. Specify the material used for supporting the bus bars.
 - 2.4.5. Whether the insulating support is unbreakable and non-hygroscopic ?
 - 2.5 Moulded case circuit Breaker
 - 2.5.1 Indicate the make and type of moulded case circuit breakers used.
 - 2.5.2 Specify the ratings of MCCBs offered.
 - 2.5.3 Whether over current protection is provided on all the three phases and adjustable independently?
 - 2.5.4 Indicate the range of over current protection and short circuit protection.
 - 2.5.5 Similar information in respect of Earth Fault Relay on all the three phases and adjustable independently and indicate the range .
 - 2.6 Sub-distribution Board
 - 2.6.1 Indicate the type and make of MCBDB used and the make/type of miniature circuit breakers housed therein.
 - 2.6.1.1 Whether control wiring and wirings for metering are done with PVC insulated standard copper conductors of required size ?
 - 2.6.1.2 Whether earth fault relays are provided to trip the incoming MCB in case of Earth fault ?
 - 2.6.1.3 Whether all the controls, inter-locking instruments and indicators, as required in our specification, have been provided ?
 - 2.6.1.4 Whether the installation material necessary for mounting the switch board at site have been included and charged for in the offer ?

25th October, 2010

Refer Suggestive drawing no. TP: 15997 for Main LT board and Sub distribution LT boards for 10 kW RadioVHF FM (1 + 1) transmitter. Tenderer are requested to refer to Part 4.0 of SETC for Supply, Laying, installation, Testing and commissioning of various LT Cables at site in ground/ Trench/Air (as the case may be). All the inter connecting copper cables as per Power Supply Schematic part of SETC.

(B) SETC OF EARTHING SYSTEM

- 1.0 As per standard practice and as per site conditions as stipulated in CPWD specification amended up to date and approved by Indenter.
Please refer Drawing NO. TM -15108/3, 15175/2 &15165
 - Copper Grid earthing as per drawing No. TM- 15175/2 for transmitter - 2 Nos, 2x3 Nos. for RF cable for 2x3 earthing kits & 4 Nos. for tower. The value of earth resistance of each earth system shall be less than 1 Ohm.
 - Copper plate earthing as per IS for audio -2 Nos, The value of earth resistance of each earth system shall be less than 1 Ohm.
 - Copper plate earthing as per IS 2 Nos. for power supply equipment LT Boards, A/C plant
 - Copper plate earthing as per IS 10 Nos for DG set 82.5KVA (1+1) & DG set 40KVA (1+1)
- 2.0 2 Nos. of separate & distinct earth for the neutral & the body earth shall be provided for LT board & DG set. The body earth may be common. However, the neutral earthing will be separate.
- 3.0 Total number of earthing may increase / decrease as per site requirement.
- 4.0 Complete earthing system shall include supply of all materials, arranging T&P & labour, installation/ erection, testing, commissioning complete as per site requirement of earthing system.
- 5.0 **Tenderers are requested to quote against the concerned Serial number of earthing Items for the respective Equipment in Part 4.0 of Specification.**

2.13 DSETC OF CONTAINER FOR RADIO TRANSMITTER/ DSETC OF CONTAINER FOR POWER SUPPLY & ALLIED EQUIPMENT SETUP

2.16 (i) SPECIFICATION OF DSETC OF TRANSMITTER CONTAINER/SHELTER FOR HOUSING RADIO & TV TRANSMITTERS INCLUDING HEAT INSULATION, HEAVY DUTY BASE/ FLOORING 1.5 TON /SQM, FLOORING TILES, DOORS , WINDOW, FALSE CEILING, FINISHING, PAINTING (COLOUR & SHADE DESIGNAS PER SITE REQUIREMENT) FINISHING, PAINTING (COLOUR & SHADE DESIGNAS PER SITE REQUIREMENT) & INTERNAL ELECTRICAL WORKS OF LIGHT & POWER, LIGHT & POWER COPPER WIRING. VENTILATION UNITS COPPER WIRING, SWITCHES, SOCKETS, MCBs, , ILLUMINATION FITTINGS, CONTAINER EXTERNAL LIGHTS & GATE LIGHTS FITTINGS, AUTOMATIC FIRE ALARAM SYSTEM ETC COMPLETE AS PER SITE CONDITION

(ii) SPECIFICATION OF DSETC OF **POWER SUPPLY CONTAINER/SHELTER** FOR HOUSING POWER SUPPLY EQUIPMENT UPS , LT BOARDS, INCLUDING HEAT INSULATION, HEAVY DUTY BASE/FLOORING 1.5 TON /SQM, FLOORING TILES, DOORS , WINDOW, FALSE CEILING , FINISHING, PAINTING (COLOUR & SHADE DESIGNAS PER SITE REQUIREMENT) & INTERNAL ELECTRICAL WORKS OF LIGHT & POWER, LIGHT & POWER COPPER WIRING, SWITCHES, SOCKETS, MCBs, , ILLUMINATION FITTINGS, CONTAINER EXTERNAL LOGHTS & GATE LIGHTS FITTINGS, AUTOMATIC FIRE ALARAM SYSTEM ETC COMPLETE AS PER SITE CONDITION

Please refer Lay out of equipment Drawing No.TM-15951 for Radio transmitter container/shelter.

Please refer Lay out of equipment Drawing No.TM- 15952 for Power supply container for Radio transmitters.

Same specification as given below is to be referred for both containers/ shelters for housing transmitter equipment & power supply equipment.

CONTAINER/SHELTER FOR HOUSING RADIO & TV TRANSMITTERS: Tender is required to work out the size as per the lay out of transmitter equipment and tentative dimensions of equipment along with all **Broadcasting, telecasting & O&M requirement** .

CONTAINER/SHELTER FOR HOUSING POWER SUPPLY EQUIPMENT: Tender is required to work out the size as per the lay out of power supply equipment and tentative dimensions of equipment along with all **CEA regulatory O&M requirements**.

2.8.1 Scope: This specification is for design, manufacturing/fabrication, supply, transportation and installation of container/shelter to be installed at various places of Indenter in J&K Site. These shelters are meant for mobile application & should be suitable for transportation through rail, road & air . These are used in the field under sever weather & physical condition. A drawing specific to each shelters / shelter should be submitted by the tenderer. The requirements are as per details mentioned in specification.

2. 8.2 Information to be supplied with the tender: Please also refer Part 1.0 &

a) Layout and construction details of container/shelter including dimensions, weights, overall sizes and photographs of the interior of the container/shelter. This should include tentative accommodation plan with Plan, front elevation, back elevation , side view for each container/shelter separately, failing which the tender shall be considered incomplete and will be liable for rejection..

- b) Complete drawings with a sections, structural details with list of all hardware material as per IS amended up to date of container/shelter separately as per specification are to be submitted with the offer.
- c) Descriptive information giving complete details of container/ shelter offered.

3.0 REQUIREMENTS

3.1 Operating and environmental conditions

The shelter should withstand, without damage, the following environmental conditions and remain fit for its intended use after being exposed to such condition. Some of the stresses may be simultaneous.

3.1.1 Temperature: Please refer Part 1.0.

3.1.2 **Wind** speed: Operational & Survival: Please refer Part 1.0.

3.1.3 Sealing : During storage, transit and operation, the shelter should be rainproof (with the opening fitted with. Shutters as applicable). All exposed seals and edges should be assembled so as not to absorb nor retain humidity.

3.1.4 Electric field : The screening should be sufficiently effective to provide 60 dB minimum electric field attenuation, in the frequency range of 1500 KHz to 1000 MHz.

3.1.5 Atmospheric: It should be able to with stand as site condition.

3.2 Panel construction

The shelter shall be fully enclosed and thermally insulated. All Panels should essentially be free from corrosion, dents scratches and gouges. The facing should preferably made of sheets without joints. These should be flat aluminum alloy sheets, free from corrosion, dents, scratches and other similar defects. The aluminum sheets should not be affected by natural causes like humidity, rain, atmospheric heat and dust. Design of shelter/ container should be withstand the wind speed 198 km/hr.

3.3 Other features

All the joints should provide sealing against ingress of moisture in to the panel and the interior of the shelters. Each shelter should be provided with a main entrance door and an emergency hatch on main door . The door should be made of same material as that of the wall panel. All doors should be with round corner. The electrical continuity between the cabin doors and panel should be ensured by providing RF shielded gasket. The electrical continuity with door open should be ensured by earthing braid.

One safety lock with three key should be supplied with main door, the emergency hatch should be operable from inside by means of special accessory clipped on to the hatch door.

The door locking bar should be possible to the operated by handles provided on both inside and outside handles. The hinge fixing should be done in such that the rigid skids can be replaced by flexible skids when application from outside.

The shelter should be provided with skids which are screwed on to the bottom on the shelter. The pitch of the fixing screws should be such that the rigid skids can be replaced by flexible skids when application so warrants.

The internal and external metallic skin of the panels should be electrically continuous independently and electrically separated from each other except at one point where they are connected together and grounded resulting in double electrically isolated construction.

4.0 CONSTRUCTION REQUIRMENTS

- 4.1 Metal and mechanical Assemblies
Mechanical assemblies should be designed and protected against electrolytic corrosion. Metal parts should bear no marks of corrosion, blisters, chips or scratches.
- 4.2 Nuts and Bolts
The nuts and bolts used should meet the requirements of the ISI standards. Nuts and bolts used should be Either stainless steel or steel hot dip galvanized.
- 4.3 Insulating Materials
The insulating material should be suitable for thermal /heat insulation as per site condition.
- 4.4 The dimensional details, features and special floor/ base load bearing requirements should be capable to bear the load of 1.5T/Sq. M.

5.0: Structure and material:

5.1 Material: All the material used in the construction of the container/shelter will be ISI marked and as per approved structural drawings of the structural design agency/ Institute as mention in 3.2. The material in totality required shall be designed as per site terrain, loading requirement including the factor of safety better than 2 (two) under the worst conditions

5.2 Safety and structural design: The strength of the structure of container/shelter base support, sides wall panels, roof , flooring etc shall be able to withstand wind velocity as mentioned in clause 3.0 as above or as per CPWD/IS specifications as applicable at the site or which ever is higher. Structural design of container/shelter under worst atmospheric conditions and terrain shall be better than 2(two) and shall be got approved from IIT/SERC by the tenderer.

6.0 General:

- (i) Heavy duty Base/flooring
- (ii) Heat Insulation
- (iii) Flooring tiles
- (iv) Doors, windows, false ceiling
- (vi) Finishing, painting (design and shade as per site requirement)
Reference Suggestive drawing No. TM-15951 & TM-15952 like entrance sliding steel door from out side and sliding aluminum gate from inside, Double glass airtight windows of anodized aluminium with aluminum grill along with glass, handle lock, U-channel etc.

7.0 Electrical work:

Electrical fittings and other accessories etc.

The quantities of items may vary as per actual site requirement.

- (i) Recessed type twin fluorescent 4'×40 W, mirror optic decorative fitting
- (ii) Container outside lights/Gate lights
- (iii) MCBs for Light & power installation
- (iv) SP&N, MCBs with industrial socket and metal box with steel frames
- (v) Light points, power points, light sockets etc.
- (vi) Automatic fire alarm system.

Electrical Switch gear etc. along with protection short circuit, over load & earth fault. Rates for above items will be quoted separately item wise by the tenderer.

Electrical Wiring: Light Points wiring, power point wiring ,circuit wiring, submain wiring and wiring for Ventilation equipment shall be carried out with **copper wiring** stranded conductor as per IS/ CPWD specification amended upto date.

8.0 Working and life:

The workmanship of the proposed container structure will have a very good finish and should reflect the skilled workmanship. The life of the structure shall not be less than 50 years. The various tools and miscellaneous items required for the installation of container will be arranged by the tenderer himself. Painting on wall panels, windows etc. of the container will be done by the tenderer with two coats of paint. Paint will be ISI marked. Colour of paint will be decided by zonal office.

9.0 Inspection of site: The container as per the suggestive specification will be constructed by the firm at site. Transportation and other charges for the installation of the container etc. at site are the part of the tender and no extra payment shall be made on this account.

(A) Electrical Installation points details of transmitter container

S.NO.	DESCRIPTION	QUANTITY ^^
1.	5 Amp light point 8 nos,2x40 watt	8 nos
2.	5 Amp plug point 4 nos x100 watt	4
3.	Cabin floodlight points/ gate light 5 nos x 100 watt	5
4.	20 Amp MCB with Industrial Socket including Metal box frame complete for ventilating units.	5

^^ Quantity may vary as per size on container.

(B)Electrical Installation points details of power supply container

S.NO.	DESCRIPTION	QUANTITY^^
1.	5 Amp light point 6 nos,2x40 watt	6 nos
2.	5 Amp plug point 4 nos x100 watt	4
3.	Cabin floodlight points/gate light 5 nos x 100 watt	5
4.	20 Amp MCB with Industrial Socket including Metal box frame complete for Heaters	5

2.14 TECHNICAL MANUALS FOR TRANSMITTERS SETUPS

(A) TECHNICAL MANUALS : As per OEM

PART 3.0

INSPECTIONS:

(A) INSPECTION OF TRANSMITTERS AT TENDERER'S SYSTEM INTEGRATOR WORKS:

The inspection for acceptance of the Transmitters will be carried out at the Tenderer's System Integrator's Works in accordance with Acceptance Test Procedure/Protocol (ATP). All facilities like complete set of measuring instruments, power supply, manual assistance, etc. will be provided by the supplier. Complete details and specifications of the Transmitter will be checked and all parameter values will be measured. Spares will be tested in circuit in the transmitter.

Prior intimation for carrying out Inspection at tenderer's Integrator works is to be given by the tenderer to the Indenter at least 6 weeks in advance. Inspection period will be three days. For AIR inspecting Engineers expenses to & fro air journey, boarding, lodging etc. will be borne by All India Radio.

The complete Acceptance Test Procedure/Protocol (ATP) will be prepared by the Tenderer and submitted to Director Engineering (Proj.), P&D Unit, DG: AIR for approval. This Procedure after modification (if required during the process of approval) shall form the basis for Performance / Inspection Tests to be carried out. ATP will also indicate full details of set up for measuring / testing equipment to be deployed during the Performance Measurement/ Inspection Test at Tenderer's System Integrator's Works.

Testing and measurements of the Radio Transmitters will be carried out at the Tenderer's System Integrator's Works on three phase, 4 wire, 400 Volt (rms) $\pm 10\%$, 50 Hz $\pm 4\%$ power supply available at the Transmitter's input circuit breaker without any outside transformer unit etc. No other voltage will be acceptable to Indenter at the Transmitter's input circuit breaker and failing the transmitter equipment is liable to be rejected. For Radio VHF FM transmitter testing and measurement will be carried at any three frequencies in the VHF band, 88 to 108 MHz with out tuning/ change of components.

The technical facilities/ equipment for varying within $\pm 10\%$ of three phase ,4 wire, 400 Volts(rms) should be available at Tenderer's System Integrator's Works for Testing , measurements and operation checking of the Transmitter during the inspection.

The performance of transmitter as per parameters in Part 2.0 shall be guaranteed without degradation with the given power supply tolerances.

Complete set of instruments will be made available in advance and the list of these measuring instruments along with their set ups may be forwarded along with the Tender.

Tenderer shall arrange for the photographs of inside of Transmitter's cubicle which will be attached with the ATP/Inspection report.

Exhaustive checking and measurements will be carried out so as to completely check the complete compliance of all equipment as per Part 2.0 of technical specification with the requirements as projected in the specifications. The measurements must be submitted to AIR in advance. The measurement details must be available at the tenderer works at the time of inspection.

It is mandatory that all these testing and measurements i. e. Operation checking of the Transmitter and measurements as per parameters in Part 2.0 at any three frequencies in the VHF band, 88 to 108 MHz without tuning/change of components, are carried out well in advance. These must also be submitted to Indenter

25th October, 2010

Specification no: SETC-10 KW TX (1+1) Naushera (Mangla Devi Fort) /J&K/ October/ 2010/D (TD/FM)

along with the call for inspection of Transmitter well in advance for analyzing etc. Transmitter will be tested for “heat run” for at least 24 hours of continuous operation on full rated power output.

These measurements details, graphical printout notes and figures must be available, at the Tenderer’s System Integrator’s Works at the time of inspection.

Following information should also form part of above data which will also be checked for each Tx during inspection by indenter’s representative at Tenderer’s System Integrator’s Works:-

- A-1.0 Make, type, model no and country of origin & name all units of Transmitter, other items & the accessories, and spares.
- A-2.0 Dimension of Transmitter rack, Sub-Units and Accessories, other items & the accessories .
- A-3.0 Working/operation of all Sub-Units and Accessories.
- A-4.0 System configuration check and completeness of Transmitter.
- A-5.0 Automatic changeover of Exciter and IPA (if applicable) etc.
- A-6.0 Working of Transmitter units after removing them outside the Transmitter rack.
- A-7.0 Checking meter readings and calibration.
- A-8.0 Measurements of all parameters as per specification. All the parameters will be measured on any 3 different frequencies in VHF FM band (88MHz to 108MHz) for Radio VHF FM transmitter. For TV as per part 2.0.
- A-9.0 Checking of control and protection system of Transmitter.
- A-10.0 Checking of all power levels, meters, LEDs etc.
- A-11.0 Checking of RF voltages on test points.
- A-12.0 .Inter-changeability of PAs, sub-modules and PCBs .
- A-13.0 Exciter operation, checking and measurements.
- A-14.0 Working of Exciter in all mode as per Specification including Modulating inputs as per specification :
- A-15.0 Measurement of levels in the whole AF and RF chain.
- A-16.0 Checking of all spares, PCB’s, modules for the respective transmitter, other items & the accessories .
- A-17.0 Measurements of all parameters as per specification. All the parameters will be measured in respect of other items & the accessories

(B) INSPECTION OF ACCEPTANCE OF ASSOCIATED EQUIPMENT, ITEMS & ACCESSORIES AS PER OEM’s TEST CERTIFICATES AT TENDERER’S SYSTEM INTEGRATOR WORKS:

All other associated equipment, items and accessories will be accepted on the basis of Original Equipment Manufacture’s (OEM) Test Certificates (as per Indenter Specification) duly signed and stamped on the letter head of the OEM, failing which Original Equipment Manufacture’s (OEM) Test Certificates will be considered incomplete and equipment offered by the firm is liable to be rejected.

OEM test certificates duly stamped and signed by OEM in respect of all equipment as per Part 2.0/Part 4.0 are to be submitted by the tenderer to the indenter before giving call for inspection.

**(C) INSPECTION: Joint Inspection of the setup at site:
AS PER PROFORMA FOR CHECKING VARIOUS POINTS DURING JOINT INSPECTION OF ABOVE SET UP**

25th October, 2010

- (i) Performance measurement will be carried out during Joint inspection in respect of Transmitter equipment, DG sets and UPS at **site** as per OEM test certificate duly stamped and signed by OEM.
- (ii) All other associated equipment, items and accessories will be accepted on the basis of Original Equipment Manufacture's (OEM) Test Certificates (as per Indenter AIR Specification) duly signed and stamped on the letter head of the OEM, failing which Original Equipment Manufacture's (OEM) Test Certificates will be considered incomplete and equipment offered by the firm is liable to be rejected.
- (iii) OEM test certificates in respect of all equipment are to be submitted at site during joint inspection.

PROFORMA FOR CHECKING VARIOUS POINTS DURING JOINT INSPECTION OF ABOVE SET UP ON TURN KEY BASIS AT SITE:

RADIO 10 kW FM (1+1) TRANSMITTER SETUP.

STATION :
TRANSMITTERS MAKE :
TRANSMITTER POWER : KW
FREQUENCY OF OPERATION :
DATE OF JOINT INSPECTION :

1.0 TRANSMITTER CONTAINER MISC. WORKS

- 1.1 Whether flooring, false ceiling etc has been done as per specification :
- 1.2 Whether painting and finishing has been done properly :
- 1.3 Any shortcomings noticed and comments, if any for improvement /modifications. :
- 1.4 Whether any sign boards are displayed at transmitter ? :
- 1.5 Comments on topography of site & its surrounding area affecting the coverage. :
- 1.6 Pending works / defects, if any. :
- 1.7 Are the rating of switches :

25th October, 2010

- and cables adequate or the change over arrangement adequate?
- 1.8 Any other comments on power supply? :
- 2.0 82.5 KVA (1+1) & 62.5KVA(1+1) DIESEL GENERATOR WITH REMOTE CONTROL :
- 2.1 What is the capacity of Diesel Generators provided? :
- 2.2 Is the capacity of diesel generator adequate as per site condition? :
- 2.3 Are the changeover arrangements adequate? :
- 2.4 Any operational difficulty? :
- 2.5 Is the lay out of Diesel Generator and control panel satisfactory
- 4.0 TRANSMITTER EQUIPMENT :
- 4.1 General layout of equipment : in transmitter Container. Comments for improvement / modification if any.
- 4.2 Inspection of wiring , trays, trenches & conduits, and racks , wall openings, Fouling of openings Inlet or outlet for cables. :
- 4.3 Inter cubicle wiring and termination; dimensions and sizes, General get up. :
- 4.4 Working of safety devices & interlocks, both for the safety of equipment and personnel to be checked up. :
- 4.5 Whether circuit modifications suggested from time to time have been carried out? :

25th October, 2010

- 4.6 Performance of the transmitter regarding frequency response, distortion and noise level to be checked. Highlight the remarks if any. :
- 4.7 Comment on performance of other equipment such as. :
- 4.7.1 RF switch and auto change over switch :
- 4.7.2 Dummy load :
- 4.7.3 Power distribution board :
- 4.7.4 40 KVA UPS :
- 4.7.5 80 KVA AVR :
- 4.7.6 80 KVA Isolation Transformer :
- 4.7.7 Dehydrator :
- 4.7.9 Note & record the panel meter reading of transmitter and of other auxiliary equipments. Highlight the abnormality if any. :
- 4.7.10 Perform functional checks as specified in the A.T.P. of transmitters. Highlight the abnormality if any. :
- 4.7.11 Frequency deviation capability to be checked up. :
- 4.7.12 Setting and working of the audio & power limiting amplifier / audio processor to be checked up. :
- 4.7.13 Whether audio chain has been aligned :
- 4.7.14 Working of stand by exciter units. :
- 4.7.15 Working of VSWR protection. :

25th October, 2010

- 4.7.16 Setting and working of UPS :
- 4.7.17 Whether endurance test has been satisfactorily carried out ? :
- 4.7.18 Whether frequency has been checked and found within tolerance limits. :
- 4.7.19 Inspection of transmitter Blower units and their satisfactory working. :
- 4.7.20 Whether facilities for RF monitoring of programmes have been wired properly? Check its working. :
- 4.7.21 Any other comments? :
- 5.0 FEEDER AND ANTENNA SYSTEM :
- 5.1 Whether RF feeder cable has been properly installed as per instructions? :
- 5.2 Is construction of feeder tray satisfactory? :
- 5.3 Whether the tower has been properly erected & painted according to international practice? :
- 5.4 Whether tower foundations have been properly cast? :
- 5.5 Checking of verticality for the tower. :
- 5.6 Whether tower legs have been properly earthed.
- 5.7 Whether lightning arrestor :

25th October, 2010

have been provided.

- 5.8 Inspection of aviation lights and sun switch , if provided. :
- 5.9 Whether tower base has been leveled properly? :
- 5.10 Whether antenna and power divider has been erected properly and on the correct face? :
- 5.11 Is the arrangement for cable route satisfactory? :
- 5.12 Whether distribution cables have been clamped properly? :
- 5.13 Whether feeder cable is obstructing movement of Vehicles? :
- 5.14 Is the VSWR Antenna & cable? within limit? :
- 5.15 Whether cable and antenna have been pressurized as envisaged. :
- 5.16 Check the frequency of operation of dehydrator to maintain cable pressure? :
- 5.17 Whether extra loop of cable has been done properly? :
- 5.18 Whether any sharp bends are noticed? :
- 5.19 Whether ladder hoops and guard all have been provided? :

25th October, 2010

5.20 Pending work/ defects, if any,

6.0 AIR-CONDITIONING AND VENTILATION:

6.1 What is the arrangement for cooling the transmitter equipments? :

6.2 Whether the arrangement is adequate? :

6.3 Comments on general get up of the inlet & exhaust ducts of transmitter. :

6.4 Is the exhaust blower provided for exhaust duct? :

6.5 Air flow and temperature measurements to be recorded at the inlet & outlet ducts of transmitter. :

6.6 Suggestions for improvement, if any,

7.0 EARTHING :

7.1 Whether earthing has been done as per drawing? :

7.2 How many number of earth pits have been provided? :

7.3 What is the earth resistance ohm value obtained? :

7.4 Whether earth pits have been constructed properly & arrangement for water filling has been provided? :

8.0 RECEPTION SURVEY :

8.1 Whether any field strength measurements listening tests have been carried out? Field strength at 1KM distance & listening test :

8.2 Whether the coverage of transmitter with 48 dBu (Mono) and 54 dBu (Stereo) has been surveyed? :

25th October, 2010

- 8.3 Reading to be recorded
- 8.4 Reports of interference noticed to other services if any.
- 9.0 Checking of Tx. and associated equipment setup along with performance with UPS, AVR, Isolation Transformer, DG Set.
- 10.0 GENERAL :
- 10.1 Check the receipt of all technical manuals & pamphlets, booklets drawings pertaining to installed equipment.
- 10.2 Check the availability of spares for equipment with storage facilities.
- 10.3 Whether the tools and measuring equipments have been received?
- 10.4 Brief of the faults, problems observed during installation.
- 3.0 Miscellaneous
- 3.1 Warning signs, Danger signs displayed at suitable place.
- 3.2 Whether first-aid box available & properly installed.

PART 4.0

SCHEDULE OF SCHEDULE OF REQUIREMENTS / MATERIALS (UN PRICED) for Supply, Erection, Testing and commissioning (SETC) of containerized 10 KW (1+1) VHF FM Transmitters, 10 KW (1+1) UHF TV Transmitters and their auxiliary equipment setup, antenna system in J&K at Naushera (Mangla Devi Fort) as per Specification.

{The tenderer must quote all items}

Note: The pre-bid conference will be held on at Hrs. in conference Hall Room No. 346, Directorate General, All India Radio, New Delhi-110001, India.

4.1(A): SCHEDULE OF REQUIREMENTS / MATERIALS (UN PRICED) FOR 10 KW (1+1) MODE VHF FM TRANSMITTER & ACCESSORIES.

S NO.	Description	Unit	Qty
4.1.1	SETC of 10 kW VHF FM (1+1) Solid State Broadcast transmitter using MOSFET technology capable of giving ≥ 10 kW Continuous power complete as per Specification.	Set complete	1 Set Complete
4.1.2	15 kW Dummy Load, 50 Ohm , 3-1/8" EIA flanges including thru line power meter for measuring forward & reflected power along with element 15,000 W and 1,500 W including all accessories , cables complete with Adopter Kit as per specification.	Set	1 set complete
4.1.3	Spare complete set of resistances for Dummy Load for average power rating ≥ 15 kW.	Set	1 Set
4.1.4 (i)	Automatic change over unit for 10 kW FM Transmitters in (1+1) mode hot stand by with automatic control with transmitters control units complete with all accessories as per specification.	Set	1 Set complete
4.1.4 (ii)	Motorized RF co-axial Changeover switch including control panel with 3-1/8" ports & matching flanges for connecting to antenna or dummy load through rigid line complete with all accessories as per specification.	Set	1 Set complete
4.1.5	FM Mono and Stereo Mod Monitor to be used in – tandem with RF amplifier as per specification.	Set	1 Set complete
4.1.6	Complete SETC of Earthing System, Lightning arrestor, feed and accessories for transmitter & associated equipment & separate for audio equipment as per Indenter Specification /IS. The value of earth resistance of each earth system shall be less than 1 Ohm.	Job	4 Jobs
4.1.7	Any other item / accessories for equipment/items at S. No. 4.1.1 to 4.1.7 offered, for the completeness of the system. . Items wise details	Lot	1 Lot

5th October, 2010

- * Exact Length will be as per sites requirement.
- ** Exact sets will be as sites requirement
- # Rate shall be quoted per Item wise per number/per meter/ per job along with each quantity by the Tenderer)
- ## (Item wise details along with each quantity to be given by the tenderer)
- ^ Items are to be supplied by tenderer including lugs, connectors etc
- @ Volume of container/shelter

Specification no: SETC-10 KW TX (1+1) Naushera (Mangla Devi Fort) /J&K/ October/ 2010/D (TD/FM)

	of the offered material (including part number, if any) are to be given by the tenderer.		
4.1.8	Inspection charges as per specification.	Lot	1 Lot

PART 4.1 (B) SCHEDULE OF MATERIAL/REQUIREMENT FOR SETC (UNPRICED) (Stereo FM Digital Audio Broadcast Processor

SNo.	Description	Unit	Qty
1.	SETC of Stereo FM Digital Audio Broadcast processor equipment complete with auto change over unit and all accessories as per Specification.	number	2 Nos. complete
2.	Any other item offered by the firm for the completeness of equipment.(Details to be given)	Lot	1 lot

PART – 4.2 (A) SCHEDULE OF REQUIREMENTS / MATERIALS (UNPRICED) [FOR ONE SET OF SETC OF 16 PANEL VHF FM ANTENNA]

SECTION 5.0 SCHEDULE OF SETC

SECTION 5.1 Schedule of Supply: of 16 panel VHF FM Antenna, RF coaxial cable, Dehydrator, Antenna switch panel/frame & RF coaxial Rigid Lines & Accessories} at Naushera (Mangla Devi Fort)

S. No.	DESCRIPTION	Unit	Qty
1.0	16 Panel VHF FM (Band II) Complete Antenna System broadly comprising of following and in conformity of AIR Specification : (a to f)	Set/System	1 complete System
a.	Power Dividers (As per design of manufacturer)		
b.	Distribution Cables (As per design of manufacturer)		
c.	RF coaxial air dielectric cables /Rigid line with EIA end connector & with complete accessories (As per design of manufacturer)		
d.	Panel reflectors (As per design of manufacturer)		
e.	Dipoles, Horizontal (Numbers as per Specification)		
f.	Dipoles, Vertical (Numbers as per specification)		
1.1	Any other item / hardware etc. offered for the completeness of the above antenna system - 1 lot (Item wise details of the offered item / hardware material etc. shall be given by the tenderer	Lot	1 Lot
2	RF coaxial Feeder Cable air di-electric as per Specification. *Actual length	M	2x170M

5th October, 2010

* Exact Length will be as per sites requirement.

** Exact sets will be as sites requirement

Rate shall be quoted per Item wise per number/per meter/ per job along with each quantity by the Tenderer)

(Item wise details along with each quantity to be given by the tenderer)

^ Items are to be supplied by tenderer including lugs, connectors etc

@ Volume of container/shelter

Specification no: SETC-10 KW TX (1+1) Naushera (Mangla Devi Fort) /J&K/ October/ 2010/D (TD/FM)

	will be intimated at the time of placement of order.		
	Naushera (Mangla Devi Fort) RF cable as per Section 3.2		
2.7	EIA flange connectors	number	4 numbers
2.8	EIA flange Gas Pass connector	number	4 numbers
2.9	EIA flange Gas Barrier connector	number	2 numbers
2.10	Hoisting stockings for each cable as per recommendation of manufacturer.		As per RF cable manufacturer's recommendation
2.11	Earthing kits (3nos of earthing kits for one cable)	numbers	2x3Nos=6 numbers
2.12	Wall gland/ feed through assembly with accessories	number	2 numbers
2.13	Cable clamps with nut, bolt washer(adjustable height)	Set	2x170Sets
2.14	Any other accessories offered for the completeness of the system	Lot	1Lot
3	Dehydrator with tubing and accessories: as per AIR specification.	numbers	2 numbers
4	Antenna Switch Frame/Panel complete as per AIR Specification	Set	1Set
5	Complete Erection material {RF coaxial copper rigid lines & accessories as per AIR Specification as given below		
	Naushera (Mangla Devi Fort) Site		
5.16	3-1/8" RF coaxial copper rigid Line with inners, bullets & insulators	M	12M
5.17	3-1/8" Elbows with inners, bullets & insulators	Numbers	6 numbers
5.18	3-1/8" Couplings with inners, bullets& insulators	Number	10 numbers
5.19	3-1/8" Field Flange with inners, bullets & insulators	Numbers	6 numbers
5.20	3-1/8" to N Test Reducer	Number	1 number
5.21	4-1/2" to 3-1/8" Reducer Adopter	Numbers	3 numbers
5.22	3-1/8" to 1-5/8" adopter/reducer	Numbers	4 numbers
5.23	Hanger for 3-1/8" RF coaxial Rigid Line	Numbers	12 numbers
5.24	Any other accessories offered for the completeness of the system (Items wise details of offered and included material, items & part are to be given by the Tenderer).	Lot	1 Lot
6	Supply of new vertical RF cable tray (on the existing tower) material including supply of complete hardware material and accessories etc. complete as required at site.(tower height as per Section I) No drilling is allowed for fixing tray on the tower. Suitable clamping arrangement may be used.	Job	1 Job
7	Supply of new horizontal RF cable tray material along with MS canopy material as per specification alongwith supply of complete hardware material and accessories etc. as required at site.(Rate per meter shall be quoted by the tenderer. (* ranking purpose, however actual quantity in running length shall be paid to the tenderer by the indenter).	M	30 M
8	Supply of mounting arrangement of 16 panel on the existing tower : Supply of all the supports of hot dip galvanized angle iron rails for the vertical and horizontal supports on the four faces of Tower for the hoisting of 16 panel antenna complete as per AIR specification.	Set/System	1 Set/System complete
9.	Inspection of antenna at tenderer system intregreter works.		1
10.	Supply of earthing material complete for RF cable earth. (2x3 earthing kits to be earthed) as per specification.	Set/System	6 Set/System complete
11.	Supply of earthing material complete for tower as per specification.	Set/System	4 Set/System complete

5th October, 2010

* Exact Length will be as per sites requirement.

** Exact sets will be as sites requirement

Rate shall be quoted per Item wise per number/per meter/ per job along with each quantity by the Tenderer)

(Item wise details along with each quantity to be given by the tenderer)

^ Items are to be supplied by tenderer including lugs, connectors etc

@ Volume of container/shelter

Section 5.3: Schedule of Erection, Testing & Commissioning.

S No.	Description	Unit	Qty
	(New Erection)		
1.	Erection, Testing and Commissioning of 16 panel VHF FM Antenna as per specification on the existing tower in the FM aperture after unpacking, physical checking/ necessary care for the safety of the antenna system like cleaning, ingress of moisture, pressurization etc. at site before Erection in accordance with the Erection manual of the manufacturer along with hauling of the complete panel antenna system	Job	1 Job
2	Mounting arrangement of 16 panel on the existing tower : Fabrication, Erection/hoisting,, fixing ,of all the supports of hot dip galvanized angle iron rails for the vertical and horizontal supports on the four faces of Tower for the hoisting of 16 panel antenna as per AIR specifications.	Job	1 Job
3	Fabrication, Erection/hoisting, fixing ,testing and commissioning of new vertical RF cable tray for RF co-axial cables on the existing tower complete as required at site.(tower height as per Section I) No drilling is allowed for fixing tray on the tower. Suitable clamping arrangement may be used.	Job	1 Job
4	Fabrication, Erection/hoisting, fixing , testing and commissioning of new horizontal RF cable tray for RF co-axial cables along with MS canopy as per specification complete as required at site.(Rate per meter shall be quoted by the tenderer. (* ranking purpose, however actual quantity in running length shall be paid to the tenderer by the indenter).	Job	1 Job
5	5.1 Erection, Testing and Commissioning of new RF Co-axial cables as per specification on the existing tower/Cable Tray.	Job	1 Job
	5.2 Erection, Testing and Commissioning of new Dehydrators with tubing and accessories including making pressurization connections etc. as per specification at site.	Job	1 Job
6	Erection, testing and commissioning of Antenna Switch Frame/Panel as per specification including making various RF co-axial line input/output connections for feeding to the lower and upper half of the 16 panel VHF FM antenna complete as required.	Job	1 Job
7	Any other job offered for the completeness of the system (Items wise details of offered and included material,items& part are to be given by the tenderer)	Job	1 Job
8	Checking of complete set up as above before application of RF power and recording the test and measurement values in the form of graphical printout for necessary reference as per specification technical parameters.	Job	1 Job
9	Testing of the complete RF chain on full RF power with transmitter on the newly installed antenna switch frame/panel, RF cable and 16 panel VHF FM Antenna in three frequencies in the entire frequency range of 88 -108MHz.	Job	1 Job
10	Final Performance Measurements of the complete RF chain i.e. RF cable, antenna switch panel/frame, 16 panel antenna as per specification alongwith graphical printouts of the measurements like VSWR/return-loss - for entire frequency range of 88 MHz to 108 MHz, isolation, horizontal/vertical pattern circulatory for omni-directional pattern. Actual F.S. pattern upto the signal strength of 48 dBu. Including actual F.S. pattern upto the signal strength for 54 dBu, 66 dBu & 74dBu including Field strength at 1KM distance.	Job	1 Job
11.	Erection, testing& commissioning of earthing system complete for RF cable earth. (2x3 earthing kits to be earthed) as per Indenter Specification /IS. The value of earth resistance of each earth system shall be less than 1 Ohm.	Job	6 Jobs
12.	Erection, testing& commissioning of earthing system complete for tower as per Indenter Specification /IS. The value of earth resistance of each earth system shall be less than 1 Ohm.	Job	4 Jobs

5th October, 2010

* Exact Length will be as per sites requirement.

** Exact sets will be as sites requirement

Rate shall be quoted per Item wise per number/per meter/ per job along with each quantity by the Tenderer)

(Item wise details along with each quantity to be given by the tenderer)

^ Items are to be supplied by tenderer including lugs, connectors etc

@ Volume of container/shelter

**Part 4.3 (A): Schedule of requirement for SETC of RN Terminal Equipment with deicing kit & DTH
KU band**

S NO.	Description	Unit	Qty
4.3.1	Supply of;		
4.3.1.1	6.0 Meter Parabolic Dish Antenna along with civil foundation, proper plat form, Earthing System, Lightning arrestor, feed and accessories including cable tray.	Set	1 Set complete
4.3.1.2	LNBC C-Band	number	3 numbers
4.3.1.3	Low loss cable with connectors (length 50M – 2nos) * Exact length will be as sites requirement.	M	2 x50 M*
4.3.1.4	L band line amplifier	number	2 number
4.3.1.5	L band digital receiver	number	4 numbers
4.3.1.6	L band 1:4 Power divider – 2 numbers & L band 1:2 Power divider -- 2 numbers along with other accessories like connectors and integration material.	Set	1 set complete
4.3.1.7	Full size wired rack (42U) with jack strip and tag block including accessories connectors integration material.	number	1 number
4.3.1.8	Stereo Monitoring Amplifier with set of speakers.	Set	1 Set complete
4.3.1.9	Inspection as per approved ATP at site	Job	1Job
4.3.1.10	Deicing kit for 6.0 M, C band Dish	Set	1 Set complete
4.3.1.11	Charges for Erection/Installation, testing & Commissioning of 4.3.1 Complete	Job	1Job
4.3.1.12	Charges for training (optional) for operation and maintenance for 2 days for 4 persons	Job	1Job
4.3.1.13	Spares for heating element for deicing kit	Set	1 Set complete
4.3.1.14	Any other item offered by the firm for the completeness of equipment	Lot	1lot
4.3.1.15	DTH Ku Band		
(i)	Ku band LNBF	Set	1 Set complete
(ii)	240 cm PDA with universal mount	Set	1 Set complete

5th October, 2010

* Exact Length will be as per sites requirement.

** Exact sets will be as sites requirement

Rate shall be quoted per Item wise per number/per meter/ per job along with each quantity by the Tenderer)

(Item wise details along with each quantity to be given by the tenderer)

^ Items are to be supplied by tenderer including lugs, connectors etc

@ Volume of container/shelter

Specification no: SETC-10 KW TX (1+1) Naushera (Mangla Devi Fort) /J&K/ October/ 2010/D (TD/FM)

(iii)	75 ohm Low loss RF cable with F type male connector on both side	M	25 M
(iv)	Digital Set Top Box (STB) with remote control Hand set, power cable , RCA Phone audio cable for the connection between STB modulator output to PI Rack including portable TV Set	Set	1 Set of (1+1) complete
(v)	Any other item offered by the firm for the completeness of equipment	Lot	1lot

Part 4.3(C) SCHEDULE OF REQUIREMENT/MATERIAL (UNPRICED) FOR SETC of EMERGENCY TRANSMISSION FACILITY

S NO.	Description	Unit	Qty
4.3.1.16	SETC OF;		
(i)	Dynamic Microphone AIR as per Specification.	Set	2Sets Complete
(ii)	Professional CD player as per AIR Specification.	Set	2 Sets Complete
(iii)	Any other item offered by the firm for the completeness of equipment.(Details to be given)	Set	1 Set Complete

PART 4.4: (A) SCHEDULE OF MATERIAL/REQUIREMENT (UNPRICED) FOR SETC OF Stereo & Digital programme input cum monitoring rack – for each site)

Sno.	Description	Unit	Qty
4.4.1	Stereo & Digital Programme Input-Cum-Monitoring Rack broadly comprising of following equipment and Items and as per Indenter specification	Set complete System	1 Set Complete System
i	Stereo programme input selector switch (Solid State based)-1No.		
ii	Digital programme input selector switch (Solid State based)-1No.		
iii	Stereo & Digital metering selector(Solid State based) with D/A convertor for stereo & digital Input.-1Set		
iv	Stereo& Digital monitoring selector(Solid State based) with D/A convertor for stereo & digital Input.-1set		
v	Level display unit/bar graph-1No.		
vi	Stereo& Digital Monitoring amplifier-1Set (1+1)		
vii	High quality stereo speaker -1set		
viii	Stereo AF Jack panels of 20 Jacks each (2 sets)		
ix	Digital AF Jack panels of 20 Jacks each (2 sets)		
x	RF Patch panel-1No		

5th October, 2010

- * Exact Length will be as per sites requirement.
- ** Exact sets will be as sites requirement
- # Rate shall be quoted per Item wise per number/per meter/ per job along with each quantity by the Tenderer)
- ## (Item wise details along with each quantity to be given by the tenderer)
- ^ Items are to be supplied by tenderer including lugs, connectors etc
- @ Volume of container/shelter

Specification no: SETC-10 KW TX (1+1) Naushera (Mangla Devi Fort) /J&K/ October/ 2010/D (TD/FM)

xi	Stereo AF patch cords (4 sets) 3' & 6' (2 each)		
xii	Digital Stereo AF patch cords (4 sets) 3' & 6' (2 each)		
xiii	Stereo Distribution Amplifier- 1 no.		
xiv	Digital Distribution Amplifier- 1 no.		
xv	Studio headphone- 4 Sets		
xvi	Power supply cables, audio cables and connectors for each individual equipment and one spare cord- 1 Lot		

PART 4.5: SCHEDULE OF MATERIAL/REQUIREMENT (UNPRICED) OF SETC OF MEASURING EQUIPMENT – for each site)

SN0.	DESCRIPTION	Qty Jammu Region	Qty Srinagar Region	Qty Leh Region
4.5.1	SETC of Computer System,UPS,Printer complete with all accessories as per specification	1Set complete	1Set complete	1Set complete
4.5.2	Digital multimeter with accessories as per specification	1 set complete	1 set complete	1 set complete
4.5.3	Clipon meter complete with all accessories as per specification	1 set complete	1 set complete	1 set complete
4.5.4	Logic probe complete with all accessories as per specification	1Set complete	1Set complete	1Set complete
4.5.5	Frequency counter complete with all accessories as per specification	1Set complete	1Set complete	1Set complete
4.5.6	Digital Radio Receiver AM, FM,SW complete with all accessories as per specification	2 sets complete	2 sets complete	2 sets complete
4.5.7	Antenna tester/site master complete with all accessories as per specification	1 set complete	1 set complete	1 set complete
4.5.8	Audio signal generator & Distortion Analyzer Test and measurement system complete with all accessories as per specification	1Set complete	1Set complete	1Set complete
4.5.9	Field strength meter with GPS , laptop, software and all accessories as per specification	1 set complete	1 set complete	1 set complete

5th October, 2010

- * Exact Length will be as per sites requirement.
- ** Exact sets will be as sites requirement
- # Rate shall be quoted per Item wise per number/per meter/ per job along with each quantity by the Tenderer)
- ## (Item wise details along with each quantity to be given by the tenderer)
- ^ Items are to be supplied by tenderer including lugs, connectors etc
- @ Volume of container/shelter

PART 4.6 SCHEDULE OF REQUIREMENT/MATERIAL (UNPRICED) FOR SETC FOR STAND ALONE SILENT TYPE DIESEL GENERATOR SETS 82.5 KVA (1+1)

SNo.	Description	Unit	Qty
4.6.1	Supply of 82.5 KVA (1+1) at site condition Silent type Diesel Generator Set 415 V \pm 1%, 3 phase, 4 wire, 50 Hz \pm 4% as per Indenter Specification with Engine, Alternator, Control Panel including suitable interconnecting LT cables, Self contained Acoustic Enclosure for ready to use basis with Service tank of minimum 285 ltrs. Capacity with fuel pipe, dial type fuel gauge and complete accessories, battery system, standard tools including anti-freezing arrangement of coolant. ##	Set	1 set (1+1) complete #
4.6.2	Insurance, Loading, Transportation and unloading at site of the above DG set. ##	Job	1 job# (1+1)
4.6.3	Installation, Testing & Commissioning, of the above DG set. ##	Job	1 job# (1+1)
4.6.4	Supply of Fuel (HSD) and Lubricating Oil and other consumables during testing of DG set at Site for 24 Hrs. of IS-10000, Part IX-1980 amended to date. ##	Job	1 job# (1+1)
4.6.5	Charges for getting CEA / State Electricity Board clearance for complete DG set Installation##	Job	1 job# (1+1)
4.6.6	Supply and Fixing of Silencer/ Exhaust pipe (Rate per mtrs length to be quoted)##	M	8 Mtrs.# (1+1)
4.6.7	DG Sets earthing system as per IS complete as required at site. ##	Job	6 jobs#
4.6.8	## Design, supply of material/ switchgear / arranging T&P,labour, erection, testing, commissioning, complete as per site requirement (DSETC) of LT control panel in DG Shed 82.5 KVA comprising of MCCBs for both DG sets, automatic changeover on load switch, contactors, relays etc. (for feeding power Supply to power supply container for Radio transmitters including all cabling, connections with suitable lugs earthing) as per specification complete as required.	Job	1 Job complete #

5th October, 2010

* Exact Length will be as per sites requirement.

** Exact sets will be as sites requirement

Rate shall be quoted per Item wise per number/per meter/ per job along with each quantity by the Tenderer)

(Item wise details along with each quantity to be given by the tenderer)

^ Items are to be supplied by tenderer including lugs, connectors etc

@ Volume of container/shelter

PART 4.7 SCHEDULE OF REQUIREMENT/MATERIAL (UNPRICED) FOR SETC FOR STAND ALONE SILENT TYPE DIESEL GENERATOR SETS 62.5 KVA (1+1)

SNo.	Description	Unit	Qty
4.7.1	Supply of 62.5 KVA (1+1) at site condition Silent type Diesel Generator Set 415 V \pm 1%, 3 phase, 4 wire, 50 Hz \pm 4% as per Indenter Specification with Engine, Alternator, Control Panel including suitable interconnecting LT cables, Self contained Acoustic Enclosure for ready to use basis with Service tank of minimum 120 ltrs. Capacity with fuel pipe, dial type fuel gauge and complete accessories, battery system, standard tools including anti-freezing arrangement of coolant. ##	Set	1 set (1+1) complete #
4.7.2	Insurance, Loading, Transportation and unloading at site of the above DG set. ##	Job	1 job# (1+1)
4.7.3	Installation, Testing & Commissioning, of the above DG set. ##	Job	1 job# (1+1)
4.7.4	Supply of Fuel (HSD) and Lubricating Oil and other consumables during testing of DG set at Site for 24 Hrs. of IS-10000, Part IX-1980 amended to date. ##	Job	1 job# (1+1)
4.7.5	Charges for getting CEA / State Electricity Board clearance for complete DG set Installation##	Job	1 job# (1+1)
4.7.6	Supply and Fixing of Silencer/ Exhaust pipe (Rate per mtrs length to be quoted)##	M	8 Mtrs.# (1+1)
4.7.7	DG Sets earthing system as per IS complete as required at site. ##	Job	4 jobs#
4.7.8	SETC of power supply Cables for DG Sets in 1+1 configuration in side the 62.5 KVA DG Set shed as above as per IS complete with connections with control panel at site complete as required.##	Job	1 job# (1+1)
4.7.9	## Design, supply of material/ switchgear / arranging T&P,labour, erection, testing, commissioning, complete as per site requirement (DSETC) of LT control panel in DG Shed 62.5 KVA comprising of MCCBs for both DG sets, automatic changeover on load switch, contactors, relays etc. (for feeding power Supply to power supply container for ancillary including all cabling, connections with suitable lugs earthing) as per specification complete as required.	Job	1 Job complete #

5th October, 2010

- * Exact Length will be as per sites requirement.
- ** Exact sets will be as sites requirement
- # Rate shall be quoted per Item wise per number/per meter/ per job along with each quantity by the Tenderer)
- ## (Item wise details along with each quantity to be given by the tenderer)
- ^ Items are to be supplied by tenderer including lugs, connectors etc
- @ Volume of container/shelter

PART 4.8: SCHEDULE OF REQUIREMENT/MATERIAL (UNPRICED) FOR SETC OF ON LINE UNINTERRUPTED POWER SUPPLY SYSTEM 40 KVA (UPS)

(Bill of material must be in the format given below for technical and commercial quotes).

Sl. No.	Description	Unit	Qty
	SETC of:		
4.8.1	40 KVA at “site condition” IGBT/PWM connected in redundant parallel configuration based (Rectifier & Inverter), Fully DSP based Double Conversion, On Line UPS system with Isolation Transformer. (3 Phase, 4 Wire, input - 3 Phase, 4 Wire Output) as per specs. ##	Set	1 Set complete #
4.8.2	Maintenance Free VRLA type Battery Bank (1+1) suitable to provide 15 minutes (minimum) + 15 minutes (minimum) backup (EOL) with heating system for batteries, as per specification at “site condition” Minimum Battery Capacity: (45000VAH minimum)## Tenderer to give (i) No. of batteries (ii) Ah of each battery (iii) Size of the battery bank	Number	No. of batteries to be mentioned by tenderer
4.8.3	Remote Status display panel with interface cables.##	Set	1 Set complete #
4.8.4	Any other item required for the completeness of the UPS system.##	Lot	1 Lot#
4.8.5	UPS control panel with MCCB 4 pole along with interconnecting copper cabling including earthing system as per IS complete as required at site.##	Job	1 job# (1+1)

PART 4.9: SCHEDULE OF REQUIREMENT/MATERIAL (UNPRICED) FOR SETC OF 80 KVA AVR

Sl. No.	Description	Unit	Qty
	SETC of:		
4.9.1	80 KVA AVR at “site condition” as per specs.##	Set	1 Set complete #
4.9.4	Any other item required for the completeness of the AVR system. ##	Lot	1 Lot#
4.9.5	AVR control panel with MCCB 4 pole along with interconnecting copper cabling including earthing system as per IS complete as required at site.##	Job	1 job# (1+1)

5th October, 2010

* Exact Length will be as per sites requirement.

** Exact sets will be as sites requirement

Rate shall be quoted per Item wise per number/per meter/ per job along with each quantity by the Tenderer)

(Item wise details along with each quantity to be given by the tenderer)

^ Items are to be supplied by tenderer including lugs, connectors etc

@ Volume of container/shelter

PART 4.10: SCHEDULE OF REQUIREMENT/MATERIAL (UNPRICED) FOR SETC OF 80 KVA ISOLATION TRANSFORMERS

Sl. No.	Description	Unit	Qty
	SETC of:		
4.10.1	80 KVA Isolation Transformer at "site condition" as per specs.##	Set	1 Set complete #
4.10.4	Any other item required for the completeness of the Isolation transformer system. ##	Lot	1 Lot#
4.10.5	Isolation transformer control panel with MCCB 4 pole along with interconnecting copper cabling including earthing system as per IS complete as required at site.##	Job	1 job# (1+1)

PART 4.11: SCHEDULE OF REQUIREMENT/MATERIAL (UNPRICED) FOR DSETC OF VENTILATION EQUIPMENT FOR TRANSMITTERS. (FOR EACH SITE)

S NO.	Description	Unit	Qty
4.11.1.	SETC of 1.5 T, Reversible Type air conditioners complete as per specification. ##	Set	5 Sets complete #

PART 4.12: (A) SCHEDULE OF REQUIREMENT/MATERIAL (UNPRICED) FOR DSETC L.T. BOARDS & LT Cables excluding L.T. control panel & LT Cables inside 82.5 KVA DG Sets (1+1) shed & 62.5 KVA DG Sets (1+1) shed

S NO.	Description	Unit	Qty
i	## Design, supply of material/ switchgear / arranging T&P,labour, erection, testing, commissioning, complete as per site requirement (DSETC) of Main LT board panel in power supply container for feeding power Supply to Radio transmitter & associated equipment including all cabling, connections with suitable lugs earthing as per specification. Reference Suggestive drawing No.TP-15997	Job	1 Job complete #
ii	## Design, supply of material/ switchgear / arranging T&P, labour, erection, testing, commissioning, complete as per site requirement (DSETC) of Sub distribution LT board panel for ancillaries requirement in power supply container including all cabling, connections with suitable lugs earthing as per specification.	Job	1 Job complete #

5th October, 2010

* Exact Length will be as per sites requirement.

** Exact sets will be as sites requirement

Rate shall be quoted per Item wise per number/per meter/ per job along with each quantity by the Tenderer)

(Item wise details along with each quantity to be given by the tenderer)

^ Items are to be supplied by tenderer including lugs, connectors etc

@ Volume of container/shelter

Specification no: SETC-10 KW TX (1+1) Naushera (Mangla Devi Fort) /J&K/ October/ 2010/D (TD/FM)

	Reference Suggestive drawing No.TP- 15997		
iii	## Design, supply of material/ switchgear / arranging T&P,labour, erection, testing, commissioning, complete as per site requirement (DSETC) of Sub distribution LT panel in transmitter container(for feeding power Supply to transmitter & associated equipment from power supply container) in including all cabling, connections with suitable lugs earthing as per specification. Reference Suggestive drawing No. TP-15997		1 Job complete #
iv	## Design, supply of material/ switchgear / arranging T&P,labour, erection, testing, commissioning, complete as per site requirement (DSETC) of Sub distribution LT panel in transmitter container (for feeding power Supply to AC Units from power supply container) in including all cabling, connections with suitable lugs earthing as per specification. Reference Suggestive drawing No. TP-15997		1 Job complete #

PART 4.12: (A) SCHEDULE OF REQUIREMENT/MATERIAL (UNPRICED) FOR DSETC L.T. BOARDS & LT Cables excluding L.T. control panel & LT Cables inside 82.5 KVA DG sets (1+1) shed & 62.5 KVA DG Sets (1+1) shed

S.No.	Description	Unit	Qty
1.	Supplying ,laying/installation, testing & commissioning of 1.1KV grade , aluminum conductor, PVC insulated, PVC Sheathed armoured power supply cable in ground/trench/air including arranging labour, T&P ,supply of complete material sand bricks for laying of power cable including, lugs, connections suitable earthing as per CPWD specifications/IS. 4 numbers x size 3-1/2 Core x 120 sq.mm (supply from State Electricity Board from output of transformer to main LT board) (2numbers spare cables)	M	4x100 M
2.	----do---- 2 numbers x size 3-1/2 Core x 95 sq.mm (supply from 82.5 KVA DG Shed to power supply container) (1numbers spare cable)	M	2x80M
3.	----do---- 2 numbers x size 3-1/2 Core x 70 sq.mm (supply from 62.5 KVA DG Shed to power supply container) (1numbers spare cable)	M	2x 80M

5th October, 2010

- * Exact Length will be as per sites requirement.
- ** Exact sets will be as sites requirement
- # Rate shall be quoted per Item wise per number/per meter/ per job along with each quantity by the Tenderer)
- ## (Item wise details along with each quantity to be given by the tenderer)
- ^ Items are to be supplied by tenderer including lugs, connectors etc
- @ Volume of container/shelter

Specification no: SETC-10 KW TX (1+1) Naushera (Mangla Devi Fort) /J&K/ October/ 2010/D (TD/FM)

4.	----do--- 2 numbers x size 3-1/2 Core x 35 sq.mm (supply from power supply container to transmitter container (1number spare cables) for transmitter equipment	M	2x 40M
5.	----do--- 2 numbers x size 3-1/2 Core x 35 sq.mm (supply from power supply container to transmitter container (1number spare cables) for AC Units	M	2x 40M
6.	----do---- 2 numbers x size 3-1/2 Core x 25 sq.mm (supply from Power supply container to Office block) (1numbers spare cable)	M	2x 40M
7.	----do---- 2 numbers x size 4 Core x 16 sq.mm (supply from Power supply container to Hostel block) (1numbers spare cable)	M	2x 40M
8.	----do---- 2 numbers x size 4 Core x 16 sq.mm (supply from Power supply container to Pump room)(1numbers spare cable)	M	2x 70M
9.	----do---- 2 numbers x size 4 Core x 10 sq.mm (supply from power supply container to Power supply container to 82.5 KVA DG Set shade (1numbers spare cable)	M	2x 70M
10.	----do---- 2 numbers x size 4 Core x 10 sq.mm (supply from power supply container to 62.5 KVA DG Shade (1numbers spare cable)	M	2x 70M
11.	Supplying ,laying/installation, testing & commissioning of 1.1KV grade , copper conductor, PVC insulated, PVC Sheathed armoured power supply cable in ground/trench/air including arranging labour, T&P ,supply of complete material sand bricks for laying of power cable including, lugs, connections suitable earthing as per CPWD specifications/IS. 2 numbers x size 4 Core x 10 sq.mm stranded copper conductor Remote control cable from Transmitter container to 82.5 KVA DG Set shed (1 number spare cable)	M	2x 80M
12.	Supplying ,laying/installation, testing & commissioning of 1.1KV grade , copper conductor, PVC insulated, PVC Sheathed armoured power supply cable in ground/trench/air including arranging labour,	Metre	80

5th October, 2010

- * Exact Length will be as per sites requirement.
- ** Exact sets will be as sites requirement
- # Rate shall be quoted per Item wise per number/per meter/ per job along with each quantity by the Tenderer)
- ## (Item wise details along with each quantity to be given by the tenderer)
- ^ Items are to be supplied by tenderer including lugs, connectors etc
- @ Volume of container/shelter

	<p>T&P ,supply of complete material sand bricks for laying of power cable including, lugs, connections suitable earthing as per CPWD specifications/IS. 2 numbers x size 4 Core x 6 sq.mm stranded copper conductor Remote control cable from Transmitter container to 62.5 KVA DG Set shed (1 number spare cable)</p>		
--	--------------------------------------------------------------------------------------------------------------------------------------------------------------------------------------------------------------------------------------------------------------------------------------------------------------------------------------------------------------------------------------------------	--	--

PART 4.12: (B) SCHEDULE OF REQUIREMENT/MATERIAL (UNPRICED) FOR DSETC EARTHING SYSTEM

Tenderers are requested to quote against the concerned Serial number of earthing Items for the respective Equipment in Part 4.0 of Specification.

PART 4.13 (A): SCHEDULE OF REQUIREMENT/MATERIAL (UNPRICED) FOR DSETC OF CONTAINER/SHELTER FOR RADIO TRANSMITTERS

S NO.	Description	Qty	Qty
i	<p>Design, supply of material/ arranging T&P, labour, erection, testing, commissioning, complete as per site requirement of Container/shelter for installation of Radio & TV Transmitters as per Specification including.</p> <p>(i) Heavy duty Base/Flooring (ii) Heat Insulation (iii) Flooring tiles (iv) Doors, windows, false ceiling (v) Finishing, painting (design and shade as per site requirement) Reference Suggestive drawing No.TM: like entrance sliding steel door from out side and sliding aluminum gate from inside, Double glass airtight windows of anodized aluminum with aluminum grill along with glass, handle lock, U-channel etc. Electrical work: Electrical fittings and other accessories etc. The quantities of items may vary as per actual site requirement. (i) Recessed type twin fluorescent 4'x40 W, mirror optic decorative fitting (ii) Container outside lights/Gate lights (iii)MCBs for Light & power installation (iv) SP&N, MCBs with industrial socket and metal box with steel frames (v)Light points, power points, light sockets etc. (vi)Automatic fire alarm system.</p>	Cubic M	@90 Cubic M One

5th October, 2010

- * Exact Length will be as per sites requirement.
- ** Exact sets will be as sites requirement
- # Rate shall be quoted per Item wise per number/per meter/ per job along with each quantity by the Tenderer)
- ## (Item wise details along with each quantity to be given by the tenderer)
- ^ Items are to be supplied by tenderer including lugs, connectors etc
- @ Volume of container/shelter

	<p>Electrical Switch gear etc. along with protection short circuit, over load & earth fault. Rates for above items will be quoted separately item wise by the tenderer.</p> <p>Electrical Wiring: Light Points wiring, power point wiring ,circuit wiring, sub main wiring and wiring for Ventilation equipment shall be carried out with copper wiring stranded conductor as per IS/ CPWD specification amended up-to-date 5 Amp light point 8 nos,2x40 watt 5 Amp plug point 4 nos x100 watt Cabin floodlight points/ gate light 5 nos x 100 watt 20 Amp MCB with Industrial Socket including Metal box frame complete for ventilating units.</p> <p>{Rate shall be quoted per cubic meter. Dimensions of container i.e. length(mm)X width (mm)X height (mm) shall be given by the tenderer as per regulatory & O&M requirement. @ for ranking purpose }</p>		
ii	Complete Earthing System, Lightning arrestor and accessories.	Set	1 Set complete

PART 4.13(B) SCHEDULE OF REQUIREMENT/MATERIAL (UNPRICED) FOR DSETC OF CONTAINER/SHELTER FOR POWER SUPPLY EQUIPMENT FOR RADIO TRANSMITTERS

S NO.	Description	Qty	Qty
i	<p>Design, Supply, Erection, testing & commissioning (DSETC) of Container/Shelter for power supply equipment for installation of Radio & TV Transmitters as per Specification including.</p> <p>(i) Heavy duty Base/ Flooring (ii) Heat Insulation (iii) Flooring tiles (iv) Doors, windows, false ceiling (v) Finishing, painting (design and shade as per site requirement) Reference Suggestive drawing No.TM: like entrance sliding steel door from out side and sliding aluminum gate from inside, Double glass airtight windows of anodized aluminum with aluminum grill along with glass, handle lock, U-channel etc.</p> <p>Electrical work: Electrical fittings and other accessories etc. The quantities of items may vary as per actual site requirement. (i) Recessed type twin fluorescent 4'x40 W, mirror optic decorative</p>	Cubic M	@70 Cubic M One

5th October, 2010

- * Exact Length will be as per sites requirement.
- ** Exact sets will be as sites requirement
- # Rate shall be quoted per Item wise per number/per meter/ per job along with each quantity by the Tenderer)
- ## (Item wise details along with each quantity to be given by the tenderer)
- ^ Items are to be supplied by tenderer including lugs, connectors etc
- @ Volume of container/shelter

	<p>fitting (ii) Container outside lights/Gate lights (iii) MCBs for Light & power installation (iv) SP&N, MCBs with industrial socket and metal box with steel frames (v) Light points, power points, light sockets etc. (vi) Automatic fire alarm system. Electrical Switch gear etc. along with protection short circuit, over load & earth fault. Rates for above items will be quoted separately item wise by the tenderer.</p> <p>Electrical Wiring: Light Points wiring, power point wiring, circuit wiring, sub main wiring and wiring for Ventilation equipment shall be carried out with copper wiring stranded conductor as per IS/ CPWD specification amended up-to-date 5 Amp light point 6 nos, 2x40 watt 5 Amp plug point 4 nos x 100 watt Cabin floodlight points/ gate light 5 nos x 100 watt 20 Amp MCB with Industrial Socket including Metal box frame complete for ventilating units.</p> <p>{Rate shall be quoted per cubic meter. Dimensions of container i.e. length(mm)X width (mm)X height (mm) shall be given by the tenderer as per regulatory & O&M requirement. @ for ranking purpose}</p>		
ii	Complete Earthing System, Lightning arrestor and accessories.	Set	1 Set complete

PART 4.14: SCHEDULE OF REQUIREMENT/MATERIAL (UNPRICED) FOR SETC OF FOR TECHNICAL MANUALS, FURNISHING & MISCELLANEOUS ITEM/EQUIPMENT FOR TRANSMITTERS SETUPS (FOR EACH SITE)

(A) TECHNICAL MANUALS

S NO.	Description	Unit	Qty
1.A.	Technical manuals for Installation, testing, commissioning, Operation & Maintenance, including Theory of operation and fault diagnosis printed and duly bound for 10kW VHF FM (1+1) transmitter, Automatic change over unit for 10 kW FM Transmitters in (1+1) mode hot stand by with automatic control with transmitters control units complete,		

5th October, 2010

- * Exact Length will be as per sites requirement.
- ** Exact sets will be as sites requirement
- # Rate shall be quoted per Item wise per number/per meter/ per job along with each quantity by the Tenderer)
- ## (Item wise details along with each quantity to be given by the tenderer)
- ^ Items are to be supplied by tenderer including lugs, connectors etc
- @ Volume of container/shelter

Specification no: SETC-10 KW TX (1+1) Naushera (Mangla Devi Fort) /J&K/ October/ 2010/D (TD/FM)

	<p>15 kW Dummy Load and thru line power meter etc., RF Coaxial air dielectric feeder cable system, dehydrator system, RF coaxial Copper Rigid Line with all hardware accessories, RF Coaxial copper rigid lines, Motorized RF co-axial Changeover switch, Stereo & Digital Programme Input-Cum-Monitoring Rack, Stereo FM Digital Audio Broadcast processor equipment, FM Mono and Stereo Mod Monitor to be used in – tandem with RF amplifier, 16 panel VHF FM Antenna, RF Coaxial Cable, Antenna switch panel/frame, RF Coaxial Rigid Lines & Accessories - along with one soft copy on CD & Inspection Report of the inspection carried out at Tenderer's OEM Works</p> <p>Dynamic Microphone and Professional CD player/DVD Player, Complete</p> <p>Measuring equipment as per specification in Part 2.5, Digital Radio Receiver AM, FM, SW, C Band terminal, DTH, Power supply equipment 82.5 KVA(1+1) DG Set, 40 KVA (1+1) UPS on line, 40 KVA AVR, 40 KVA Isolation transformer, Ventilation equipment & RN Terminal equipment with decing kit & DTH KU band etc as per distribution given below along with one soft copy on CD.</p>		
1.A.1	For DE (Proj.) P&D Unit, DG: AIR {Within Two Months of Supply order} (irrespective of number of transmitters to be ordered)	Set	1 set complete
1.A.2	For Consignee Technical manuals are to be supplied) {To be supplied along with the equipment}. (irrespective of number of transmitters to be ordered)	Set	2 sets complete
1.A.3	For following offices: Technical manuals are to be supplied) {To be supplied along with the equipment}. (irrespective of number of transmitters to be ordered)		
i	DE((Proj.),P&D Unit,DG: AIR (1 set)		
ii	Zonal Office (Project Wing) (1 set)		
iii	Zonal Office (Maintenance Wing) (1 set)		
iv	DE(Transmitter Maintenance), DG: AIR (1 set)		
v	ST(I), Delhi (1 set)		
vi	R & D, Delhi (1 set)		
	Total (6 sets)	Set	6 sets

5th October, 2010

* Exact Length will be as per sites requirement.

** Exact sets will be as sites requirement

Rate shall be quoted per Item wise per number/per meter/ per job along with each quantity by the Tenderer)

(Item wise details along with each quantity to be given by the tenderer)

^ Items are to be supplied by tenderer including lugs, connectors etc

@ Volume of container/shelter

PART 4.1(A) : (OPTIONAL) SCHEDULE OF REQUIREMENTS / MATERIALS UNPRICED)
(OPTIONAL)

{The tenderer must quote all items}

FOR ONE SET OF TRANSMITTER & ASSOCIATED EQUIPMENT)

S NO.	Description	Unit	Qty
1.	Training Charges at Delhi for AIR engineers for complete system for 3 working days.	number	1 number
2.	A set of RF, DC power supply and control cables with appropriate connectors , extender cables and extender cards etc.	Set	1 Set Complete
3.	List of recommended spares and any other accessories. Items wise details of the offered material (including part number, if any) are to be given by the tenderer. In case of kits, full item wise details of kits are to be provided. Tenderer should quote the rate / cost of individual items/unit/spares in the tender offer while submitting the offer for spares. Recommended Spares for One set of transmitter : These should include: i. IPA, PA MOSFET / Sub Modules ii. PCB's / Interface Cards/modules iii. Kit for spares comprising of Low power semi conductor devices/ MOV/Tunnel Diodes, IC's/L.S.I.,PCB's/Interface Cards/ modules, Switches/ Opto couplers/ Transducers & Meters/ Displays etc. iv. Spare Modules IPA and PA. v. Sub assemblies/Changeover Units vi. Spare power supply unit vii. Complete control unit/Microprocessor Controller viii. One set of filter ix. Blower with motor x. Other miscellaneous items including power combiner, its sub-systems, harmonic filter, absorbers, etc.	Set	1 Set complete
4.	Recommended Spares for 10 kW Dummy Load and thru line power meter etc.	Set	1 Set complete
5.	Spare element for thru line power meter, 15,000 W	number	1 number
6.	Spare element for thru line power meter, 1,500 W	number	1 number
7.	Recommended Spares for RF Coaxial rigid lines	Set	1 Set complete
8.	Recommended Spares for automatic changeover unit (1+1)	Set	1 Set complete
9.	Recommended Spares for Motorized RF Coaxial change over Switch	Set	1 Set complete
10.	Recommended Spares for FM Mono and Stereo Mod Monitor to be used in – tandem with RF amplifier as per specification.	Set	1 Set complete
11.	Remote Control & Telemetry Equipment as per Section -II and		

5th October, 2010

* Exact Length will be as per sites requirement.

** Exact sets will be as sites requirement

Rate shall be quoted per Item wise per number/per meter/ per job along with each quantity by the Tenderer)

(Item wise details along with each quantity to be given by the tenderer)

^ Items are to be supplied by tenderer including lugs, connectors etc

Specification no: SETC-10 KW TX (1+1) Naushera (Mangla Devi Fort) /J&K/ October/ 2010/D (TD/FM)

	Section-III. Remote Control & Telemetry Equipment via distant/centralized location via ISDN/Digital lines/TCP-IP / PSTN network/VSAT		
11.1	General Purpose PC complete as required	Set	2 Sets
11.2	Remote Control System complete as required	Set	1 Set
11.3	Wiring Interface Unit	Set	1 Set
11.4	Dial line Suppressor	Set	1Set
11.5	External Modems	Set	2 Sets
11.6	Complete software, hardware items, accessories, single/ multi core cables, RF cable connectors, Humidity/temperature transducer, 2/3 Core Shielded Teflon cable, Extension cables etc. (Items wise details of offered and included material ,items & part are to be given by the tenderer)	Set	1 Set
11.7	Any other accessories offered for the completeness of the system (Items wise details of offered and included material , items & part are to be given by the tenderer)	Lot	1 lot

4.1 (B) (OPTIONAL) SCHEDULE OF MATERIAL/REQUIREMENT FOR SUPPLY INCLUDING ESSENTIAL AND RECOMMENDED SPARES) (UNPRICED) (FOR ONE Set of Stereo FM Digital Audio Broadcast Processor)

SNo.	Description	Unit	Qty
1.	Modules	Set	1 Set
2.	PCBs	Set	1 Set
3.	Any other item offered by the firm for the completeness of equipment	Lot	1 lot
4.	Remote Computer Interface	Set	1 Set
5.	Telemetry Interface etc.	Set	1 Set

PART – 4.2 (A) (OPTIONAL) SPARES ITEMS: [FOR ONE SET OF 16 PANEL VHF FM ANTENNAS]

SECTION 5.2 Schedules of Supply (Optional)

SNo.	DESCRIPTION	Unit	Qty.
1.0	16 Panel VHF FM (Band II) Complete Antenna System : Spares (Optional): List of recommended spares and any other accessories. (Items wise details of offered material including part numbers, if any are to be given by the tenderer). In case of kits, full item wise details of kits are to be provided. The tenderer shall quote for one set of manufacturers recommended list of spares for Complete antenna system based on the actual failure pattern. These may include following:		

5th October, 2010

- * Exact Length will be as per sites requirement.
- ** Exact sets will be as sites requirement
- # Rate shall be quoted per Item wise per number/per meter/ per job along with each quantity by the Tenderer)
- ## (Item wise details along with each quantity to be given by the tenderer)
- ^ Items are to be supplied by tenderer including lugs, connectors etc

Specification no: SETC-10 KW TX (1+1) Naushera (Mangla Devi Fort) /J&K/ October/ 2010/D (TD/FM)

a	“O” ring	set	1set
b	Silicon grease	lot	1 lot
c	Connectors assorted sizes	set	1set
d	RF distributors air dielectric coaxial cables	set	1set
e	Dipole	number	2 numbers
f	Other miscellaneous items.	Lot	1lot
2.0	Any other item / hardware etc. offered for the completeness of the above antenna system - 1 lot (Item wise details of the offered item / hardware material etc. shall be given by the tenderer)	lot	1lot

4.3 (A) SCHEDULE OF MATERIAL/REQUIREMENT FOR SUPPLY (OPTIONAL INCLUDING ESSENTIAL AND RECOMMENDED SPARES) (UNPRICED) (FOR ONE Set of RN Terminal Equipment with Deicing kit)

SNo.	Description	Unit	Qty
1.	Modules	Set	1 Set
2.	PCBs	Set	1 Set
3.	Spare low loss cable with connectors.- 50 M	number	1No
4.	Any other item offered by the firm for the completeness of equipment	Lot	1lot

PART: 4.4(A)

SECTION-4 SCHEDULE OF MATERIAL/REQUIREMENT FOR SUPPLY (OPTIONAL INCLUDING ESSENTIAL AND RECOMMENDED SPARES) (Unpriced) (For one set of Stereo & Digital Programme Input-Cum-Monitoring Rack)

SNo.	Description	Unit	Qty
1.0	Cooling fans complete	No	1 No
2.0	DC SUPPLY : In case any of the Rack equipment is to operate on a separate DC Supply , one such unit is to be offered as spare and price are to be quoted separately as optional	No	1 No
3.0	Any other item as per recommendation of manufacture.	Lot	1 Lot

5th October, 2010

- * Exact Length will be as per sites requirement.
- ** Exact sets will be as sites requirement
- # Rate shall be quoted per Item wise per number/per meter/ per job along with each quantity by the Tenderer)
- ## (Item wise details along with each quantity to be given by the tenderer)
- ^ Items are to be supplied by tenderer including lugs, connectors etc

PART 4.6 SCHEDULE OF REQUIREMENT/MATERIAL (UNPRICED) FOR SETC FOR STAND ALONE SILENT TYPE DIESEL GENERATOR SETS 82.5 KVA (1+1) (OPTIONAL)

4.6.1	Consumable spares required for operation of the D.G. Set for 2 years. (List of spares to be enclosed)##	Set	1 Set# (1+1)
4.6.2	Special tools required for field maintenance and repair of Diesel Generator excluding Standard Tools which are part of Generator (List of Tools to be enclosed)##	Set	1 Set# (1+1)
4.6.3	Charges for operation for 18 hrs. per day & routine maintenance including all consumable except fuel & lube oil for one year, during warrantee period. (Optional)##	Job	1 job# (1+1)
4.6.4	Charges for comprehensive AMC for 2 nd year, 3 rd year, 4 th year & 5 th year. (Details of items covered under AMC for repairs/ replacement, routine inspection/ checking/ adjustments/ measurements and periodic maintenance schedule intended to be adopted by the tenderer shall be annexed to the technical bid.)##)(Optional)	Job	1 job# (1+1)
4.6.5	SETC of heating system for starting as per specification with complete accessories ##	Set	1 Set# (1+1)
	Spares :		
4.6.6	Spares required for operation of the D. G. Set for 2 years.(detailed list item wise with part number to be enclosed) (Optional)##	sets	1 sets (1+1)#

PART 4.7 SCHEDULE OF REQUIREMENT/MATERIAL (UNPRICED) FOR SETC FOR STAND ALONE SILENT TYPE DIESEL GENERATOR SETS 62.5 KVA (1+1) (OPTIONAL)

4.7.1	Consumable spares required for operation of the D.G. Set for 2 years. (List of spares to be enclosed)##	Set	1 Set# (1+1)
4.7.2	Special tools required for field maintenance and repair of Diesel Generator excluding Standard Tools which are part of Generator (List of Tools to be enclosed)##	Set	1 Set# (1+1)
4.7.3	Charges for operation for 18 hrs. per day & routine maintenance including all consumable except fuel & lube oil for one year, during warrantee period. (Optional)##	Job	1 job# (1+1)
4.7.4	Charges for comprehensive AMC for 2 nd year, 3 rd year, 4 th year & 5 th year. (Details of items covered under AMC for repairs/ replacement, routine inspection/ checking/ adjustments/ measurements and periodic maintenance schedule intended to be adopted by the tenderer shall be annexed to the technical bid.)##)(Optional)	Job	1 job# (1+1)

5th October, 2010

- * Exact Length will be as per sites requirement.
- ** Exact sets will be as sites requirement
- # Rate shall be quoted per Item wise per number/per meter/ per job along with each quantity by the Tenderer)
- ## (Item wise details along with each quantity to be given by the tenderer)
- ^ Items are to be supplied by tenderer including lugs, connectors etc

Specification no: SETC-10 KW TX (1+1) Naushera (Mangla Devi Fort) /J&K/ October/ 2010/D (TD/FM)

4.7.5	SETC of heating system for starting as per specification with complete accessories ##	Set	1 job# (1+1)
	Spares :		
4.7.6	Spares required for operation of the D. G. Set for 2 years.(detailed list item wise with part number to be enclosed) (Optional)##	sets	1 sets (1+1)#

PART 4.8: SCHEDULE OF REQUIREMENT/MATERIAL (UNPRICED) FOR SETC OF ON LINE UNINTERRUPTED POWER SUPPLY SYSTEM 40 KVA (UPS)

(Bill of material must be in the format given below for technical and commercial quotes).

Spares: (Optional)

	Spares:	Unit	Qty
4.8.6	Spares required for operation of the On Line UPS system for 2 years.(detailed list item wise with part number to be enclosed##	Set	1 Set complete #

PART 4.9: SCHEDULE OF REQUIREMENT/MATERIAL (UNPRICED) FOR SETC OF 80 KVA AVR

Spares: (Optional)

	Spares:	Unit	Qty
4.9.6	Spares required for operation of AVR for 2 years.(detailed list item wise with part number to be enclosed##	Set	1 Set complete #

PART 4.10: SCHEDULE OF REQUIREMENT/MATERIAL (UNPRICED) FOR SETC OF 80 KVA ISOLATION TRANSFORMERS

Spares: (Optional)

	Spares:	Unit	Qty
4.10.6	Spares required for operation of the Isolation Transformer for 2 years.(detailed list item wise with part number to be enclosed##	Set	1 Set complete #

5th October, 2010

- * Exact Length will be as per sites requirement.
- ** Exact sets will be as sites requirement
- # Rate shall be quoted per Item wise per number/per meter/ per job along with each quantity by the Tenderer)
- ## (Item wise details along with each quantity to be given by the tenderer)
- ^ Items are to be supplied by tenderer including lugs, connectors etc

PART 4.11: SCHEDULE OF REQUIREMENT/MATERIAL (UNPRICED) FOR DSETC OF VENTILATION EQUIPMENT FOR TRANSMITTERS. (FOR EACH SITE)

Spares: (Optional)

	Spares:	Unit	Qty
4.11.2	Spares required for operation of the 1.5 T, Reversible Type air conditioners for 2 years. (detailed list item wise with part number to be enclosed)##	Set	1 Set complete #

5th October, 2010

* Exact Length will be as per sites requirement.

** Exact sets will be as sites requirement

Rate shall be quoted per Item wise per number/per meter/ per job along with each quantity by the Tenderer)

(Item wise details along with each quantity to be given by the tenderer)

^ Items are to be supplied by tenderer including lugs, connectors etc