

**PRASAR BHARATI
(BROADCASTING CORPORATION OF INDIA)
ALL INDIA RADIO
(TELECOM CELL)**

SPECIFICATIONS COVER SHEET

TITLE	:	Specification for Digital-cum-Analog C-Band RN Terminal
SPECIFICATION NO.	:	TC/SPEC/08/2003/RNT
DATE OF LAST UPDATION	:	NOV, 2007
NO.OF PAGES	:	24
SCHEME	:	Provision of C Band RN Terminals at 44 AIR stations under 11 th Plan .

**PRASAR BHARATI
(BROADCASTING CORPORATION OF INDIA)
ALL INDIA RADIO
(TELECOM DIVISION)**

.....

No.TC/SPEC/08/2003 (C- Band RNT)

SPECIFICATIONS FOR C- BAND RN TERMINAL

1. INTRODUCTION :

The AIR broadcasting stations spread throughout the country, are required to relay certain programmes which are originated from Delhi and from other Regional Stations in State Capitals. In order to link Delhi and Capital stations etc. with other stations, for the purpose of these relays, AIR uses Satellite Radio networking through INSAT series of Satellites.

The RN Receive Terminals located at AIR stations act as Ground Terminals, to receive C-Band transmissions through satellite. These programmes thus downlinked, are fed to the transmitters for broadcast purposes.

Present specifications are for providing complete C-band RNT at 24 AIR stations and partial C-band RNT at 20 AIR Stations under 11th plan.

Sections below give details of the scope and specification of these Receive terminals. The Networking through satellite is in SCPC mode. Details of the networking & INSAT system parameters are also furnished to enable tenderers to design & offer appropriate system compatible with the existing setup.

2. CONFIGURATION OF THE COMPLETE C BAND SYSTEM :

List of Stations where complete/partial C-Band RN system has to be provided along with configuration of the required system at each of the stations is at Annexure-A. Configuration at Stations where complete C-Band System has to be provided is shown in a diagram at **Annexure - 'D'**.

Schedule of Items to be supplied against this Configuration is as per follows:

A. MANDATORY ITEMS:

SI No	Item No	Quantity/Station		
		For Stations in Annexure A-1	For stations in Annexure A-2	For Stations in Annexure A-3
2.1	6 Meter Parabolic Dish Antenna along with Earthing System, Lightning arrestor, feed and accessories	1 Set	1 Set along with De-icing System	-----
2.2	a) LNBC C-Band --- 2Nos	1 Set	1Set	1 Set
	b) 50M length Low loss cable with connectors--- 2Nos			
	c) L band 1:4 Power divider --- 1No			
2.3	L-Band Digital Receiver	2Nos 4Nos(for National Channel)	-----	4Nos
2.4	L-Band Analog Receiver	1Nos 2Nos(for National Channel)	-----	2Nos
2.5	Full size wired rack(42U) with jack strip and tag block (Refer Annexure E & F)	1 No.	-----	-----
2.6	Stereo Monitoring Amplifier(10 W) with a set of speakers	1 Set	-----	-----
2.7	Other accessories like connectors and integration material	1 set	1 Set	1 Set
2.8	PC	1 No.	1 No.	1 Set
2.9	Installation and Commissioning of the System at the Stations	1 Job	1 Job	-----
2.10	Inspection as per approved ATP	1 Job	1 Job	1 Job
2.11	Two days training at site	1 Job	-----	-----

B. OPTIONAL ITEMS

2.12	One week centralized training	1 Job		
2.13	Low loss cable Per meter length (to be quoted separately)	---		

- Note: 1. All the items have to be quoted separately.
2. Quote made for Optional items will not be considered for ranking.**

3. SCOPE

3.1 The scope of this tender **in general** includes supply of the equipment as per specifications, technical requirements and quantities as detailed in the tender after acceptance testing as per approved Acceptance Test Procedure (ATP). The installation and commissioning of these C-Band receive terminals at site **wherever specified** shall be carried out by the supplier.

For Stations listed in Annexure-A-1 , scope of the work includes supply of complete C-Band Receive system, its installation, Testing and commissioning.

For Stations listed in Annexure-A-2 , scope of the work includes supply of partial C- Band Receive system items projected in Annexure A-2, its installation, testing and integration with the existing system at the Station.

For Stations labeled in Annexure-A-3 , scope of the work includes supply of partial C- Band Receive system items projected in Annexure A-3 and its testing.

3.2 After acceptance of the tender, the tenderer shall also provide detailed plans of supply of material and testing as per ATP.

3.3 The indenter shall provide the necessary space for the installation of the equipment, layout plan of the cable and location of the parabolic dish antenna (wherever applicable), etc.

3.4 The complete installation of RN Terminal at Stations in Annexure A-1, including ground leveling, required foundation for the PDA and construction of platform shall be carried out by the tenderer. At few locations antenna may be required to be installed at the roof top. **Charges for installation of PDA on roof top should be quoted optional.**

3.5 Installation and Integration of PDA at Stations in Annexure A-2, including ground leveling, required foundation for the PDA and construction of platform shall be carried out by the tenderer.

3.6 During the installation of these equipment, supplier shall be responsible for safety and security of his material and personnel. At the same time the supplier will also ensure that no damage to AIR material and personnel is caused. There shall be no disruption of running services at the Station during installation and commissioning.

3.7 The tenderer shall ensure that the equipment offered fully incorporate the standard features for safety and protection including shielding from EMI.

3.8 The suppliers will have to supply the equipment, arrange for its testing as per mutually agreed Acceptance Test Procedure and provide facilities and equipment to carry out the testing. The installation and commissioning of these C- Band receive terminals at site will be carried out by the supplier. A draft copy of the Acceptance Test Procedure is attached in **Annexure C** .

3.9 Pre dispatch inspection will be carried out at Supplier/Integrator's works by the Engineers (s) of All India Radio. The supplier shall put up all the equipment for test on the test bench at supplier/integrator premises before the AIR representative and shall provide, without any extra charges, electric energy, consumable materials, tools, testing instruments, labour and assistance of every kind for carrying out acceptance tests. All the individual factory test reports of the complete lot of the equipment shall be made available to the inspecting authority before inspection.

Complete specifications and details will be checked and all parameters values will be measured. Typical details are enclosed in draft ATP, The inspection will be carried out on those lines. Prior intimation for carrying out inspection at Works is to be given by the supplier to the indenter at least six weeks in advance. **Inspection charges if any are to be quoted separately.**

- 3.10 Supplier shall arrange two days' training at each of the location to AIR personnel on operation and maintenance of the equipment.
- 3.12 One week training for 12 engineers (two engineers from each zone , one from STI(T) and one from Directorate) in servicing of the equipment will be required to be arranged at a centralized location in the country.
- 3.13 Delivery period for SITC for all the items shall be six months after placing the Advance A/T.

4. LOCATION FOR SUPPLY OF RN TERMINAL EQUIPMENT:

These RN Receive terminals will be supplied at the locations listed in **Annexure-'A 1 to A-3'**.

5. SYSTEM PARAMETERS & COMPATIBILITY :

The system parameters of AIR's Radio Net-working system and INSAT system details are enclosed as **Annexure - 'B'**. While quoting for the RN Terminals, the tenderer may refer to these details to ensure conformity to the existing uplink system. Then tenderer should also check up system design and link budget to ensure satisfactory operation and trouble free service of the equipment set up when installed.

6. GUARANTEE & RELIABILITY :

In addition to standard guarantee and warranty clauses mentioned in the tender, the tenderer/supplier will ensure the following :

- The equipment offered should be capable of continuous round the clock operation.
- It shall be field proven, of state of art technology and based on industry standard.

7. GENERAL CLAUSES :

- (i) The supplier shall intimate the source of supply and technical parameters for major and critical components/spares so that no difficulty is encountered later on in procuring the spares for maintenance and repair of these equipment.
- (ii) If at any stage during next ten years the manufacturer stops production of these equipment, he shall intimate AIR in advance to enable AIR to stock the critical items of spares for the life of the equipment.
- (iii) Warranty and guarantee clause will be as per the terms and conditions specified in the commercial section of the tender in this respect.
- (iv) The tenderer shall quote all the optional items.
- (v) The supplier shall provide the list of clients where they have supplied the same kind of the system.
- (vi) The supplier may be asked to demonstrate the working of the complete quoted system or some of the equipment, if required.
- (vii) Tenderer shall submit one Digital Receiver & one analoge receiver offered by them within 15 days of opening of the tender to facilitate Evaluation. These samples would be returned after testing. Tenderers who do not submit sample for digital and Analog Receiver shall be rejected.**

8. TECHNICAL SPECIFICATION FOR DIGITAL CUM ANALOG RECEIVE TERMINAL

The Digital cum Analog Receive terminal should confirm to the following technical specifications.

8.1 Specification for 6M Diameter C-Band PDA:

Electrical Specification:

i)	Diameter	It should be greater than 6 Meter but less than 6.3 Meter and should meet the gain requirements mentioned below.
ii)	Frequency Range	3.7 –4.2 GHz
iii)	Receive gain at 4 GHz	≥46 dB
iv)	Receive G/T	Better than 24.5 dB/°K
v)	Pointing Accuracy	Better than ± 0.25°
vi)	Side Lobe Level/Gain pattern	As per ITU-R S-580-V or its latest amendment
vi)	Tracking mode	Manual (motorized may be quoted as optional). The Antenna should have calibrated marking for Elevation & Azimuth angle indication.

Mechanical Specification:

Sl No	Parameter	Specification
1	Reflector Structure:	The reflector should be made of perforated aluminum sheet mounted as panels/segments over reflector supporting structure. The reflector supporting structure should be made from aluminum or steel tubes/angles and mounted over trusses emanating from the central hub.
	i) Reflector Material:	Perforated Aluminum sheet with thickness of at least 2.0mm
	ii) Coated with:	Non metallic anti corrosive paint to avoid concentration of heat at focal point (mention the paint used)
	iii) Reflector supporting structure:	Should be made from Aluminum /Steel material. It should be coated with anti corrosive paint
2	Antenna Stand:	
	Mount:	Kingpost
	Material:	Heavy duty, made with hot dip Galvanized steel and coated with anti corrosive paint.
4	Steerability:	
	Elevation:	15° to 85°
	Azimuthal:	≥ ± 55°(continuous, without change of mount position)
5	Wind Load:	
	Operational:	80 KM/Hr
	Survival:	150 KM/Hr
6	I) Environmental condition for the stations listed in of Annexure A-1	
	Temperature:	-5° to +50°C
	Relative Humidity:	95% non condensing at 40°C

Rain:	Up to 10 cm/hr
II) Environmental condition for the stations listed in Annexure A-2	
Temperature	-40° to +40°C
Relative Humidity:	95% non condensing at 40°C
De icing system	Suitable De icing system should be provided with antenna so that system is operational during and after snowfall. Foundation of antenna should also be capable to withstand these climatical conditions.

NOTE: The tenderer (as per drawings and recommendations by the original manufacturer of the antenna) will provide Foundation of the antenna. One no of proper earth pit will have to be provided for earthing the lightning arrester of the antenna.

8.2 a) DETAILS OF THE FEED

- | | | |
|-------|-----------------------------------|--|
| i) | Type of Mounting | Prime Focus. The provision for adjustment of the feed from the ground itself should be made. It should have calibrated polarization angle indication and adjustable smoothly for optimization. |
| ii) | Ports | Two (Orthogonal) |
| iii) | Polarisation | Linear (adjustable, $\pm 90^\circ$) |
| iv) | Freq. Range | 3.7 - 4.2 GHz |
| v) | Gain slope in Freq. band | 10 dB |
| vi) | Return loss at Centre freq. | ≥ 17 dB |
| vii) | Connector | Wave-guide WG229G |
| viii) | Cross-Polarization discrimination | ≥ 33 dB (on axis)
30 dB (1 dB BW) |

Note : Feed of C-Band antenna would be two port (orthogonal). One LNBC would be mounted over each of the port. At a time only one LNBC output would be connected to the input of 1:4 power divider. The other LNBC mounted over orthogonal port will serve as cold stand by. Arrangement should be provided so that by rotating the feed by 90° , the standby LNBC could be brought into the circuit.

8.2b) Deicing System: (For the stations listed in Annexure A-2)

Offered Deicing system should have following features:

1. Deicing system should be of heating element type made of Teflon.
2. Heating element of appropriate length has to be fixed on ground facing side of reflector panel.
3. At least half of total number of reflector panels has to be fitted with heating element.
4. Deicing system should maintain reflector surface temperature at above 5°C .
5. System should be shock proof and proper insulation has to be provided to eliminate fault current. Appropriate rated RCCB's has to be provided for tripping whenever heating element shorts to Antenna reflector panels.

6. Deicing system has to be provided with thermostat for facilitating auto regulation of the Deicing system.
7. Deicing system has to be provided with circuit breaker for switching ON and OFF of the system manually.
8. Pilot lamp indicators have to be provided for indicating functioning of the De-icing system.
9. Number of heating elements used in the offered deicing and total power requirement of the offered system shall be indicated clearly.

8.3 Cable

Only good quality professional grade cable(RG 35) shall be quoted with following specifications

- | | | |
|-----|--|----------------------------------|
| i) | Cable Loss(RG 35 with F connectors at both ends) | ≤ 3 dB/100 feet at 1500 MHz |
| ii) | Impedance | 75 Ω |

8.4 L Band 1:4 Passive Power divider

Only good quality professional grade 1:4 Passive power divider shall be quoted with following specifications. Only one out of 4 ports of power divider should be capable to pass dc voltage (+15 to +24 volt) from Receiver to LNBC.

- | | | |
|-----|-----------------------|---------------|
| (a) | Type of splitter | passive type |
| (b) | No.of outputs | Four |
| (c) | Typical division loss | ≤ 6.5 dB |
| (d) | Input impedance | 75 ohm |
| (e) | Output impedance | 75 ohm |

8.5 C- BAND L.N.B.C.

- | | | |
|-------|----------------------------|-------------------------------------|
| i) | Input Freq. Range | 3.7 - 4.2 GHz |
| ii) | Output freq. | 950 - 1450 MHz |
| iii) | Input Impedance | 50 Ω |
| iv) | Output impedance | 75 Ω |
| v) | Input connector | CPR 229 G Flange |
| vi) | Typical Noise temperature | $\leq 45^\circ\text{K}$ |
| vii) | Conversion gain | ≥ 55 dB |
| viii) | Gain flatness | $\leq \pm 2$ dB, p-p over full band |
| ix) | Typical Input /Output VSWR | $\geq 2.2 :1$ |
| x) | Input/Output interface | As per antenna/receiver |
| xi) | Dynamic range | ≥ 80 dB |

xii)	Minimum Image rejection	45 dB or better.
xiii)	Spurious / Harmonics	≤ -50 dBc.
xiv)	Power supply	+15 to +24 V through output connector.
xv)	Phase noise	
	@ 1 KHz	≤ -65 dBc/Hz
	@ 100 KHz	≤ -80 dBc/Hz
xvi)	L.O. Stability	PLL, better than ±2 PPM over the temp.range from 0° to 50°C and over 24 Hrs.

8.6 DIGITAL RECEIVER (DEMODULATOR + DECODER)

The Digital receiver should conform to the standard and specification of the existing digital radio networking system in AIR (Refer Annexure C1). The existing digital modulators/ encoders are Radyne TIERNAN make . So receiver should be compatible with the same. It should be possible to control/ set receivers through front panel as well as through PC.

i)	Input	
	a) Freq. Range	950 - 1450 MHz
	b) Freq. Step size	1 kHz Local (remote control optional)
	c) Impedance	75 Ω
	d) Level	≤ -25 to -70 dBm
ii)	Demodulation	QPSK and BPSK (user selectable)
iii)	Carrier lock range	≥ ±500 KHz
iv)	FEC decoding	Viterbi rate 1/2,(3/4optional) Sequential Rate ½ (Selectable Rate preferred)
v)	Audio coding	ISO/MPEG-I/Layer-2
vi)	Data rates (Selectable)	64, 128, 192 & 256,kbps (QPSK) 64, 128, 192 & 256 kbps (BPSK)
vii)	Modes	Mono, Dual mono & Joint stereo
viii)	Audio output	
	a) Impedance	≤ 600 Ω
	b) Level (Maximum)	+ 8 dBu (adjustable)
	c) T.H.D.(at1KHz, @ 256kbps)	≤ 0.2% (at +8 dbu output)
	d) Audio signal bandwidth	20 Hz to 20 KHz
	e) Frequency response	1.0 dB peak to.peak (20 Hz to 20 KHz, @ 0dBu)
	f) Signal to Noise ratio	≥ 70 dB (referred to +8 dbu output)
	g) Dynamic range	≥ 80 dB
	h) Cross-talk ratio	≥ 75 dB at 8dBu output.
	i) Audio output channels	Two mono/one stereo
	j) Digital Audio output	AES / EBU STANDARD (Professional)

ix)	Threshold Eb/No	≤ 5.5 dB(QPSK) , 5 dB(BPSK)
x)	B.E.R. Immunity (@128 kbps, QPSK, Seq. rate 1/2 and 5.5 Eb/No)	1×10^{-5} for no subjective loss in quality
xi)	Audio Sampling Rate	48 KHz (44.1kHz and 32kHz optional)
xii)	Stereo Phase deviation	$\leq 1.5^\circ$ for 20 Hz to 10 KHz; $\leq 3^\circ$ for 10 KHz to 20 KHz.
xiii)	Auxillary data channel	
	a) Data rate	≥ 4.8 Kbps
	b) Interface	RS – 232
(x)	Output voltage to LNBC	+15volt to+24 volt, 500 mA(max current)

8.7 ANALOG RECEIVER

The existing Analog Transmission/Modulator system being used in the AIR's Radio Networking is of Sat. System Corp. make . So the receiver should be compatible with the same.

i)	Frequency	950 - 1450 MHz
ii)	I.F. Frequency Tune	52 to 88 MHz in 10 KHz step.
iii)	Transponder Tune	Selectable 1 to 24
iv)	No. of channels	Two independent channels
v)	Audio Frequency Response	± 1 dB, reference 1kHz at -20 dBm (50 Hz to 15 kHz)
vi)	De-emphasis	75 μ Sec
vii)	Audio output @ ± 75 kHz deviation	+9 dBm max. front panel adjustable.
viii)	Stability factor (Receiver)	PLL System, ± 15 KHz.
ix)	Tuning steps	10 KHz, all frequencies
x)	S/N ratio	≥ 65 dB
xi)	Input Impedance	75 Ω
xii)	Audio output Impedance	600 Ω balanced
xiii)	Audio expanding	1 : 2
xiv)	Demodulation	FM
xv)	C/No Threshold	64 dB-Hz.
xvi)	THD	Less than 1% at +9dBm
xvii)	Output voltage to LNBC	+15volt to+24 volt, 500mA(max current)

8.8 10 Watt Monitoring Amplifier

FEATURES

The amplifier shall essentially have the following features:

- a. Protection against current overloads : The amplifier should mute in case of overload and revert to normal functioning once overload ceases to exist.
- b. Protection against thermal overload : Temperature of power pack and heat sinks of both channels should be monitored continuously and the amplifier should get muted with a visual indication whenever temperature exceeds permissible limits. In case of excessive temperature of heat sinks, the amplifier should be protected, by fuse blow up or by any other suitable measures.
- c. Monitoring amplifier output should be continuously monitored for DC components or very low frequency components which might endanger speaker if present for longer durations. Amplifier output should get blocked in such an eventuality.
- d. The amplifier should have protection against open circuit, full short circuit, ultrasonic frequencies and RF.
- e. Necessary function switches such as volume/gain control, low and high frequency filters should be available on front panel. These controls shall be rugged and reliable.

INPUTS & OUTPUTS

1. No. of inputs (stereo) : Analog and AES/EBU
(XLR female connectors)
2. Input level
 - a) Nominal level : 0 dBu
 - b) Range : -10 dBu to +10 dBu for rated output
3. Input impedance : ≥ 10 k ohms
4. CMRR (20 Hz – 20 kHz) : ≥ 60 dB
5. Output impedance : 8 ohms.
6. Power Output : 10 W rms continuous per channel at 8Ω .
7. Frequency Response
With reference to 1 kHz over : Better than ± 1 dB
The entire range of 20 Hz to 20 kHz
8. Total Harmonic Distortion : $\leq 0.5\%$ at rated output
at 1 kHz
9. Signal-to-noise-ratio
With input shorted and at : Equal to or better than 85 dB
rated output (unweighted
rms) at 0dBu input
(22 Hz- 22 kHz)
10. Damping factor : ≥ 75 into 8 ohm at <1 kHz
11. Power supply : The amplifier shall work on
230V $\pm 10\%$, 48-52 Hz single
phase AC supply
12. Level difference between : Equal to or less than 0.5 dB
the channels

13. Phase difference between the channels $\leq \pm 10^0$, 20 Hz to 20 kHz
14. Inter-channel X-Talk isolation at 15 kHz : ≥ 75 dB at nominal level

ACCESSORIES

- i) All necessary accessories like power cord and mating connectors shall be supplied along with the units. The standard accessories should be clearly mentioned in the quotation.
- ii) Optional accessories if considered useful/ recommended by the supplier should be quoted separately.

MECHANICAL

The amplifier should be 19" rack mounting type.

8.9 DEDICATED PC :

The applicable model of PC may be quoted for setting various parameters of the receiver including its tuning. It should be pre-loaded with some standard communication software like VT-100. This PC should be compatible with the Analog / Digital SCPC Receivers and also as per the recommendations of the Analog / Digital SCPC Receiver manufacturer. Other specifications are given below :

Pentium-4 processor or latest version, with minimum speed of 1.5 GHz, Min 80GB HDD, Min 512 MB DDR2 SD RAM, CD-RW/DVD Combo Drive (52x32x52x; 16x or better), 32 MB Video RAM, 10/100 Base T NIC Card, Keyboard, Mouse with pad, four nos of USB ports, Serial and parallel ports, Windows X-P Professional or later version. Back up copy of licensed operating system software should also be supplied. The monitor should be LCD/TFT type Flat panel display of 17" or more. PC should be complete with necessary interfaces, connectors etc. PC should be rack mountable

8.10 GENERAL / ENVIRONMENTAL

- | | |
|------------------------|--|
| a) Outdoor Unit | |
| Power supply for LNBC | Digital receiver should be able to supply requisite power supply for LNBC. |
| Operational Wind Speed | Upto 80 kmph |
| Survival Wind Speed | Upto 150 kmph |
| Ambient Temperature | 0°C to + 50°C |
| | (-40°C to +40°C for the Stations listed in Annexure A-2) |
| Relative Humidity | 95% at 40°C |

b) Indoor Unit
(Analog/Digital Receiver)

Ambient Temperature	0 to 40°C
Relative humidity	95% at 40°C.
Power Supply	230V ± 5%, 47-53 Hz.

9 GENERAL REQUIREMENTS :

9.1 The RN terminals comprising of C Band Antenna, C band LNBC, Digital Receivers and Analog Receiver will have to be supplied as complete integrated unit (For Stations under Part A) including interconnection of the sub-systems, supply of accessories and other materials necessary for proper installation, operation, maintenance and trouble free service. Suggestive configuration of the rack and jack strip wiring details are attached as **Annexure E** and **Annexure F** respectively.

9.2 The distance of indoor and out-door units could be around 50-60 M. So provision should be made accordingly. The rate for the RF cable may also be quoted per meter basis so that additional length as per actual requirement may be ordered later. For ranking purposes, an average of 50m length is considered.

9.3 Tenderer are required to provide proper climbing arrangement for repairing/maintaining LNBC and feed mounted on the Antenna.

9.4 The technical bid of the tenderer should contain, apart from the technical compliance statement, all original data sheets of the manufacturer in support of the technical compliance statement. The tenders containing only technical compliance statement without the original data sheet/pamphlets of the equipment offered in full are likely to be rejected.

9.5 A comprehensive schedule of material offered should be attached with the offer in the same format as price bid minus price.

9.6 The tender/offer should include following details :

- (i) Sufficient information should be furnished with the tender to assess full merits/demerits of the offer.
- (ii) Apart from printed technical data/specs of this equipment, Block schematic of the sub-system, including the photograph etc. should be attached with the offer.
- (iii) A complete schedule of equipment, accessories and option etc. should also be appended with the tender.

9.7 List of essential spares giving quantities and cost may also be given alongwith the offer.

9.8 Maintenance support in terms of spare units/components be ensured for atleast 10 years.

9.9 Technical Manuals : The supplier will provide original equipment manuals for installation, operation and maintenance for all the item of the RN Equipments as per details below :-

- ◆ 1 Set for each location
- ◆ 2 Sets for Zonal office
- ◆ 2 sets for Directorate General
- ◆ 1 Set for STI(T)
- ◆ 1 set for R&D

List of Stations where complete C-Band RNT is to be supplied, Installed, Tested and Commissioned:**Details of Equipments to be provided at each of the station:**

S.No	Item
1.	6.1 M Parabolic Antenna with feed and accessories (1set)
2.	a) C Band LNBC(2 Nos) b) low loss cable of 50 length (2 Nos) c) 1 : 4 Power Divider (1 No)
3.	PC (1 No)
4	L band Digital Receiver (2 Nos) (4 Nos for National Channel, Todapur)
5	L band Analog Receiver (1no) (2 Nos for National Channel, Todapur)
6	Wired Rack of 42U with Jack strip and Tag block (1 set)
7	Stereo Monitoring amplifier with speakers (1 set)

List of Stations:

	East Zone
1	AIR, Daltonganj
2.	AIR, Shantiniketan
3.	AIR, Soro
	North East Zone
4.	AIR, Saiha
5.	AIR, Tuensang
6.	AIR, Mon
7.	AIR, Williamnagar
8.	AIR, Nongstoin
	South Zone
9.	AIR, Nizamabad
10.	AIR, Manjeri
11.	AIR, Dharamapuri
12.	AIR, Mangalore
13.	AIR, Macherla
14.	AIR Mysore
	North Zone
15.	AIR, Mathura
16.	National Channel, Todapur, New Delhi
17.	AIR, Kargil
18.	AIR, Churu
19.	AIR, Faizabad
20.	AIR, Obra
	West Zone
21	AIR, Saraipalli
22	AIR, Rajgarh
23.	AIR, Himatnagar
24.	AIR, Mandla

List of Stations where Partial C-Band RNT is to be supplied and installed:**Details of Equipment to be supplied at each of the station:**

(The installation of these equipment at Stations and their integration with the existing equipment shall be carried out by the Supplier)

S.No	Item
1.	6.1 M Parabolic Antenna with feed and accessories along with De-Icing system (1 set)
2.	a) C Band LNBC (2 Nos) b) low loss cable of 50 length(2 Nos) c) 1 : 4 Power Divider (1 No)
3.	PC (1 No)

List of Stations:

North Zone	
1	AIR, Rajouri
2	AIR, Naushera
3	AIR, Kupwara
4	AIR, Khalsi
5	AIR, Diskit
6	AIR, Nyoma
7	AIR, Drass
8	AIR, Padum
9	AIR, Tiessurru
10	HPT Kargil
11.	AIR Bhadarwah

List of Stations where Partial C-Band RNT is only to be supplied:**Details of Equipment to be supplied at each of the station:**

Sl. No	Item
1.	L band Digital Receiver (4 Nos)
2.	L band Analog Receiver (2 Nos)
3.	a) C Band LNBC (2 Nos) b) low loss cable of 50 length (2Nos) c) 1 : 4 Power Divider (1 No)
4.	P.C.(1 No)

List of Stations:

North Zone	
1	HPT, AIR, Aligarh
2	AIR, Gorakhpur
South Zone	
3	SPT, AIR, Bangalore
4	AIR, Allepey
5	AIR, Dharwar
West Zone	
6	SPT, AIR, Nagpur
7	SPT, AIR, Rajkot
North East Zone	
8	AIR, Guwahati
East Zone	
9	AIR, Cuttuck

AIR - RN SYSTEM PARAMETERS

Type of Receive Terminals

C-Band	Size	6.1 M
	G/T	24 dB/°K
	Polarisation	Linear H/V

System Characteristics :

Mode	SCPC
RN Channel Band-Width	200 KHz(Analog) 350 KHz (Digital 256 kbps)

Analog System :

Modulation/Demodulation	Companded FM
Base-Band	15 KHz
Compression	2 : 1
Pre/De-emphasis	75 μ Sec.
Peak deviation	\pm 75 KHz at +9 dBm

Digital System :

Modulation	QPSK
FEC	1/2, Convolutional coding and sequential/Viterbi decoding
Base-Band Compression	ISO MPEG - I layer-II Selectable Rates
Base-Band Modes	20 Hz - 20 KHz Stereo, Joint Stereo, Mono, Voice/Data Channel

INSAT SYSTEM DETAILS

Satellite Locations : Different locations from 55°E to 105°E
(Presently 55°, 74°, 83°, 93.5°)

CXC-Band Transponder	5925 – 6425
Uplink Freq. Band	3700 – 4200
Downlink Freq, Band	38 dBw
Sat. EIRP	-85 dBw/ m ²
S.f.d.	
Polarisation	Linear H/V or circular
Uplink	Linear H/V or circular
Downlink	

DRAFT ACCEPTANCE TEST PROCEDURE**INTRODUCTION**

New C-band Digital and Analog RN terminal to be installed at various AIR stations are to be tested to ascertain the performance of these terminals before final acceptance. These C-band terminals have to be tested and supplied by the company.

SCOPE

This document describes the test procedure for link level measurement of C Band RN terminals. Details of the operating parameters and setting at which measurements are to be carried out are given in subsequent sections.

OBJECTIVE OF LINK LEVEL MEASUREMENTS

Digital & Analog C-Band transmit (uplink) is already operational at CES Delhi. The operating parameters of transmit system are enclosed as **Annexure-C1**. The down link testing is to be carried out based on these parameters.

Detail measurements of the downlink receive system would consist of following:

- RF measurements
- Baseband measurements
- To test the received audio qualitatively
- Endurance test

These measurements would be carried out in real time coordination with CES, Delhi for the C-band Analog and Digital transmit system .

TEST EQUIPMENTS

The test equipment are required to be arranged by the supplier.

- (a) Spectrum Analyzer
- (b) Audio signal generator
- (c) Audio analyzer

SET-UP & PRE-CHECKING:

Following points may be checked up before the measurements are carried out:

- (i) Check for the items supplied, serial no., quantity as per order including manuals etc.
- (ii) Individual operational controls of units, settings, levels should be set up as per details given in the manual and subsequent sections. The functioning of controls and displays may be checked.
- (iii) The receive system, after installation, is to be lined up for satisfactory downlink audio reception and functioning of the system.
- (iv) Test and measuring equipment may be checked up and be kept switched on at least 15-20 minutes to allow them to stabilise before measurement.
- (v) Arrangements for communication with CES Delhi for real time coordination and testing be made.

LINE UP & TESTING

ANTENNA LINE UP AND TESTS: The receive antenna is to be optimised for best down link reception using either beacon signal or Delhi carrier. Optimisation for all i.e. Azimuth, elevation and polarisation be done for best results. Readings of beacon signal be noted and if possible beacon reception print out be taken.

DIGITAL RECEIVERS :

The measurements detailed below will have to be done in real time coordination with CES, BH, Delhi.

The transmit side parameters will be set by CES Delhi. The transmission signal parameters will be communicated from Delhi and the receiving station will note down the readings on receive side.

I. RF MEASUREMENTS

Following measurements are to be taken:

Received Signal level:

Check the received signal level of pure carrier on spectrum analyser and note down the reading.

Eb/No, C/No, BER measurement:

Vary modulator output level in steps of 1 dbm and note down the C/No at the receive end on spectrum analyser. The corresponding Eb/No and BER values may be noted down by giving the commands EB and RB respectively to the Receiver through Dumb Terminal. The threshold at which the receiver starts to loose Audio synchronisation is to be noted.

Serial No:
(Data rate 256 Kbps, Coding-Vit 1/2)

S.No.	MODULATOR OUTPUT (dbm)	C/No (dB-Hz)	Eb/No (dB-Hz)	BER	Remarks

II. BASE BAND MEASUREMENTS:

Linearity:

Vary the input to the Encoder from -8 dBm to +8 dBm in steps and note the output on the analyser, which is connected to the receiver. Carry out measurements for both channels and note down the results.

Linearity: (Test Signal 1 KHz)

	Input Level	
	Left Channel	Right Channel
(a) -8 dbm		
(b) 0 dbm		
(c) +8 dbm		

Frequency Response:

Feed a 0 dbm reference signal at 1 KHz to the Encoder. Vary the frequency of the signal from 20 Hz to 20 KHz in steps and note down the output level of the signal at the receive end.

Frequency Response (0 dbm, 1 KHz reference)

S.No	Frequency (Hz)	Left Channel	Right Channel	Remarks

SNR, THD and Cross Talk:

Feed a +8 dBm, 1KHz test signal at the Encoder and measure output level, THD, SNR and cross talk in respect of both channels.

Input: 1 KHz, +8 dBm

S.No.	Channel	Output (dBm)	THD (%)	SNR (dB)	Cross Talk (dB)	Remarks
	Left					
	Right					

III Subjective Listening:

Listen to the received programme for satisfactory audio quality. Subjective Listening comments may be given

ANALOG RECEIVERS

RF MEASUREMENTS:

1) Received Signal level:

Check the received signal level of pure carrier on spectrum analyzer and note down the reading.

Serial No:

RF Level :

BASE BAND MEASUREMENTS:

1. Linearity:

Feed a 1KHz signal to the input of Analog Modulator and vary the input in steps from -10 dbm to +10 dbm, and note down the output level. Carry out the measurements for both channels.

S.No	INPUT (dBm)	OUTPUT (dBm)	
		CH1	CH2
	+ 10.0		
	0		
	- 10.0		

2. Frequency Response:

Feed -20 dBm reference signal at the input of Analog Modulator. Vary the frequency of the signal from 30 Hz to 12.5 KHz in steps and note down the response with respect to 1 KHz signal.

S.No	Frequency (Hz)	Response w.r.t. 1 KHz	
		CH1	CH2

3. THD, SNR & Cross Talk Measurements:

Feed 0 dBm reference signal at the input of Analog Modulator. Note down the output level of the signal, distortion and SNR at the receive end for both channel 1 and channel 2 .

S.No.	Channel	O/P (dBm)	THD %	SNR (dB)	Cross Talk (dB)	Remarks
	I					
	II					

4. Subjective Listening:

Listen to the received programme for satisfactory audio quality. Subjective Listening comments may be given.

5. Endurance Test

In addition to the above tests, the system is to be kept "ON" for 48 hours and any degradation/ malfunctioning of the RN Terminals, is to be noted. Variation in signal level, heating of components, particularly the working of LNBC, drift in L-Band output freq. of LNBC etc. are to be checked and noted.

TRANSMISSION PARAMETERS FOR DIGITAL C-BAND SYSTEM

A. INSAT System Details and Uplinking Parameters

Satellite	:	INSAT-3C
Transponder	:	C-11
Uplink Centre freq.	:	6350 MHz
Downlink Centre freq.	:	4125 MHz
Uplink Polarisation	:	Linear Vertical
Downlink Polarisation	:	Linear Horizontal
Uplink	:	From CES DELHI
Downlink	:	Testing Site

Frequency for link level testing

	Uplink	Downlink
Digital Carrier	*	*
Analog Carrier	*	*

* Freq. shall be intimated at the time of testing.

B. ANALOG CHAIN PARAMETERS

Modulation	:	FM
Mode	:	Mono

C. DIGITAL CHAIN PARAMETERS

Modulation	:	QPSK
FEC	:	1/2, Seq./Viterbi decoding
Baseband	:	20 Hz-20KHz
Baseband compression	:	ISO MPEG-I, Layer II MUSICAM
Mode	:	Dual Mono
Bit rate	:	256 kbps

D. PRESENT CARRIERS OPERATION IN C-BAND

	<u>Uplink freq</u> (MHz)	<u>Downlink freq.</u> (MHz)	<u>IF</u> (MHz)
Four Delhi Analog Carriers:-			
DLC1 :	6341.000	4116.000	04--74.00
DLC2 :	6341.400	4116.400	04--73.60
DLC3 :	6341.800	4116.800	04--73.20
DLC4 :	6342.200	4117.200	04--72.80
DLC5(digital)	6342.600	4117.600	
DLC6(digital)	6343.000	4118.000	
DLC7(digital)	6343.400	4118.400	
DLC8(digital)	6343.800	4118.800	

Two VB, Borivalli Carriers:-

VB Analog :	6354.200	4129.200	04—60.80
VB Digital :	6353.800	4128.800	---

BLOCK DIAGRAM FOR C BAND DIGITAL & ANALOG RN TERMINAL

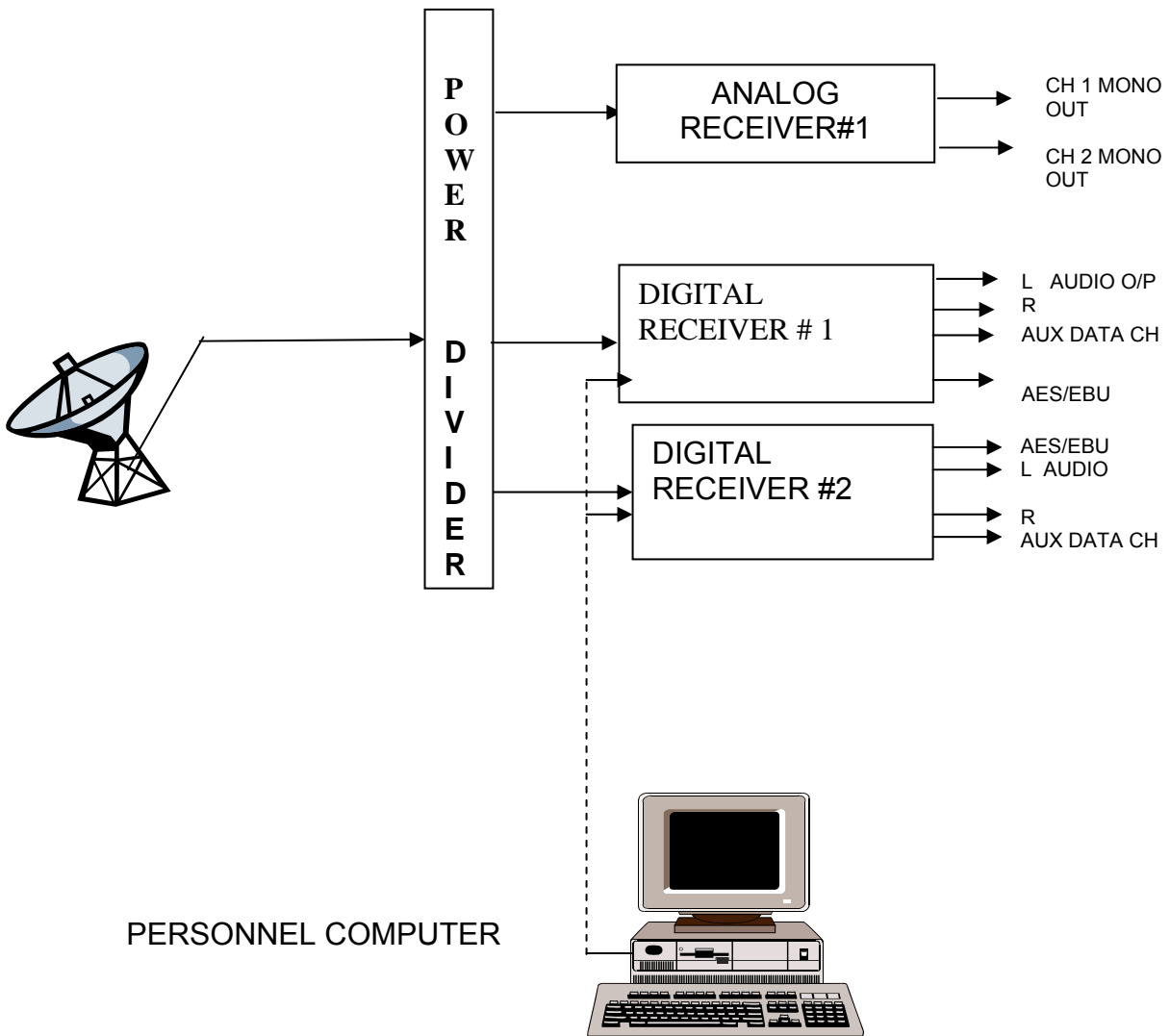

SUGGESTIVE RACK CONFIGURATION FOR RN TERMINAL
 TOTAL SIZE OF THE RACK = 42 U

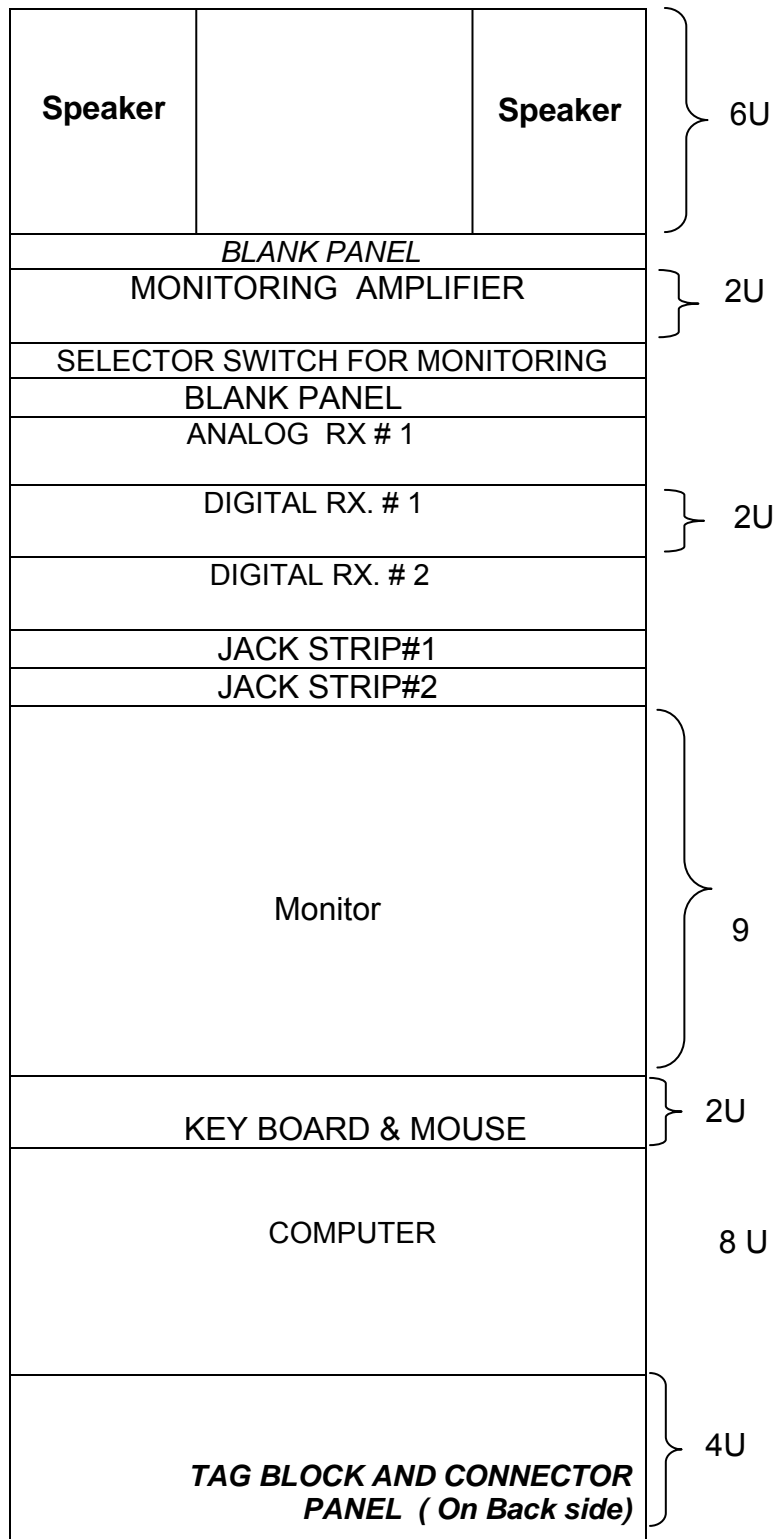

ANNEXURE-F

